

PREMIUM PROGRAMME

2017

CUTTING

GRINDING

SANDING

CLEANING

POLISHING

FINISHING



START WITH DRONCO.



FINISH WITH OSBORN.



STARTING AT PDF-PAGE 3



START WITH DRONCO.



STARTING AT PDF-PAGE 136



FINISH WITH OSBORN.

SURFACE TREATMENT. COMPLETE. FROM A SINGLE SOURCE.

Dear Customers,

You can turn it and flip it the way you want ... On around 300 pages of our new combined catalogue, you will find the whole range of products for mechanical surface treatment. Regardless of whether you would like to cut, grind and sand or clean, brush and polish - we are there for you.

We, the companies of DRONCO and Osborn. With over 180 years of mutual experience in surface finishing, we have a solution for almost all of your application requirements. We are also pleased to assist you finding the right product.

In the DRONCO section, you will find our product portfolio of cutting discs, grinding discs, flap discs, polishing flap discs, diamond cutting discs and diamond tools, bonded abrasives, ceramic abrasives and technical brushes.

If you are a customer of DRONCO today, we invite you to get to know the other side: Simply flip the catalogue and discover the Osborn product world of machine brushes, hand brushes, polishing and satin finishing tools, brush technology for industrial applications and special solutions.

The good thing is, you do not need another customer number or another contact person. Just talk to your well-known contact and you can order both DRONCO and Osborn products with your existing customer number. Try it out! We look forward to working with you!



➔ Find the Osborn products starting at PDF-page 136.

Content

Metal cutting discs 18



Stone cutting discs 44



Grinding discs 52



Flap discs 62



Cleaning- and polishing tools 75



Diamond cutting discs 84



Diamond tools 110



Flexible and semi-flexible abrasives 118



Vitrified bonded abrasives 131



Technical brushes 133



Index 134

WITH DRONCO INTO POLE POSITION

DRONCO is one of the biggest and most innovative manufacturers of abrasives in Europe.



WELCOME AT DRONCO

DRONCO is one of the biggest and most innovative manufacturers of abrasives in Europe. Our company is part of the Jason Industries, Inc. to which Osborn belongs as well.

With its production plants in 14 countries and around 2,000 employees worldwide, the Jason Industries, Inc. serves markets in 120 countries with quality tools for surface treatment.

DRONCO currently owns the most advanced manufacturing technology for cutting and grinding discs in Europe. We are producing approximately 200,000 cutting and grinding discs and 40,000 flap discs every day in our production plant in Wunsiedel (Bavaria).

Our range of cutting and grinding discs, diamond tools, ceramic abrasives, abrasive paper sheets and technical brushes for professional craftsmen as well as demanding do-it-yourselfers is produced in globally recognized high quality.



INNOVATION DRIVER

DRONCO is among the most innovative and agile manufacturers in the abrasive sector.

Our own R+D department is working in modern laboratories on future-oriented technologies for abrasive tools. Existing products are continuously improved as well.

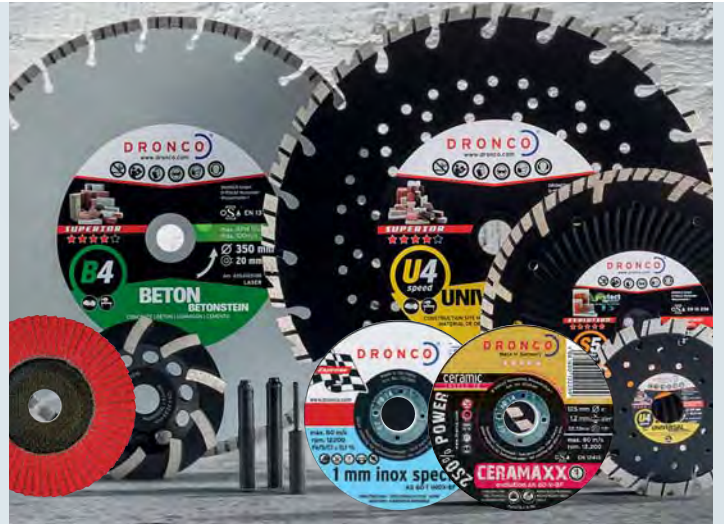

CUSTOMER-ORIENTED

For us, client orientation is of absolute importance. DRONCO was awarded 1st place as "Commercial Partner of the Specialized Trade" multiple times throughout the last years.

Evaluation criteria were: trade loyalty, innovative strength, marketing and sales support as well as the handling of complaints.



**INNOVATIVE. CUSTOMER-ORIENTED.
RELIABLE.**

FORWARD-THINKING PRODUCTION TECHNOLOGY

DRONCO sets standards for the future already today.

“Progress - Made in Germany” is for us the perfect interaction of indicative technology and sustainable research and development.



HIGH-TECH & SUSTAINABILITY

Intelligent manufacturing technology of the latest generation, highly qualified employees and the unique DRONCO Production-System allows a flexible, rational and exact production, according to the highest quality standards here in Germany.

DRONCO has developed a pressing technology that ranks worldwide among the most advanced systems. With an almost complete renewal of our machinery, we are one step closer to attain our ambitious target, to take over the technology leadership in our branch.

With an investment of six million Euros, we further extended and modernized our production site in Wunsiedel until mid of 2016.

Now DRONCO has the most advanced presses for cutting and grinding discs in Europe. This technology helps us to ensure the high quality of our products and to reduce emissions at the same time, making a sustainable contribution to preserving the environment. We will continue to do everything to strengthen our competitive position for the future.



RESEARCH & DEVELOPMENT

Our R+D team is working in modern laboratories on future oriented technologies for abrasive tools, resulting in product innovations and a continuous improvement of existing products with regard to cutting ability, lifetime, speed and precision.

The results are diverse pending patents and the market launch of several world innovations in the field of groundbreaking cutting and grinding technologies.



QUALITY & PERFORMANCE TESTING

In order to determine the performance of our products, we are testing with a state-of-the-art industrial robot. The robot delivers precise results and allows our quality assurance to carry out various tests under the exact same conditions.

In addition to a pure performance determination, the robot also helps us to ensure a consistently high standard by means of permanent checking. Complex processes can be simulated easily; realistic simulations are used especially for product development and the permanent optimization of existing tools.



SUSTAINABLE RESEARCH + DEVELOPMENT

Here at DRONCO, the R+D department is of great importance. Newly built laboratories with state-of-the-art technical equipment meet all requirements for testing, chemical and analytical procedures and applications.

OUR PRODUCTS SAFETY FIRST

Work safety is an important task. This is why DRONCO treats this issue in a particularly responsible manner. Users and dealers are on the safe side with us.



HIGHEST SAFETY STANDARDS

Cutting and grinding require a very high circumferential speed of the rotating tool in many areas of application. Therefore, our products are specifically designed to safely withstand the extreme mechanical and thermal stresses and strains. All DRONCO products correspond to current standards.

Continuous tests guarantee the observance of the highest safety standards. For this purpose, a further, state-of-the-art test system for side load tests was put into operation.

Complex measures for product testing are carried out on the new system. First, cutting discs are subjected to a pre-defined lateral load and then subjected to a fall hammer test. The test results are automatically recorded and evaluated.

Our quality management system ensures that we meet the high demands of a modern, worldwide acting industrial enterprise on each level. Certification in accordance to DIN EN ISO 9001:2008 is therefore just as natural as our membership with oSa.



CERTIFIED SAFETY

We manufacture according to the strictest directives worldwide and monitor the safety and quality of our products according to the latest standards and regulations:

EN 12413

European safety standard for cutting and grinding discs

EN 13743

European safety standard for bonded abrasives

EN 13236

European safety standard for diamond tools

E DIN ISO 13942, 603-16, 6103, 15635

Dimensions, tolerances and unbalance

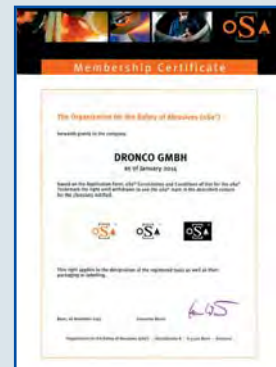

DRONCO IS MEMBER OF OSA



**MANUFACTURING & QUALITY ASSURANCE
ACCORDING TO STRICT REGULATIONS**

MODERN LOGISTICS

DRONCO products are used in more than 100 countries in the world.
Modern logistics ensures complete and timely deliveries to our customers.



LOGISTICS CENTER WUNSIEDEL

Our high standards to manufacturing continue also at the field of logistics. Our new logistics center, close-by to the production, has been opened in 2008 and offers

4,000 sqm storage space

950 sqm office space

2,500 sqm traffic area

1,400 sqm space for packing

as well as a high rack storage area with space for

9,200 pallets and

4,800 ground level shelves.

Automated warehousing ensures complete and timely delivery of the products - to the satisfaction of our customers. Intelligent software enables transparent logistics.



DRONCO CODE OF CONDUCT

The legal framework has become very complex, even for traditional companies and the globalized economic relations have implied new requirements.

The integration of a code of conduct in the company organization ensures a systematical control and documentation of the compliance. DRONCO is committed to prevent bribery and to comply with ethical principles towards customers, competitors and business partners.

Our code of conduct comprises regulations against corruption, forced and child's work and defines social and ethical standards to be applied. It is valid not only for all employees but also for our suppliers worldwide. Dronco takes part of the annual company statements of the BME. Our compliance-management is training the employees, controls the compliance and is the contact-person for all demands and questions.

More information about the BME can be found on the web: www.bme.de

COMPLIANCE MANAGEMENT

DRONCO has joined the Code of Conduct of the BME and has implemented a code of conduct into the company organization.



SOLUTIONS FOR A STRONG PRESENTATION

DRONCO – a strong brand. Our extensive support promotes your turnover!

EXCELLENT SALES PROMOTION

Our sales promotion is coordinated constantly to the needs of the trade. Attention-strong sales assistance at the POS and the newly arranged product shelf is lastingly supporting your sales. Dealer promotion activities taking place several times during the year are providing additional turnover.

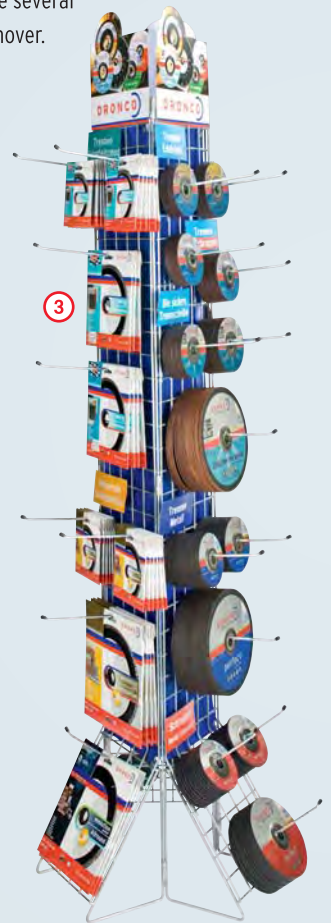

- 1** DRONCO Wire Presentation for tins:
Our bestseller: The 1mm special disc for steel and stainless steel in a 10-pack tin. Simply hang in the support between the modules or in a rear panel (suitable adaptor supplied) and watch your sales take off!
Dimensions: 15 x 135 x 16 cm

- 2** DRONCO Sales Display:
Diamond blades F5 cera speed
Dimensions (BxHxT): 16x36x23 cm

- 3** DRONCO Triangle Display:
Can be stocked individually with new or standard products.
Dimensions: 28 x 175 cm

- 4** DRONCO Sales Display for Polishing Flap Discs:
Many customers say "grinding" but really mean "derusting and polishing". Show them that you are the expert!
Dimensions: 42 x 34 x 28 cm

- 5** The DRONCO Classic:
Stainless Steel Tin Promotion Display
The sales hit at every counter.
Dimensions (BxHxT): 20x31x20 cm

INNOVATIVE PRODUCTS

As a DRONCO dealer you will profit from our extensive manufacturer's authority. With perfect product quality, highest safety standards and constant innovation we are setting standards on the market.

BEING IN THE MEDIA

DRONCO regularly places colour advertisements in technical and specialized magazines, and provides PR articles in order to sensitize the end user on the premium brand - excellent measures for an excellent product range!

PROMOTION VAN

We support the specialized trade with promotion vans, which are constantly in use on in-house fairs, on open days, or locally together with the specialized trade and the end user.

TRAINING OF YOUR SALES STAFF

Confidence in the sales talk with the end user generates a rise in turnover. Your sales personnel will receive professional knowledge in an entertaining and interesting training course which contains theory and practice.



ATTRACTIVE DESIGN

We present ourselves on the market visually clear and well planned. This includes packaging as well as contents. An effectively arranged colour guideline system leads easily and surely through the product assortment.



PRODUCT PROMOTION

ATTENTION GUARANTEED

Professionals set the standard – also with the presentation at the point of sale.



EXCELLENT SALES PROMOTION – ADDITIONAL TURNOVER

Our elaborate concept provides for a premium sales promotion and increases your image as a top-quality supplier. Intelligent goods presentation and eye-catching sales assistance is lastingly supporting your sales. The DRONCO product shelf offers you an abundance of options to present your premium assortment of goods in a clear and attractive way.

EXCLUSIVE SERVICE FOR OUR DEALERS

The labeling of the product shelves as well as the supply lists are exactly adjusted to your demands. Colour coding systems facilitate orientation.

MODULAR ACCESSORIES



Colour coding systems facilitate orientation



Lockable hooks

Modular display assembly in different dimensions:
Individual modules that fit into common systems
with widths of 1.0 and 1.25 m



Diamond show case with
Plexiglass door



The complete DRONCO product range is presented progressively and dynamically. 3x1.25 m

3 PRODUCT LINES FOR EVERY APPLICATION

Three quality lines according to the good-better-best principle: From the solid craftsman's quality to the high-performance tool for the most intensive use.

GOOD

BETTER

BEST

PERFECT

Universal products in solid and proven craftsman quality. Our bestseller at a favourable price.

SPECIAL / SUPERIOR

The special program for craft and industry. Effective, long lasting, economical!

EVOLUTION

The universal high-end line in top quality for highest demands.

METAL CUTTING DISCS



STONE CUTTING DISCS



GRINDING DISCS



FLAP DISCS



DIAMOND CUTTING DISCS



ABRASIVES



ADDITIONAL BENEFIT

Beside the specific cutting and grinding performance many of our products have an additional benefit for the user.

EXPRESS - THIN, PRECISE, FAST

- considerably faster
- exact cutting
- no chipping on the edges
- effortless performance



PROTECT - PRESERVE YOUR HEALTH

- less noise
- less vibration
- less dust



FREECUT - PROBABLY THE WORLD'S SAFEST CUTTING DISC

- no pinching in the cut
- reduced danger of 'kick-back' effect (setback of the angle grinder)
- no lateral friction



CUT+GRIND - THE CLEVER COMBINATION OF TWO FUNCTIONS

- cutting and grinding with one disc
- no change of disc necessary
- fast cutting with high removal rate

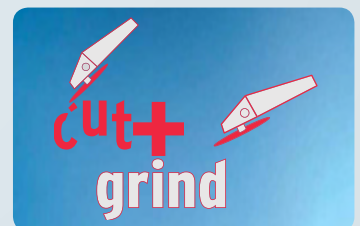

BATTERY FRIENDLY - FOR CORDLESS POWERED ANGLE GRINDERS

- flexible in usage
- easy to handle
- precise working



Some general information

The following information gives you the best possible overview about the features of our products.

1 Description

Compiled for cutting discs as follows:

A/AS – aluminium oxide is the abrasive grain for cutting metal.

AZ – zirconium corundum is the abrasive grain for better life time and cutting efficiency.

46 – indicates the grit size. The higher the number, the finer the grit. E.g.: 24 rough | 30 medium | 36 fine ...

R – the second letter indicates the hardness of the disc. The further into the alphabet, the harder the disc.

BF – resin bonded, fibre- reinforced

2 Product lines

perfect | evolution | special

Explanation see next page.

3 Blue background

Is the colour coding for metal cutting discs.

4 Safety standards

Our products comply with the highest safety standards and regulations:

EN 12413 - cutting and grinding wheels

ISO 9001 - organisation for the safety of abrasives.

5 Measurements

Consist of (diameter of the disc)

x (thickness of the disc)

x (bore size).

Measurements given in mm and inch.

6 Expiry date

This quality cutting disc can be used without any restrictions until the indicated date.

(V month/year)

7 Max. rpm.

Indicates the permitted maximum speed.

8 FE/S/Cl ≤ 0,1%

Free from iron, sulphur and chlorine.

Special disc for cutting stainless steel.

9 Safety information

Security information: For your own safety.

Please follow!

10 Red bar

Indicates 80 m/s as permitted peripheral speed.

Green bar

Indicates 100 m/s as permitted peripheral speed.

11 Made in Germany

Stands for proven quality - most of our products are manufactured and tested in Germany.

12 www.dronco.com

24 hr service on our website - we are always there when you need us!

9 Safety information



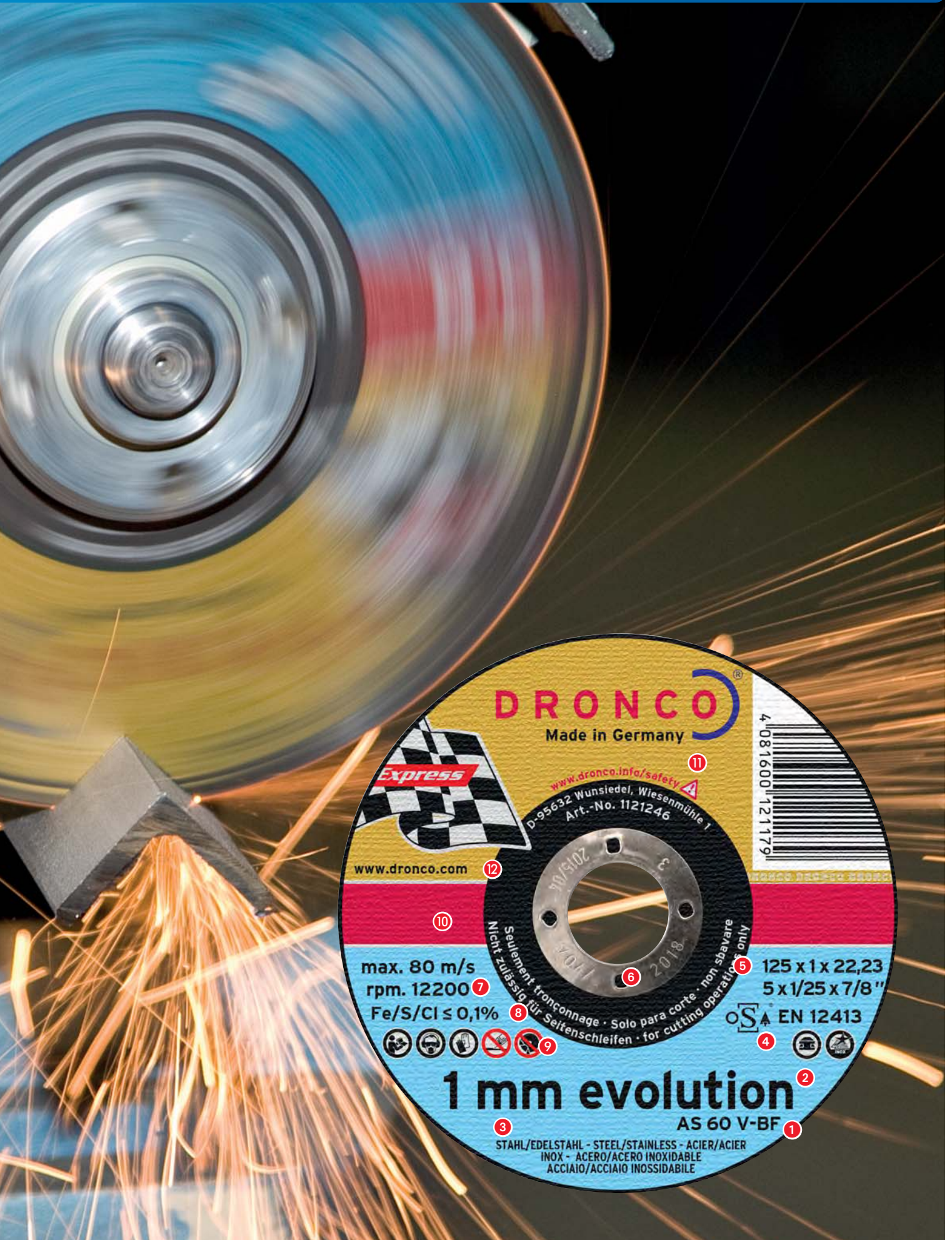

METAL CUTTING DISCS



DRONCO
Made in Germany

Express

www.dronco.info/safety 
D-95632 Wunsiedel, Wiesenmühle 1
Art.-No. 1121246

www.dronco.com 

4 081600 121179

max. 80 m/s
rpm. 12200

Fe/S/Cl ≤ 0,1%

125 x 1 x 22,23
5 x 1/25 x 7/8"

EN 12413

1 mm evolution

AS 60 V-BF

STAHL/EDELSTAHL - STEEL/STAINLESS - ACIER/ACIER
INOX - ACERO/ACERO INOXIDABLE
ACCIAIO/ACCIAIO INOSSIDABILE

Seulement tronçonnage · Solo para corte · non sbavare
Nicht zulässig für Seitenschleifen · for cutting operation only

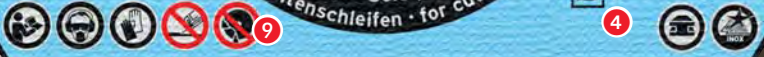

Product lines

For craftsmen or industrial use - three precisely co-ordinated product lines offer the right cutting disc for every user and every application. All discs comply with the relevant regulations, have a high specific cutting capacity and guarantee a maximum of safety.



perfect line

The best-seller with an excellent price/performance ratio. It has proven itself a million times in the hands of craftsmen and semi-professionals.

- manufactured according to EN 12413
- complies to oSa regulations



special line

The special line for craftsmen and industrial applications. Due to the fact that different materials impose different demands, DRONCO produces discs especially matching the respective material. Special types of corundum and bonds are combined to suit the task in hand. This optimises performance, extends service life, increases efficiency and reduces cutting time.

- manufactured according to EN 12413
- complies to oSa regulations



evolution line

Designed by experts and made of top quality raw materials, these all-round cutting discs combine outstanding service life with high cutting speed.

- manufactured according to EN 12413
- complies to oSa regulations



Application chart metal cutting discs															
	Page	unalloyed and alloyed construction steel	very solid construction steel	tool steel	high alloy special steel	angular steel profiles	angular stainless steel profiles	rails	cast	aluminium alloy	copper	brass bronze	tiles	marble	schist
FREE HAND CUTTING DISCS STAINLESS STEEL															
AS 60 W EVOLUTION EXPRESS 0,8	22	●	●	●	●	●●	●●		○	●	●	●			
A 60 R PERFECT EXPRESS 1,0	23	●●	●	●	●	●	●		○	○	○	○			
AS 60 T INOX SPECIAL 1,0	23	●	●	●	●●	●●	●●		○	●●	●●	●●			
AS 60 V EVOLUTION EXPRESS 1,0	25	●●	●●	●●	●●	●●	●●		●	●	●	●			
AS 60 W HT EVOLUTION JUBILEE 1,0	26	●●	●●	●●	●●	●●	●●		●	●	●	●			
A 46 R PERFECT EXPRESS 1,6	26	●●	●	●	●	●	●		○	○	○	○			
AS 46 T INOX SPECIAL 1,6	27	●	●	●	●●	●●	●●		○	○	○	○			
AS 46 V EVOLUTION EXPRESS 1,6	28	●●	●●	●●	●●	●●	●●		●	●	●	●			
AK 60 V EVOLUTION CERAMAXX	30	●●	●●	●●	●●	●●	●●		●●	●	●	●			
AK 46 V EVOLUTION CERAMAXX	30	●●	●●	●●	●●	●●	●●		●●	●	●	●			
ACS 46 / ACS 60 T MULTI	31	●	●	○	●	●●	●●		●●	●●	●●	●●	●●	●●	●
AS 46 / AS 60 T INOX FREECUT	32	●	●	●	●●	●●	●●		●	●	●	●			
AS 46 / AS 30 T INOX CUT+GRIND	33	●	●	●	●●	●	●●		●●	○	○	○			
AS 30 S INOX SPECIAL, 2,5	34	●	●	●	●●	●	●●	●	●●	●	●	●			
AS 30 T INOX SPECIAL, 2,2	34	●	●	●	●●	●	●●	●	●●	●	●	●			
FREE HAND CUTTING DISCS STEEL															
A 24 R PERFECT, 3,0	35	●●	●	●	○	●	○		●	●	●	●			
AS 30 S SPECIAL, 3,0	36	●●	●●	●●	○	●	○		●●	●	●	●			
AS 30 T SPECIAL, 2,0	37	●●	●●	●●	○	●●	○		●	●	●	●			
AS 30 S HT EVOLUTION, 3,0	37	●●	●●	●●	○	●	○		●	●	●●	●			
AS 30 V EVOLUTION, 3,0	38	●●	●●	●●	○	●●	○		●	●	●	●			
AS 36 V EVOLUTION, 2,2	38	●●	●●	●●	○	●●	○		●	●	●	●			
FREE HAND CUTTING DISCS ALUMINIUM															
CS 60 ALU SPECIAL, 1,2	39									●●	●●	●●			
CS 46 ALU SPECIAL, 1,6	39									●●	●●	●●			
FREE HAND CUTTING DISCS RAIL SECTIONS															
AS 24 R BAHN SPECIAL	40	●	●	●	○	○	○	●●	○	○	○	○			
MINI CUTTING DISCS															
AS 46 T MINI SPECIAL	41	●	●	●	○	●●	○		○	○	○	○			
CUTTING DISCS FOR STATIONARY MACHINES / CHOP-SAWS															
A 30 S PERFECT	42	●	●	●	○	●	○		●	●	●	●			
AS 30 S SPECIAL	42	●●	●●	●●	○	●	○		●●	●	●	●			
AS 36 T SPECIAL / CHOP SAW	43	●●	●●	●	○	●	○		●	●	●	●			
AS 36 S INOX SPECIAL / CHOP SAW	43	●	●●	●●	●	●	●●		●●	●	●	●			



Professional application

Top product: extremely fast cutting, outstanding service life, minimum effort



Demanding application

Very good cutting performance, high service life



Standard application

Good cutting performance, good service life

You can get DRONCO metal cutting discs in different performance classes - from a standard product for occasional use up to the high-end product for professional applications.

Free hand cutting discs stainless steel/steel 0,8 mm

AS 60 W 0,8 mm

evolution

Free hand

★★★★



The extra fine cutting disc Evolution AS 60 W with a thickness of 0.8 mm is the right choice for cutting thin-walled profiles and pipes, thin sheet and ropes. The extra smooth cutting disc is characterised by its fast and smooth cutting with low contact pressure.

Extra fine | Extremely fast

It's not only the outstanding cutting speed that is extra fine, but also the low-burr cut with limited sparking as well as the excellent service life thanks to the Lifetime Plus seal.

For thin sheets, steel ropes, thin-walled profiles and pipes made of stainless steel and non-ferrous metals, as well as composite materials (glass-reinforced plastics)



The AS 60 W is supplied extra fine and extra fresh in Lifetime Plus Tins containing 25 or 10 pieces.

Lifetime-Plus

- over 30% * more service life (number of cuts)
- stops the natural ageing process of synthetic resin-bonded discs
- keeps cutting discs fresh until the pack is opened for the first time

DIMENSION MM	DIMENSION INCH	SPEED R.P.M.	CONTENT PC.	SHAPE	ITEM CODE	BAR CODE 4081600
115 x 0,8 x 22,23	4 1/2 x 0,030 x 7/8	13280	1 TIN à 25		6900842100	701630
125 x 0,8 x 22,23	5 x 0,030 x 7/8	12200	1 TIN à 25		6900843100	701647
115 x 0,8 x 22,23	4 1/2 x 0,030 x 7/8	13280	1 TIN à 10		6900840100	701616
125 x 0,8 x 22,23	5 x 0,030 x 7/8	12200	1 TIN à 10		6900841100	701623
Also available 25 pcs. in shrunk plastic foil						
115 x 0,8 x 22,23	4 1/2 x 0,030 x 7/8	13280	25		1111000100	110302
125 x 0,8 x 22,23	5 x 0,030 x 7/8	12200	25		1121000100	120301

* compared to a standard 1mm cutting disc, stored for 6 weeks and subject to a natural ageing process which results in reduction of service life.



Free hand cutting discs stainless steel/steel 1,0 mm

A 60 R 1 mm perfect Free hand ★★☆☆



The economic alternative for thin steel cutting discs. Good cutting ability with a good lifetime, manufactured in 1 mm.

Thin-walled profiles and sheet metals in structural and container work. Is often used in car-body building. Suitable for stainless steel as well.

DIMENSION MM	DIMENSION INCH	SPEED R.P.M.	CONTENT PC.	SHAPE	ITEM CODE	BAR CODE 4081600
115 x 1,0 x 22,23	4 1/2 x 1/25 x 7/8	13280	25		1110240100	110012
125 x 1,0 x 22,23	5 x 1/25 x 7/8	12200	25		1120240100	120011
115 x 1 x 22,23	4 1/2 x 1/25 x 7/8	13280	1 Tin à 10		6900987100	701319
125 x 1 x 22,23	5 x 1/25 x 7/8	13280	1 Tin à 10		6900988100	701326

AS 60 T INOX 1 mm special Free hand ★★☆☆



This very thin disc (1.0 mm) enables you to achieve a uniquely clean cut in the shortest possible time while using a minimum of force. Precise to the millimetre, vibration-free cutting, no thermal bluing and no burring (precluding the need for subsequent machining).

Thin sheet metal (of the type used in car bodies, tank farms and the tank construction sector), steel cable, thin-walled profile sections and pipes made of stainless steel and non-ferrous metals. Composite materials (FRP). High-temperature materials, e.g. repairing turbines.

DIMENSION MM	DIMENSION INCH	SPEED R.P.M.	CONTENT PC.	SHAPE	ITEM CODE	BAR CODE 4081600
100 x 1,0 x 16,0	4 x 1/25 x 5/8	15250	25		1101240100	101072
105 x 1,0 x 16,0	4 x 1/25 x 5/8	14560	25		1101241100	101157
115 x 1,0 x 22,23	4 1/2 x 1/25 x 7/8	13280	25		1111240100	111026
125 x 1,0 x 22,23	5 x 1/25 x 7/8	12200	25		1121240100	121025

POWER PACK TIN



10 cutting discs in the attractive and popular metal box. A big seller for guaranteed increased turnover.

Each box includes 10 metal cutting discs AS 60 INOX 1mm.

115 x 1,0 x 22,23	4 1/2 x 1/25 x 7/8	13280	1 Tin à 10		6900935	701050
125 x 1,0 x 22,23	5 x 1/25 x 7/8	12200	1 Tin à 10		6900945	701067

AS 60 T INOX 1 mm

special

Free hand

★★★★☆

LIFETIME-PLUS TIN



Over 30% more service-life*:

With the new Lifetime-Plus concept, we have given the Power Pack tin an amazing new function. Lifetime-Plus seals in the full performance of the discs and keeps it there until the pack is opened for the first time. So these "fresh from the oven" discs ensure to put all their power onto the machine.

Lifetime-Plus

- over 30% * more service life (number of cuts)
- stops the natural ageing process of synthetic resin-bonded discs
- keeps cutting discs fresh until the pack is opened for the first time

115 x 1,0 x 22,23	4 1/2 x 1/25 x 7/8	13280	1 TIN à 10	=====	6900850100	701203
125 x 1,0 x 22,23	5 x 1/25 x 7/8	12200	1 TIN à 10	=====	6900852100	701227
115 x 1,0 x 22,23	4 1/2 x 1/25 x 7/8	13280	1 TIN à 25	=====	6900870100	701401
125 x 1,0 x 22,23	5 x 1/25 x 7/8	12200	1 TIN à 25	=====	6900871100	701418

* compared to a standard 1mm cutting disc, stored for 6 weeks and subject to a natural ageing process which results in reduction of service life.

Lifetime-Plus

- ▶ over 30%* more service life (number of cuts)
- ▶ stops the natural ageing process of synthetic resin-bonded discs
- ▶ keeps cutting discs fresh until the pack is opened for the first time



Why Lifetime-Plus?

A standard 1mm cutting disc undergoes a natural ageing process during storage due to the absorption of moisture from the air. After just 6 weeks, the tool life can have fallen by an average of approx. 30%.

The ingenious Lifetime-Plus freshness seal stops this process before it even starts. Prepare to be amazed at the outstanding life of cutting discs from a freshly opened Lifetime-Plus pack.



AS 60 V 1 mm

evolution express

Free hand

★★★★



Clearly faster – clearly more precise – clearly better:
Top class 1mm cutting disc in best quality.
For precision cutting accurate to the millimetre and extremely fast cutting with minimum power consumption. No burring, no blue thermal discolouration. Outstanding optimized service life. True performance for your money.

Thin sheet metal, steel ropes, thin-walled profiles and tubes made of stainless steel and non-ferrous metals, composite materials.

- ▶ outstanding service life
- ▶ outstanding cutting speed
- ▶ lowest power consumption
- ▶ precision cutting accurate to the millimetre
- ▶ low-burr or burr-free edges



Top of the class in speed and tool life

With our extra-thin, high-speed discs you will cross the finishing line in record time. Yet at the same time you can work in extreme comfort, with absolute safety and the highest level of precision – because you are using the best discs from the DRONCO racing stable.

DIMENSION MM	DIMENSION INCH	SPEED R.P.M.	CONTENT PC.	SHAPE	ITEM CODE	BAR CODE 4081600
100 x 1,0 x 16,0	4 x 1/25 x 5/8	15250	25	—	1101246100	101126
105 x 1,0 x 16,0	4 x 1/25 x 5/8	14560	25	—	1101247100	101133
115 x 1,0 x 22,23	4 1/2 x 1/25 x 7/8	13280	25	—	1111246100	111125
125 x 1,0 x 22,23	5 x 1/25 x 7/8	12200	25	—	1121246100	121179

POWER-PACK TIN



10 cutting discs in the attractive and popular metal box. A big seller for guaranteed increased turnover.

Each box includes 10 metal cutting discs AS 60 V 1mm.

115 x 1,0 x 22,23	4 1/2 x 1/25 x 7/8	13280	1 TIN à 10	—	6900975	704877
125 x 1,0 x 22,23	5 x 1/25 x 7/8	12200	1 TIN à 10	—	6900985	704884

LIFETIME-PLUS TIN



Over 30% more service life*:
With the new Lifetime-Plus concept, we have given the Power Pack tin an amazing new function. Lifetime-Plus seals in the full performance of the discs and keeps it there until the pack is opened for the first time. So these "fresh from the oven" discs ensure to put all their power onto the machine.

Lifetime-Plus

- over 30% * more service life (number of cuts)
- stops the natural ageing process of synthetic resin-bonded discs
- keeps cutting discs fresh until the pack is opened for the first time

115 x 1,0 x 22,23	4 1/2 x 1/25 x 7/8	13280	1 TIN à 10	—	6900851100	701210
125 x 1,0 x 22,23	5 x 1/25 x 7/8	12200	1 TIN à 10	—	6900853100	701234
115 x 1,0 x 22,23	4 1/2 x 1/25 x 7/8	13280	1 TIN à 25	—	6900872100	701425
125 x 1,0 x 22,23	5 x 1/25 x 7/8	12200	1 TIN à 25	—	6900873100	701432

* compared to a standard 1mm cutting disc, stored for 6 weeks and subject to a natural ageing process which results in reduction of tool life.

AS 60 W HT Jubilee

evolution

Free hand



The bond of this high performance cutting disc was developed in the laboratory of DRONCO with the aim of an especially cool cut and was completed just in time for our 50th anniversary. In combination with a ceramic coated grain of the latest generation, a new high end tool was born: The 1 mm cutting disc Evolution AS 60 W HT Jubilee.

State of the art. The benefits of this top product:

- ▶ outstanding lifetime
- ▶ excellent cutting speed
- ▶ cool cuts
- ▶ low burr edges

For thin sheets, steel ropes, thin-walled profiles and pipes made of steel or stainless steel.



Lifetime-Plus

- over 30% * more service-life (number of cuts)
- stops the natural ageing process of synthetic resin-bonded discs
- keeps cutting discs fresh until the pack is opened for the first time



Internal tests showed a lifetime extension of 17% in comparison to even our Evolution AS 60 V. Especially produced to ensure the greatest number of fast and precise cuts with minimum power consumption.

DIMENSION MM	DIMENSION INCH	SPEED R.P.M.	CONTENT PC.	SHAPE	ITEM CODE	BAR CODE 4081600
115 x 1,0 x 22,23	4 1/2 x 1/25 x 7/8	13280	1 TIN à 10		6900864100	701869
125 x 1,0 x 22,23	5 x 1/25 x 7/8	12200	1 TIN à 10		6900865100	701876
115 x 1,0 x 22,23	4 1/2 x 1/25 x 7/8	13280	1 TIN à 25		6900845100	701678
125 x 1,0 x 22,23	5 x 1/25 x 7/8	12200	1 TIN à 25		6900846100	701685
Also available 25 pcs. in shrunk plastic foil						
115 x 1,0 x 22,23	4 1/2 x 1/25 x 7/8	13280	25		1111247100	111644
125 x 1,0 x 22,23	5 x 1/25 x 7/8	12200	25		1121247100	121780

* compared to a standard 1mm cutting disc, stored for 6 weeks and subject to a natural ageing process which results in reduction of tool life.

Free hand cutting discs stainless steel/steel 1,6 mm

A 46 R

perfect express

Free hand



The good value solution for thin 1,6 mm metal cutting discs. Good cutting ability at normal lifetime. Almost no burring. Good compromise between the normal 3 mm and the 1,2 mm discs.

Suitable for sheet metal and profiles made from mild steel and stainless steel.

DIMENSION MM	DIMENSION INCH	SPEED R.P.M.	CONTENT PC.	SHAPE	ITEM CODE	BAR CODE 4081600
115 x 1,6 x 22,23	4 1/2 x 1/16 x 7/8	13280	25		1110250100	110036
125 x 1,6 x 22,23	5 x 1/16 x 7/8	12200	25		1120250100	120035



AS 46 T INOX

special

Free hand

★★★★☆



Free of iron and sulphur. Requiring little effort, the special thin cutting disc is easy on man and machine. High cutting speed, long service life, hardly any burring.

Normal steel and stainless steel, particularly suitable for sheet metal and thin-walled profiles. The standard disc used on tank farms and in tank construction.

DIMENSION MM	DIMENSION INCH	SPEED R.P.M.	CONTENT PC.	SHAPE	ITEM CODE	BAR CODE 4081600
115 x 1,6 x 22,23	4 1/2 x 1/16 x 7/8	13280	25		1111250100	111118
125 x 1,6 x 22,23	5 x 1/16 x 7/8	12200	25		1121250100	121117
150 x 1,6 x 22,23	6 x 1/16 x 7/8	10200	25		1153250100	133103
180 x 1,6 x 22,23	7 x 1/16 x 7/8	8600	25		1183250100	143119
230 x 1,9 x 22,23	9 x 5/64 x 7/8	6600	25		1233250100	153118

LIFETIME-PLUS TIN



Over 30% more service life*: With the new Lifetime-Plus concept, we have given the Power Pack tin an amazing new function. Lifetime-Plus seals in the full performance of the discs and keeps it there until the pack is opened for the first time. So these "fresh from the oven" discs ensure to put all their power onto the machine.

Lifetime-Plus

- over 30% * more service life (number of cuts)
- stops the natural ageing process of synthetic resin-bonded discs
- keeps cutting discs fresh until the pack is opened for the first time

DIMENSION MM	DIMENSION INCH	SPEED R.P.M.	CONTENT PC.	SHAPE	ITEM CODE	BAR CODE 4081600
115 x 1,6 x 22,23	4 1/2 x 1/16 x 7/8	13280	1 TIN à 25		6900874100	701449
125 x 1,6 x 22,23	5 x 1/16 x 7/8	12200	1 TIN à 10		6900856100	701265
125 x 1,6 x 22,23	5 x 1/16 x 7/8	12200	1 TIN à 25		6900875100	701456
230 x 1,9 x 22,23	9 x 5/64 x 7/8	6600	1 TIN à 10		6900855100	701258

* compared to a standard 1mm cutting disc, stored for 6 weeks and subject to a natural ageing process which results in reduction of service life.

AS 46 V

evolution express

Free hand

★★★★

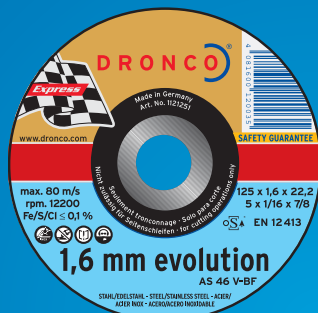

This top disc stands out for high cutting speed in connection with a very high lifetime. Cutting with little or no burrs.

For normal and stainless steel, especially for sheet metal and thin-walled profiles.



DIMENSION MM	DIMENSION INCH	SPEED R.P.M.	CONTENT PC.	SHAPE	ITEM CODE	BAR CODE 4081600
115 x 1,6 x 22,23	4 1/2 x 1/16 x 7/8	13280	25		1111251100	111132
125 x 1,6 x 22,23	5 x 1/16 x 7/8	12200	25		1121251100	121148
180 x 1,6 x 22,23	7 x 1/16 x 7/8	8600	25		1183251100	143171
230 x 1,9 x 22,23	9 x 5/64 x 7/8	6600	25		1233251100	153170

LIFETIME-PLUS TIN



Over 30% more service life*:

With the new Lifetime-Plus concept, we have given the Power Pack tin an amazing new function. Lifetime-Plus seals in the full performance of the discs and keeps it there until the pack is opened for the first time. So these "fresh from the oven" discs ensure to put all their power onto the machine.

Lifetime-Plus

- over 30% * more service life (number of cuts)
- stops the natural ageing process of synthetic resin-bonded discs
- keeps cutting discs fresh until the pack is opened for the first time

DIMENSION MM	DIMENSION INCH	SPEED R.P.M.	CONTENT PC.	SHAPE	ITEM CODE	BAR CODE 4081600
115 x 1,6 x 22,23	4 1/2 x 1/16 x 7/8	13280	1 TIN à 25		6900876100	701463
125 x 1,6 x 22,23	5 x 1/16 x 7/8	12200	1 TIN à 25		6900877100	701470
180 x 1,6 x 22,23	7 x 1/16 x 7/8	8600	1 Tin à 10		6900860100	701289
230 x 1,9 x 22,23	9 x 5/64 x 7/8	6600	1 Tin à 10		6900861100	701296



CERAMAXX

OUR STRONGEST DISCS!

WITH CERAMIC GRAIN OF THE LATEST GENERATION GIVING AN ULTIMATELY INCREASED PERFORMANCE

UNRIVALLED SPEED
 + UNBEATEN AGGRESSION
 + ULTRA LONG LIFETIME
 + MINIMAL ENERGY INPUT
 = HIGHEST EFFICIENCY

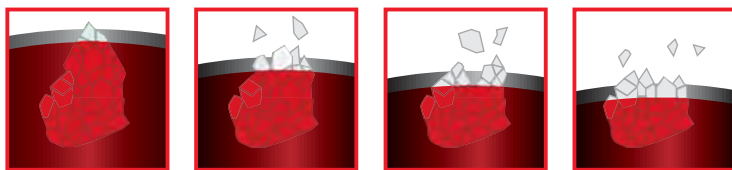

The new bonding technology and the micro-crystalline structure of the ceramic grain ensure a targeted release of new extremely sharp cutting edges. This guarantees the permanent availability of maximum performance of the CeraMaxx cutting and grinding discs - from start to finish. For a maximized cutting speed, removal rate and lifetime.

The sharpest - the best!

DRONCO CeraMaxx discs are among the fastest, most aggressive and most durable on the market, optimizing the work process, saving down time and labour costs giving greatly increased productivity and efficiency.

CeraMaxx cutting discs with ceramic grain of the latest generation

- ▶ Excellent cutting speed = high productivity
- ▶ Lowest energy input = sparing man and machine
- ▶ Clean, burr-free cut = less rework
- ▶ Cool cutting without thermal blueing = less rework
- ▶ Excellent lifetime = reduced disc consumption

ceramic
 INSIDE 2.0



AK 60 V CERAMAXX

evolution



The thin CeraMaxx cutting discs cut ultra fast with little effort massively reducing the energy input. The full cutting performance is therefore achieved at low pressure. For precision cutting accurate to the millimetre and with burr-free edges. Ideal for users from pipeline engineering and construction, shipyards, metal engineering, foundries, commercial vehicle construction, steel construction, plant engineering, crane construction, construction machine production.

The advantages of the CeraMaxx cutting discs prove especially effective in strong profiles and full material. For steel and stainless steel. Fe/S/Cl ≤ 0,1 %



DIMENSION MM	DIMENSION INCH	SPEED R.P.M.	CONTENT PC.	SHAPE	ITEM CODE	BAR CODE 4081600
115 x 1,2 x 22,23	4 1/2 x 3/64 x 7/8	13280	25		1111500100	111989
125 x 1,2 x 22,23	5 x 3/64 x 7/8	12200	25		1121500100	122299
LIFETIME-PLUS TIN						
115 x 1,2 x 22,23	4 1/2 x 3/64 x 7/8	13280	1 TIN à 10		6900820100	702309
125 x 1,2 x 22,23	5 x 3/64 x 7/8	12200	1 TIN à 10		6900821100	702316

AK 46 V CERAMAXX

evolution



The CeraMaxx cutting discs cut ultra fast with little effort massively reducing the energy input. The full cutting performance is therefore achieved at low pressure. Ideal for users from pipeline engineering and construction, shipyards, metal engineering, foundries, commercial vehicle construction, steel construction, plant engineering, crane construction, construction machine production.

The advantages of the CeraMaxx cutting discs prove especially effective in strong profiles and full material. For steel and stainless steel. Fe/S/Cl ≤ 0,1 %



DIMENSION MM	DIMENSION INCH	SPEED R.P.M.	CONTENT PC.	SHAPE	ITEM CODE	BAR CODE 4081600
115 x 1,6 x 22,23	4 1/2 x 1/16 x 7/8	13280	25		1111512100	111828
125 x 1,6 x 22,23	5 x 1/16 x 7/8	12200	25		1121512100	122312
150 x 1,6 x 22,23	6 x 1/16 x 7/8	10200	25		1153511100	133073
LIFETIME-PLUS TIN						
115 x 1,6 x 22,23	4 1/2 x 1/16 x 7/8	13280	1 TIN à 10		6900822100	702323
125 x 1,6 x 22,23	5 x 1/16 x 7/8	12200	1 TIN à 10		6900823100	702330



ACS 46 / ACS 60 T MULTI

special

Free hand

★★★★



The special recipe of this new combi-disc ACS60T-MULTI allows cutting of metal and wall tiles without changing the disc. A special tool for special users, such as plumbers.

For use on stainless steel, mild steel and stone (especially wall tiles).

Three discs in one

- ▶ Combi-disc for stainless steel, steel and wall tiles
- ▶ good cutting performance
- ▶ comfortable cutting
- ▶ no time-consuming disc changes required
- ▶ low-burr to burr-free edges



DIMENSION MM	DIMENSION INCH	SPEED R.P.M.	CONTENT PC.	SHAPE	ITEM CODE	BAR CODE 4081600
115 x 1,2 x 22,23	4 1/2 x 3/64 x 7/8	13280	25		1111360100	111804
125 x 1,2 x 22,23	5 x 3/64 x 7/8	12200	25		1121360100	121803
180 x 1,6 x 22,23	7x1/16x7/8	8600	25		1183360100	143157
230 x 1,9 x 22,23	9x 5/64x7/8	6600	25		1233360100	153606

POWER-PACK-TIN



10 cutting discs in the attractive and popular metal box. A big seller for guaranteed increased turnover.

Each box includes 10 combi-discs ACS 60 T Multi 1,2 mm.

115 x 1,2 x 22,23	4 1/2 x 3/64 x 7/8	13280	1 TIN à 10		6900942100	704808
125 x 1,2 x 22,23	5 x 3/64 x 7/8	12200	1 TIN à 10		6900943100	704815

PLEASE NOTE

This product is also suitable for battery-powered angle grinders in diameters 115 and 125 mm.



Free hand cutting discs stainless steel/steel

AS 46 / AS 60 T INOX FreeCut

special

Free hand

★★★★☆



FreeCut: The Conical Disc. This disc developed by DRONCO (patent pending) is a revolution in its field. The conical form of the disc tapers from the outer edge to the inner edge and gives the disc ideal cutting qualities. No braking effect caused by side friction, no jamming of the disc in the work piece (thus avoiding the dangerous kick-back effect). The cutting only takes place on the face side. The disc is easy to work with: pleasant, quick and safe cutting, good cutting control, no jamming.

For cutting steel and stainless steel, also suitable for non-ferrous metals. Does not contain iron, sulphur or chlorine (each 0.1%). Suitable for thin- and thick-walled profiles and solid material.



Greater safety and precision during use.

- does not jam during cutting
- reduces the dangerous „kick-back“ effect
- less heat generated
- reduced side friction for unhindered cutting
- light, power-saving handling using the FreeCut principle
- less reduction of r.p.m. in the machine - and therefore faster cutting



The cutting disc tapers towards the center

DIMENSION MM	DIMENSION INCH	SPEED R.P.M.	CONTENT PC.	SHAPE	ITEM CODE	BAR CODE 4081600
115x2,0/1,0x22,23	4 1/2x5/64-1/25x7/8	13280	25		111340100	111507
125x2,0/1,0x22,23	5x5/64 - 1/25x7/8	12200	25		1121340100	121506
AS 46 T INOX FreeCut						
150x2,5/2,0x22,23	6x3/32 - 5/64x7/8	10200	25		1153340100	133509
180x3,0/2,0x22,23	7x5/64 - 1/8x7/8	8600	25		1183340100	143508
230x3,0/2,0x22,23	9x5/64 - 1/8x7/8	6600	25		1233340100	153507

POWER-PACK-TIN AS 60 T INOX FREECUT



10 cutting discs in the attractive and popular metal box. A big seller for guaranteed increased turnover.

Each box includes 10 metal cutting discs AS 60 T INOX FreeCut.

115x2,0/1,0x22,23	4 1/2x5/64-1/25x7/8	13280	1 TIN à 10		6900937100	704952
125x2,0/1,0x22,23	5x5/64 - 1/25x7/8	12200	1 TIN à 10		6900947100	704976

PLEASE NOTE

This product is also suitable for battery-powered angle grinders in diameters 115 and 125 mm.





AS 46 / AS 30 T INOX CUT+GRIND special

Free hand

★★★★☆



Cut+Grind: The first cutting disc you are also allowed to use for grinding. The Cut+Grind cuts at a comfortable speed with a thickness of 2.5 mm or 3.5 mm, you can immediately deburr and grind without changing the disc. That saves setup time and therefore money! Good removal rate for light grinding tasks. Of course, the disc complies with the prescribed lateral load for grinding discs of 290 N.

Suitable for normal and stainless steel, both for solid material as well as for profiles. Cutting and grinding in one step.



Deburr or grind immediately without changing the disc.

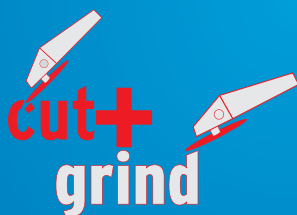

The first thin cutting disc you are also allowed to use for side grinding

- cutting and light grinding work in one step
- good cutting speed
- good removal rate
- no time-consuming disc changes required
- no need to purchase different discs
- for steel or stainless steel

DIMENSION MM	DIMENSION INCH	SPEED R.P.M.	CONTENT PC.	SHAPE	ITEM CODE	BAR CODE 4081600
115 x 2,5 x 22,23	4 1/2 x 3/32 x 7/8	13280	25		1113270100	113600
125 x 2,5 x 22,23	5 x 3/32 x 7/8	12200	25		1123270100	123609
AS 30 T INOX CUT + GRIND						
180 x 3,5 x 22,23	7 x 1/8 x 7/8	8600	25		1183270100	143607

POWER-PACK-TIN AS 46 T INOX CUT + GRIND



5 combined cutting and grinding discs in the attractive and popular metal box. A big seller for guaranteed increased turnover.

Each tin-box includes 5 combined discs AS 46 T INOX CUT+GRIND

115 x 2,5 x 22,23	4 1/2 x 3/32 x 7/8	13280	1 TIN à 5		6900936100	704983
125 x 2,5 x 22,23	5 x 3/32 x 7/8	12200	1 TIN à 5		6900946100	704969

PLEASE NOTE

This product is also suitable for battery-powered angle grinders in diameters 115 and 125 mm.











Free hand cutting discs stainless steel/steel from 2 mm

AS 30 S INOX special Free hand ★★☆☆



Containing no iron, sulphur or chlorine, the recipe of the disc prevents the formation of rust.





DIMENSION MM	DIMENSION INCH	SPEED R.P.M.	CONTENT PC.	SHAPE	ITEM CODE	BAR CODE 4081600
115 x 2,5 x 22,23	4 1/2 x 3/32 x 7/8	13280	25		1111906100	111309
115 x 2,5 x 22,23	4 1/2 x 3/32 x 7/8	13280	25		1113906100	113303
125 x 2,5 x 22,23	5 x 3/32 x 7/8	12200	25		1121906100	121308
125 x 2,5 x 22,23	5 x 3/32 x 7/8	12200	25		1123906100	123302
180 x 2,5 x 22,23	7 x 3/32 x 7/8	8600	25		1181906100	141306
180 x 2,5 x 22,23	7 x 3/32 x 7/8	8600	25		1183906100	143300
230 x 2,5 x 22,23	9 x 3/32 x 7/8	6600	25		1231906100	151305
230 x 2,5 x 22,23	9 x 3/32 x 7/8	6600	25		1233906100	153309

AS 30 T INOX special Free hand ★★☆☆



Containing no iron, sulphur or chlorine, the recipe of the disc prevents the formation of rust.

Special disc designed to cut stainless steel, service life also good in normal steel.

DIMENSION MM	DIMENSION INCH	SPEED R.P.M.	CONTENT PC.	SHAPE	ITEM CODE	BAR CODE 4081600
115 x 2,2 x 22,23	4 1/2 x 3/32 x 7/8	13280	25		1111905100	111293
125 x 2,2 x 22,23	5 x 3/32 x 7/8	12200	25		1121905100	121292
180 x 2,2 x 22,23	7 x 3/32 x 7/8	8600	25		1181905100	141290
230 x 2,2 x 22,23	9 x 3/32 x 7/8	6600	25		1231905100	151299



Free hand cutting discs steel

A 24 R
perfect
Free hand
☆☆☆☆

Good service life and fast cutting at a reasonable price.

All-purpose disc, suitable for cutting all types of metal.

DIMENSION MM	DIMENSION INCH	SPEED R.P.M.	CONTENT PC.	SHAPE	ITEM CODE	BAR CODE 4081600
100 x 3,0 x 16	4 x 1/8 x 5/8	15250	25		1100015100	100006
100 x 3,0 x 16	4 x 1/8 x 5/8	15250	25		1102015100	102000
115 x 3,0 x 22,23	4 1/2 x 1/8 x 7/8	13280	25		1110015100	110005
115 x 3,0 x 22,23	4 1/2 x 1/8 x 7/8	13280	25		1112015100	112009
125 x 3,0 x 22,23	5 x 1/8 x 7/8	12200	25		1120015100	120004
125 x 3,0 x 22,23	5 x 1/8 x 7/8	12200	25		1122015100	122008
150 x 3,0 x 22,23	6 x 1/8 x 7/8	10200	25		1150015100	130003
150 x 3,0 x 22,23	6 x 1/8 x 7/8	10200	25		1152015100	132007
180 x 3,0 x 22,23	7 x 1/8 x 7/8	8600	25		1180015100	140002
180 x 3,0 x 22,23	7 x 1/8 x 7/8	8600	25		1182015100	142006
230 x 3,0 x 22,23	9 x 1/8 x 7/8	6600	25		1230015100	150001
230 x 3,0 x 22,23	9 x 1/8 x 7/8	6600	25		1232015100	152005
300 x 3,5 x 20,0	12 x 1/8 x 3/4	5100	25		1300225100	160093
300 x 3,5 x 22,23	12 x 1/8 x 7/8	5100	25		1300226100	160116

AS 30 S

special

Free hand

★★★★☆



Long service life and good cutting capacity for cost-effective operations.

Professional applications, cutting metal, construction steel or cast.

DIMENSION MM	DIMENSION INCH	SPEED R.P.M.	CONTENT PC.	SHAPE	ITEM CODE	BAR CODE 4081600
100 x 3,0 x 16	4 x 1/8 x 5/8	15250	25		1103115100	103007
115 x 3,0 x 22,23	4 1/2 x 1/8 x 7/8	13280	25		1111115100	111002
115 x 3,0 x 22,23	4 1/2 x 1/8 x 7/8	13280	25		1113115100	113006
125 x 3,0 x 22,23	5 x 1/8 x 7/8	12200	25		1121115100	121001
125 x 3,0 x 22,23	5 x 1/8 x 7/8	12200	25		1123115100	123005
150 x 3,0 x 22,23	6 x 1/8 x 7/8	10200	25		1153115100	133004
180 x 3,0 x 22,23	7 x 1/8 x 7/8	8600	25		1181115100	141009
180 x 3,0 x 22,23	7 x 1/8 x 7/8	8600	25		1183115100	143003
230 x 3,0 x 22,23	9 x 1/8 x 7/8	6600	25		1231115100	151008
230 x 3,0 x 22,23	9 x 1/8 x 7/8	6600	25		1233115100	153002
300 x 3,5 x 20	12 x 1/8 x 3/4	5100	25		1301125100	161007
300 x 3,5 x 22,23	12 x 1/8 x 7/8	5100	25		1301126100	161014
300 x 3,5 x 25,4	12 x 1/8 x 1	6400	25		1301127100	161021
350 x 4,0 x 20	14 x 5/32 x 3/4	5500	10		1351135100	171006
350 x 4 x 25,4	14 x 5/32 x 1	5500	10		1351137100	171020

METAL CUTTING DISCS



AS 30 T

special

Free hand

★★★★☆



The clean cut of this special thin cutting disc enables you to cut sheet metal without contorting the material or producing any burrs.

Sheet steel, particularly of the type used on tank farms and in tank construction.

DIMENSION MM	DIMENSION INCH	SPEED R.P.M.	CONTENT PC.	SHAPE	ITEM CODE	BAR CODE 4081600
115 x 2,0 x 22,23	4 1/2 x 5/64 x 7/8	13280	25		1111055100	111040
115 x 2,0 x 22,23	4 1/2 x 5/64 x 7/8	13280	25		1113055100	113044
115 x 2,5 x 22,23	4 1/2 x 3/32 x 7/8	13280	25		1113060100	113037
125 x 2,0 x 22,23	5 x 5/64 x 7/8	12200	25		1121055100	121049
125 x 2,0 x 22,23	5 x 5/64 x 7/8	12200	25		1123055100	123043
125 x 2,5 x 22,23	5 x 3/32 x 7/8	12200	25		1123060100	123050
180 x 2,0 x 22,23	7 x 5/64 x 7/8	8600	25		1181055100	141047
180 x 2,5 x 22,23	7 x 3/32 x 7/8	8600	25		1183060100	143027
230 x 2,0 x 22,23	9 x 5/64 x 7/8	6600	25		1231055100	151046
230 x 2,5 x 22,23	9 x 3/32 x 7/8	6600	25		1233060100	153040

AS 30 S HT

evolution

Free hand

★★★★☆



With high-temperature treated corundum and balanced bonding, the evolution AS 30 S HT combines the metal removing capacity and cutting performance of a soft disc with the long service life of a hard disc.

Steel, cast, non-ferrous metals.

DIMENSION MM	DIMENSION INCH	SPEED R.P.M.	CONTENT PC.	SHAPE	ITEM CODE	BAR CODE 4081600
115 x 3 x 22,23	4 1/2 x 1/8 x 7/8	13280	25		1111940100	111019
115 x 3,0 x 22,23	4 1/2 x 1/8 x 7/8	13280	25		1113940100	113013
125 x 3,0 x 22,23	5 x 1/8 x 7/8	12200	25		1121940100	121018
125 x 3,0 x 22,23	5 x 1/8 x 7/8	12200	25		1123940100	123012
180 x 3,0 x 22,23	7 x 1/8 x 7/8	8600	25		1181940100	141016
180 x 3,0 x 22,23	7 x 1/8 x 7/8	8600	25		1183940100	143010
230 x 3,0 x 22,23	9 x 1/8 x 7/8	6600	25		1231940100	151015
230 x 3,0 x 22,23	9 x 1/8 x 7/8	6600	25		1233940100	153026

AS 30 V

evolution

Free hand



This is a very hard disc that is characterised by its pronounced all-round qualities and fast cutting capacity. It is particularly suitable for cutting pipes and thin-walled profile sections.

Construction steel, thin-walled profile sections, pipes, etc.

DIMENSION MM	DIMENSION INCH	SPEED R.P.M.	CONTENT PC.	SHAPE	ITEM CODE	BAR CODE 4081600
100 x 3,0 x 16	4 x 1/8 x 5/8	15250	25		1101966100	101201
115 x 3,0 x 22,23	4 1/2 x 1/8 x 7/8	13280	25		1111966100	111200
115 x 3,0 x 22,23	4 1/2 x 1/8 x 7/8	13280	25		1113966100	113204
125 x 3,0 x 22,23	5 x 1/8 x 7/8	12200	25		1121966100	121209
125 x 3,0 x 22,23	5 x 1/8 x 7/8	12200	25		1123966100	123203
180 x 3,0 x 22,23	7 x 1/8 x 7/8	8600	25		1181966100	141214
230 x 3,0 x 22,23	9 x 1/8 x 7/8	6600	25		1231965100	151206
230 x 3,0 x 22,23	9 x 1/8 x 7/8	6600	25		1233965100	153200

AS 36 V

evolution

Free hand



Extremely resistant when cutting materials with sharp edges and thin-walled profiles. Thinner than the AS 30 V and therefore capable of cutting even faster and more precisely.

Construction steel, thin-walled profile sections, pipes, etc.

DIMENSION MM	DIMENSION INCH	SPEED R.P.M.	CONTENT PC.	SHAPE	ITEM CODE	BAR CODE 4081600
100 x 2,2 x 16	4 x 3/32 x 5/8	15250	25		1101070100	101256
115 x 2,2 x 22,23	4 1/2 x 3/32 x 7/8	13280	25		1111070100	111255
125 x 2,2 x 22,23	5 x 3/32 x 7/8	12200	25		1121070100	121254
150 x 2,2 x 22,23	6 x 3/32 x 7/8	10200	25		1151070100	131253
180 x 2,2 x 22,23	7 x 3/32 x 7/8	8600	25		1181070100	141252
230 x 2,2 x 22,23	9 x 3/32 x 7/8	6600	25		1231070100	151251



Free hand cutting discs aluminium





CS 60 ALU	special	Free hand	★★★★☆				
		<p>The outstanding characteristics of the thin cutting discs are now available for aluminium and non-ferrous metals as well. The recipe of the disc guarantees fast cutting without clogging. Long service life.</p>		<p>Specially designed to cut aluminium and non-ferrous metals such as copper, brass, bronze. Also suitable for most synthetic materials.</p>			
DIMENSION MM	DIMENSION INCH	SPEED R.P.M.	CONTENT PC.	SHAPE	ITEM CODE	BAR CODE 4081600	
115 x 1,2 x 22,23	4 1/2 x 3/64 x 7/8	13280	25		1111150100	111163	
125 x 1,2 x 22,23	5 x 3/64 x 7/8	12200	25		1121150100	121063	

PLEASE NOTE
 This product is also suitable for battery-powered angle grinders in diameters 115 and 125 mm.



CS 46 ALU	special	Free hand	★★★★☆				
		<p>Thin, easy cutting disc for clean cuts. Specially designed to cut aluminium and other non-ferrous metals. No clogging, long service life.</p>		<p>Specially designed to cut aluminium and non-ferrous metals such as copper, brass, bronze. Also suitable for most synthetic materials.</p>			
DIMENSION MM	DIMENSION INCH	SPEED R.P.M.	CONTENT PC.	SHAPE	ITEM CODE	BAR CODE 4081600	
150 x 1,6 x 22,23	6 x 1/16 x 7/8	10200	25		1153150100	133066	
180 x 1,6 x 22,23	7 x 1/16 x 7/8	8600	25		1183150100	143041	
230 x 1,9 x 22,23	9 x 5/64 x 7/8	6600	25		1233150100	153033	

Free hand cutting discs for rail sections

AS 24 R BAHN		special	Free hand	★★★★☆		
		Special disc designed to cut all rail sections in short time.		Cutting new and compressed rail sections (e.g. UIC 60, S54 or S49).		
DIMENSION MM	DIMENSION INCH	SPEED R.P.M.	CONTENT PC.	SHAPE	ITEM CODE	BAR CODE 4081600
300 x 3,5 x 22,23	12 x 1/8 x 7/8	5100	25		1301376100	161113
300 x 3,5 x 25,4	12 x 1/8 x 1	5100	25		1301377100	161120
350 x 4,0 x 22,23	14 x 5/32 x 7/8	5500	10		1351386100	171112
350 x 4,0 x 25,4	14 x 5/32 x 1	5500	10		1351387100	171129



Mini cutting discs

AS 46 T Mini cutting discs		special	Free hand	★★★★☆		
		<p>The small cutting disc for pneumatic grinders. This disc offers a means of reaching areas that are difficult to get at. Please choose the right bore.</p>		<p>Perfectly suitable for thin sheet steel. Good performance on construction steel, tool steel and high-speed steel.</p>		
DIMENSION MM	DIMENSION INCH	SPEED R.P.M.	CONTENT PC.	SHAPE	ITEM CODE	BAR CODE 4081600
50 x 1,0 x 6	2 x 1/25 x 1/4	30600	25		6405006100	642520
50 x 2,0 x 6	2 x 5/64 x 1/4	30600	25		6405000100	642421
60 x 2,0 x 6	2 3/8 x 5/64 x 1/4	25450	25		6406001100	642438
76 x 1 x 6	3 x 1/25 x 1/4	20100	25		6407637100	642964
76 x 1,2 x 10	3 x 1/25 x 3/8	20100	25		6407634100	640045
76 x 1,6 x 10	3 x 1/16 x 3/8	20100	25		6407622100	642957

Mini grinding discs can be found on page 61

Tensioning shaft for mini cutting discs					
		<p>The tensioning shaft enables the use of mini cutting discs on straight or cylindrical grinders and drill machines.</p>			
DIMENSION MM	DIMENSION INCH	DIMENSION PC.	CONTENT PC.	ARTIKEL NUMMER	BAR CODE
Tensioning shaft 6 mm x M6	6 mm	1/4	1	6400001100	642575
Tensioning shaft 6 mm x M10	6 mm	1/4	1	6400002100	642582

Discs for stationary cutting machines | Chop-Saws

A 30 S **perfect** **Stationary** ★★☆☆



Soft, all-purpose standard disc for stationary cutting machines.

Particularly suitable for construction steel and tool steel. Good performance on cast.

DIMENSION MM	DIMENSION INCH	SPEED R.P.M.	CONTENT PC.	SHAPE	ITEM CODE	BAR CODE 4081600
300 x 3,5 x 25,4	12 x 1/8 x 1	5100	25	—	2301320100	260205
300 x 3,5 x 32	12 x 1/8 x 1 1/4	5100	25	—	2301340100	260229
350 x 3,5 x 25,4	14 x 1/8 x 1	4400	10	—	2351320100	270204
350 x 3,5 x 32	14 x 1/8 x 1 1/4	4400	10	—	2351340100	270228

AS 30 S **special** **Stationary** ★★☆☆



Long service life, even when used to cut different materials and cutting stability allow working cost-effectively, whether you are cutting profiles, pipes or solid metal.

Metal, construction steel and castings.

DIMENSION MM	DIMENSION INCH	SPEED R.P.M.	CONTENT PC.	SHAPE	ITEM CODE	BAR CODE 4081600
300 x 3,5 x 25,4	12 x 1/8 x 1	6400	25	—	2300020100	260014
300 x 3,5 x 32	12 x 1/8 x 1 1/4	6400	25	—	2300040100	260038
350 x 3,5 x 25,4	14 x 1/8 x 1	5500	10	—	2350020100	270006
350 x 3,5 x 32	14 x 1/8 x 1 1/4	5500	10	—	2350040100	270037
400 x 4,0 x 25,4	16 x 5/32 x 1	4780	10	—	2400020100	280005
400 x 4,0 x 40	16 x 5/32 x 1 9/16	4780	10	—	2400050100	280043

METAL CUTTING DISCS



AS 36 T **special** **Chop-Saw** ★★☆☆

High-quality special disc for "chop saws". (stationary cutting machines with a driving power up to 2.4 kW/3 HP).

Construction steel, tool steel, sheet steel and cast.

DIMENSION MM	DIMENSION INCH	SPEED R.P.M.	CONTENT PC.	SHAPE	ITEM CODE	BAR CODE 4081600
300 x 2,8 x 25,4	12 x 7/64 x 1	5100	25		2300220100	261103
350 x 3,0 x 25,4	14 x 1/8 x 1	4400	10		2350220100	271102
400 x 3,2 x 25,4	16 x 1/8 x 1	4780	10		2400220100	281101

AS 36 S INOX **special** **Chop-Saw** ★★☆☆

High-quality special disc for Chop-Saws. Due to the recipe without using iron, sulphur and chlorine, formation of rust at the edges is prevented.

Special disc for cutting stainless steel, very good lifetime also in mild steel.

DIMENSION MM	DIMENSION INCH	SPEED R.P.M.	CONTENT PC.	SHAPE	ITEM CODE	BAR CODE 4081600
300 x 2,8 x 25,4	12 x 7/64 x 1	5100	25		2300920100	260151
350 x 3,0 x 25,4	14 x 1/8 x 1	4400	10		2350920100	270150

PLEASE NOTE

Cutting discs for use with stationary machines - from a swing cutting machine right up to a fully automatic machine with a control console and a closed working area. When choosing cutting discs for a stationary machines, please observe the maximum peripheral speed of 80 m/s or 100 m/s as recommended by the manufacturer. DRONCO also supplies discs for so-called "chop saws". These are swing-cutting machines with a driving power up to 2.4 kW/3 HP. Stationary cutting discs must never be used on free-hand machines!

Some general information

The following general information gives you the best possible overview about the features of our products.

1 Description

Compiled for cutting discs as follows:

C/CS – silicone carbide is the abrasive grain for cutting stone.

24 – indicates the grit size. The higher the number, the finer the grit. E.g.: 24 rough | 30 medium hard | 36 hard.

R – the second letter indicates the hardness of the disc. The further into the alphabet, the harder the disc.

BF – resin bonded, fibre- reinforced

2 Product lines

perfect | evolution | special
Explanation see next page.

3 Green background

Is the colour coding for stone cutting discs.

4 Safety standards

Our products comply with the highest safety standards and regulations:

EN 12413 – cutting and grinding wheels

oSA⁺ – organisation for the safety of abrasives.

5 Expiry date

This quality cutting disc can be used without any restrictions until the indicated date.
(V month/year)

6 Measurements

Consist of (diameter of the disc)

x (thickness of the disc)

x (bore size).

Measurements given in mm and inch.

7 Max. rpm.

Indicates the permitted maximum speed.

8 Safety information

Security information: For your own safety. Please follow!

9 Red bar

Indicates 80 m/s as permitted peripheral speed.

Green bar

Indicates 100 m/s as permitted peripheral speed.

10 Made in Germany

Stands for proven quality - most of our products are manufactured and tested in Germany.

11 www.dronco.com

24 hr service on our website
- we are always there when you need us!

9 Safety information



STONE CUTTING DISCS



STONE CUTTING DISCS

DRONCO
Made in Germany

Express

www.dronco.com

max. 80 m/s
rpm. 12200

125 x 1,2 x 22,23
5 x 3/64 x 7/8"

EN 12413

1,2 mm perfect
C 60 R-BF

STEIN - STONE - PIERRE
PIEDRA - PIETRA

www.dronco.info/safety

D-95632 Wunsiedel, Wiesenmühle 1
Art.-No. 1125000

4 081600 120042

Seulement tronçonnage · Solo para corte · non sbavare
Nicht zulässig für Seitenschleifen · for cutting operations only

2018/02

2018

10

11

9

8

7

6

5

4

3

2

1

Product lines

For craftsmen or industrial use - two precisely co-ordinated product lines offer the right cutting disc for every user and every application. All discs comply with the relevant regulations, have a high specific cutting capacity and guarantee a maximum of safety.



perfect line

The best-seller. Everybody is convinced from its excellent price/performance ratio.

- good quality
- good lifetime
- good cutting efficiency



special line

Also in stone cutting discs, our special line offers specific solutions for industry and quality orientated craftsmen.

- very good quality
- very good cutting efficiency
- very good economic efficiency



Application chart stone cutting discs																	
	Page	Asphalt	Concrete	Roof tiles	Porous concrete	Granite	Sand-lime stone	Clinker brick	Marble	Tiles	Fireproof clay	Slate	Terrazzo	Earthenware pipes	Exposed aggregate concrete	Brick	Ductile pipes
<ul style="list-style-type: none"> ●● very suitable ● suitable ○ limited suitable 																	
▼ FREE HAND STONE CUTTING DISCS																	
C 60 R PERFECT EXPRESS	48		○	○	○	○		○	●●	●●	○	●●	○	○		○	
C 46 R PERFECT EXPRESS	49		○	○	○	○		○	●●	●●	○	●●	○	○		○	
C 24 R PERFECT	50	○	●	●	●	○	●	○	●	●	○	●	●	●	●	●	○
CS 24 R SPECIAL	51	○	●●	●●	●	●	●	●●	●	●	●	●	●	●●	●●	●●	○
▼ FREE HAND ASPHALT/DUCTILE CUTTING DISCS																	
CS 30 SPECIAL	51	●●	●	●●	●●	○	●●	●	○	○	●	○	○	○	●	●	●●



Professional application

Top product: extremely fast cutting, outstanding service life, minimum effort



Demanding application

Very good cutting performance, high service life









Standard application

Good cutting performance, good service life

You can get DRONCO stone cutting discs in different performance classes - from a standard product for occasional use up to the high-end product for professional applications.

Free hand stone cutting discs

C 60 R		perfect express	Free hand	★★★★☆		
		<p>The excellent properties of thin cutting discs now available for stone: Incredibly fast cut, cutting edges absolutely free of chipping. Comfortable use due to reduced noise output and vibration. Up to 50% less development of dust during cutting.</p>		<p>Outstanding suitability for cutting tiles, marble, window shelves, slates etc.</p> 		
DIMENSION MM	DIMENSION INCH	SPEED R.P.M.	CONTENT PC.	SHAPE	ITEM CODE	BAR CODE 4081600
115 x 1,2 x 22,23	4 1/2 x 3/64 x 7/8	13280	25		115000100	110043
125 x 1,2 x 22,23	5 x 3/64 x 7/8	12200	25		1125000100	120042
POWER-PACK TIN C 60 R						
		<p>10 stone cutting discs in the attractive and popular metal box. A big seller for guaranteed increased turnover.</p>		<p>Each box includes 10 stone cutting discs C 60 R.</p>		
115 x 1,2 x 22,23	4 1/2 x 3/64 x 7/8	13280	1 Tin à 10		6900955100	701074
125 x 1,2 x 22,23	5 x 3/64 x 7/8	12200	1 Tin à 10		6900965100	701081



C 46 R

perfect express

Free hand

☆☆☆



The excellent properties of thin cutting discs now available for stone: Incredibly fast cut, cutting edges absolutely free of chipping. Comfortable use due to reduced noise output and vibration. Up to 50% less abrasive dust during cutting.

For cutting floor tiles, wall tiles, marble, window shelves, slates, etc.



DIMENSION MM	DIMENSION INCH	SPEED R.P.M.	CONTENT PC.	SHAPE	ITEM CODE	BAR CODE 4081600
230 x 1,9 x 22,23	9 x 5/64 x 7/8	6600	25		1238250100	157116

DRONCO Express®: Definitely Faster!



The asset in speed

- ▶ much higher cutting speed
- ▶ definitely faster cutting

The asset in precision

- ▶ excellent clean cut
- ▶ edges low in burrs and free of chipping
- ▶ minimum loss of material

The asset in comfort

- ▶ lowest possible force input
- ▶ at equal contact pressure
- ▶ a minimum of noise
- ▶ low in vibration
- ▶ little development of dust

C 24 R

perfect

Free hand

★★★★



Good service life and fast cutting at a reasonable price. The craftsman's disc that has proved itself in millions of cutting operations.

All types of material found on the construction site, such as concrete, stone, roof tiles, sand-lime stone.

DIMENSION MM	DIMENSION INCH	SPEED R.P.M.	CONTENT PC.	SHAPE	ITEM CODE	BAR CODE 4081600
100 x 3 x 16	4 x 1/8 x 5/8	15250	25		1105015100	105001
100 x 3 x 16	4 x 1/8 x 5/8	15250	25		1107015100	107005
115 x 3 x 22,23	4 1/2 x 1/8 x 7/8	13280	25		1115015100	115000
115 x 3 x 22,23	4 1/2 x 1/8 x 7/8	13280	25		1117015100	117004
125 x 3 x 22,23	5 x 1/8 x 7/8	12200	25		1125015100	125009
125 x 3 x 22,23	5 x 1/8 x 7/8	12200	25		1127015100	127003
180 x 3 x 22,23	7 x 1/8 x 7/8	8600	25		1185015100	145007
180 x 3 x 22,23	7 x 1/8 x 7/8	8600	25		1187015100	147001
230 x 3 x 22,23	9 x 1/8 x 7/8	6600	25		1235015100	155006
230 x 3 x 22,23	9 x 1/8 x 7/8	6600	25		1237015100	157000
300 x 4,0 x 22,23	12 x 5/32 x 7/8	5100	25		1305036100	165012



STONE CUTTING DISCS



CS 24 R

special

Free hand

★★★★☆



Stone cutting disc for diverse uses on the construction site.

Cuts granite, concrete, brick and other construction site materials effectively. Also perfectly suitable for ceramic, porcelain and marble.

DIMENSION MM	DIMENSION INCH	SPEED R.P.M.	CONTENT PC.	SHAPE	ITEM CODE	BAR CODE 4081600
115 x 3 x 22,23	4 1/2 x 1/8 x 7/8	13280	25		1116015100	116007
115 x 3 x 22,23	4 1/2 x 1/8 x 7/8	13280	25		1118015100	118001
125 x 3 x 22,23	5 x 1/8 x 7/8	12200	25		1126015100	126006
125 x 3 x 22,23	5 x 1/8 x 7/8	12200	25		1128015100	128000
180 x 3 x 22,23	7 x 1/8 x 7/8	8600	25		1186015100	146004
230 x 3 x 22,23	9 x 1/8 x 7/8	6600	25		1236015100	156003
230 x 3 x 22,23	9 x 1/8 x 7/8	6600	25		1238015100	158007
300 x 4 x 20	12 x 5/32 x 3/4	5100	25		1306035100	166002
300 x 4 x 22,23	12 x 5/32 x 7/8	5100	25		1306036100	166019
350 x 4 x 20	14 x 5/32 x 3/4	5500	10		1356035100	176001
350 x 4 x 25,4	14 x 5/32 x 1	5500	10		1356037100	176025

Free hand asphalt/ductile cutting discs

CS 30 ASPHALT/DUKTIL

special

Free hand

★★★★☆



Very good special disc which shows excellent results not only in cement/cast composition of ductile pipes but also in asphalt and other constructions site materials.

Ductile pipes, porous concrete, roof tiles, sand-lime stone and earthenware pipes. Very economic in asphalt (even with aggregates).

DIMENSION MM	DIMENSION INCH	SPEED R.P.M.	CONTENT PC.	SHAPE	ITEM CODE	BAR CODE 4081600
300 x 4 x 20	12 x 5/32 x 3/4	5100	25		1306135100	166040
350 x 4 x 20	14 x 5/32 x 3/4	5500	10		1356135100	176087

Some general information

The following information gives you the best possible overview about the features of our products.

1 Description

Compiled for grinding discs as follows:

A/CS – aluminium oxide/silicone carbide is the abrasive grain for grinding metal/stone.

AZ – zirconium corundum is the abrasive grit for better life time and grinding efficiency.

30 – indicates the grit size. The higher the number, the finer the grit.

E.g.: 24 rough | 30 medium | 36 fine ...

S – the second letter indicates the hardness of the disc. The further into the alphabet, the harder the disc.

2 Product lines

perfect | evolution | special
Explanation see next page.

3 Red background

Is the colour coding for grinding discs.

4 Safety standards

Our products comply with the highest safety standards and regulations:

EN 12413 - cutting and grinding wheels

ISO 9001 - organisation for the safety of abrasives.

5 Expiry date

This quality cutting disc can be used without any restrictions until the indicated date.

(V month/year)

6 FE/S/Cl ≤ 0,1%

Free from iron, sulphur and chlorine.

Special disc for cutting stainless steel.

7 Measurements

Consist of (diameter of the disc)

x (thickness of the disc)

x (bore size).

Measurements given in mm and inch.

8 Max. rpm.

Indicates the

permitted maximum speed.

9 Red bar

Indicates 80 m/s as

permitted peripheral speed.

Green bar

Indicates 100 m/s as

permitted peripheral speed.

10 Safety information

Security information: For your own safety.

Please follow!

11 Made in Germany

Stands for proven quality -

most of our products are manufactured and tested in Germany.

12 www.dronco.com

24 hr service on our website

- we are always there when you need us!

9 Safety information





Product lines

For craftsmen or industrial use - three precisely co-ordinated product lines offer the right grinding disc for every user and every application. All discs comply with the relevant regulations, have a high specific grinding capacity and guarantee a maximum of safety.



perfect line

The best-seller. Not only brilliant with its price/performance ratio. It has proven itself a million times. The perfect line shows best results on every angle grinder.

- resin bonded
- reinforced with glass fibre
- good lifetime
- good removal rate



special line

Professional use needs for every application the right disc. Therefore abrasive grits and bonds match exactly the material - this increases the performance and minimises the working time.

- very good lifetime
- very „agressive“ disc
- very good removal rate
- very good economic efficiency



evolution line

The high end line for highest demands. These grinding discs have a brilliant lifetime and outstanding grinding efficiency at minimal effort.

- outstanding lifetime
- best raw materials
- maximum removal rate



Application chart grinding discs metal

	page	Unalloyed and alloyed construction steel	Very solid construction steel	Tool steel	High-alloy special steel	Sheet steel	Stainless sheet steel	Welding seams	Cast	Non-ferrous metals
<ul style="list-style-type: none"> ●● very suitable ● suitable ○ limited suitable 										
GRINDING DISCS STEEL										
A 30 T PERFECT	56	●●	○	○		●		○	○	○
AS 30 R SPECIAL	56	●●	●●	●●		●		●●	●	●
AS 24/30 T SPECIAL	57	●●	●	●		●●		●●	○	●
GRINDING DISCS STAINLESS STEEL/STEEL										
AS 30 S INOX SPECIAL	57	●	●	●	●●	●	●●	●	●	○
AS 30 T INOX SPECIAL	58	●	●	●●	●●	●	●●	●●	●	○
AZ 30 S EVOLUTION	58	●●	●	●●	●●	●	●●	●●	●●	●
AZ 30 T EVOLUTION	58	●●	●	●●	●●	●	●●	●●	●●	●
AK 36 T EVOLUTION CERAMAXX	59	●●	●●	●●	●●	●●	●●	●●	●●	●
AK 24 V EVOLUTION CERAMAXX	59	●●	●●	●●	●●	●●	●●	●●	●●	●
GRINDING DISCS CAST										
AS 24 S CAST/IRON SPECIAL	60	○				○			●●	●●
GRINDING DISCS ALUMINIUM										
AS 46 ALU SPECIAL	60	○				○			●	●●
MINI-GRINDING DISCS										
AS 46 T MINI SPECIAL	61	●	●	●	○	●	○	○	○	○

Application chart grinding discs stone

	page	Concrete	Granite	Sand-lime stone	Clinker brick	Marble	Porcelain	Fireproof clay	Slate	Terrazzo	Earthenware pipes	Exposed aggregate concrete
<ul style="list-style-type: none"> ●● very suitable ● suitable ○ limited suitable 												
GRINDING DISCS STONE												
CS 30 S SPECIAL	61	●●	●	●●	●	●	●	●	●	●	●	●



Professional application

Top product: extremely aggressive stock removal, outstanding service life, minimum effort



Demanding application

Very good stock removal, high service life



Standard application

Good stock removal, good service life

You can get DRONCO grinding discs in different performance classes - from a standard product for occasional use up to the high-end product for professional applications.

Grinding discs steel

A 30 T **perfect** **metal** ★★☆☆



Good all-purpose disc with a good service life.

All types of metal, primarily sheet steel, construction steel and welding seams.

DIMENSION MM	DIMENSION INCH	SPEED R.P.M.	CONTENT PC.	SHAPE	ITEM CODE	BAR CODE 4081600
100 x 6 x 16	4 x 1/4 x 5/8	15250	10		3106040100	300024
115 x 6 x 22,23	4 1/2 x 1/4 x 7/8	13280	10		3116040100	310023
125 x 6 x 22,23	5 x 1/4 x 7/8	12200	10		3126040100	320022
150 x 6 x 22,23	6 x 1/4 x 7/8	10200	10		3156040100	330021
180 x 6 x 22,23	7 x 1/4 x 7/8	8600	10		3186041100	340020
180 x 8 x 22,23	7 x 5/16 x 7/8	8600	10		3188040100	340082
230 x 6 x 22,23	9 x 1/4 x 7/8	6600	10		3236041100	350029
230 x 8 x 22,23	9 x 5/16 x 7/8	6600	10		3238040100	350067

AS 30 R **special** **metal** ★★☆☆



Very good grinding disc with a particularly long service life.

All types of construction steel and tool steel, welding seams, cast.

DIMENSION MM	DIMENSION INCH	SPEED R.P.M.	CONTENT PC.	SHAPE	ITEM CODE	BAR CODE 4081600
115 x 6 x 22,23	4 1/2 x 1/4 x 7/8	13280	10		3116500100	313000
125 x 4 x 22,23	5 x 5/32 x 7/8	12200	10		3124500100	323016
125 x 6 x 22,23	5 x 1/4 x 7/8	12200	10		3126500100	323009
150 x 6 x 22,23	6 x 1/4 x 7/8	10200	10		3156500100	333008
180 x 6 x 22,23	7 x 1/4 x 7/8	8600	10		3186500100	343014
230 x 6 x 22,23	9 x 1/4 x 7/8	6600	10		3236500100	353006



AS 24/30 T

special

metal

★★★★



All-purpose grinding disc with medium-hard bonding for light grinding operations, offering good metal removal rate and a long service life.

Very solid construction steel, tool steel, high-speed steel, and sheet steel.

DIMENSION MM	DIMENSION INCH	SPEED R.P.M.	CONTENT PC.	SHAPE	ITEM CODE	BAR CODE 4081600
115 x 6 x 22,23	4 1/2 x 1/4 x 7/8	13280	10		3116520100	313055
125 x 6 x 22,23	5 x 1/4 x 7/8	12200	10		3126520100	323047
150 x 6 x 22,23	6 x 1/4 x 7/8	10200	10		3156520100	333046
180 x 6 x 22,23	7 x 1/4 x 7/8	8600	10		3186520100	343052
230 x 6 x 22,23	9 x 1/4 x 7/8	6600	10		3236520100	353068

Grinding discs stainless steel/steel

AS 30 S INOX

special

metal

★★★★☆



Free of iron, chlorine and sulphur, medium-hard special disc with high grinding performance for rust-free surfaces. FE / S / Cl ≤ 0,1%

High-alloy special steel, high-alloy stainless steel and stainless steel sheet.

DIMENSION MM	DIMENSION INCH	SPEED R.P.M.	CONTENT PC.	SHAPE	ITEM CODE	BAR CODE 4081600
100 x 6 x 16	4 x 1/4 x 5/8	15250	10		3106540100	303063
115 x 4 x 22,23	4 1/2 x 5/32 x 7/8	13280	10		3114540100	313093
115 x 6 x 22,23	4 1/2 x 1/4 x 7/8	13280	10		3116540100	313062
125 x 4 x 22,23	5 x 5/32 x 7/8	12200	10		3124540100	323030
125 x 6 x 22,23	5 x 1/4 x 7/8	12200	10		3126540100	323061
150 x 4 x 22,23	6 x 5/32 x 7/8	10200	10		3154540100	333053
150 x 6 x 22,23	6 x 1/4 x 7/8	10200	10		3156540100	333060
180 x 6 x 22,23	7 x 1/4 x 7/8	8600	10		3186540100	343090
230 x 6 x 22,23	9 x 1/4 x 7/8	6600	10		3236540100	353051

AS 30 T INOX

special

metal

★★★★



Our premium grinding disc for applications on stainless steel. Extremely long service life at comfortable, vibration-optimized operation. Outstanding stock removal rate and easy to use. No clogging, no chattering – a special tool for special applications!

FE/S/CI ≤ 0,1%

For stainless steel, high-alloy stainless steel, sheet stainless steel, rust and acid resistant steel, non-ferrous metal.

DIMENSION MM	DIMENSION INCH	SPEED R.P.M.	CONTENT PC.	SHAPE	ITEM CODE	BAR CODE 4081600
115 x 7 x 22,23	4 1/2 x 9/32 x 7/8	13280	10		3117545100	313307
125 x 7 x 22,23	5 x 9/32 x 7/8	12200	10		3127545100	323306
180 x 7 x 22,23	7 x 9/32 x 7/8	8600	10		3187545100	343304
230 x 7 x 22,23	9 x 9/32 x 7/8	6600	10		3237545100	353303

AZ 30 S

evolution

metal

★★★★



Medium-hard grinding disc with zirconium corundum which distinguishes especially through a very high life-time and a outstanding removal rate at minimum effort. FE/S/CI ≤ 0,1%

Stainless steel, high alloyed stainless steel, stainless sheet steel, non ferrous metal, cast

DIMENSION MM	DIMENSION INCH	SPEED R.P.M.	CONTENT PC.	SHAPE	ITEM CODE	BAR CODE 4081600
115 x 6 x 22,23	4 1/2 x 1/4 x 7/8	13280	10		3116560100	313253
125 x 6 x 22,23	5 x 1/4 x 7/8	12200	10		3126560100	323252
150 x 6 x 22,23	6 x 1/4 x 7/8	10200	10		3156560100	333251
180 x 6 x 22,23	7 x 1/4 x 7/8	8600	10		3186560100	343250
230 x 6 x 22,23	9 x 1/4 x 7/8	6600	10		3236560100	353259

AZ 30 T

evolution

metal

★★★★



Grinding disc containing 25% zirconium. The perfect mixture of zirconium corundum and semi-friable fused aluminium oxide offers the following advantages:

- ▶ very high stock removal rate (even on stainless steel)
- ▶ great lifetime
- ▶ excellent price-performance-ratio

For stainless steel, high alloyed stainless steel, stainless steel sheets, non ferrous metals and cast. FE/S/CI ≤ 0,1 %.

DIMENSION MM	DIMENSION INCH	SPEED R.P.M.	CONTENT PC.	SHAPE	ITEM CODE	BAR CODE 4081600
115 x 6,0 x 22,23	4 1/2 x 1/4 x 7/8	13280	10		3116550100	313215
125 x 6,0 x 22,23	5 x 1/4 x 7/8	12200	10		3126550100	323214
230 x 6,0 x 22,23	9 x 1/4 x 7/8	6600	10		3236550100	353266



CERAMAXX

OUR STRONGEST DISCS!

WITH CERAMIC GRAIN OF THE LATEST GENERATION GIVING AN ULTIMATELY INCREASED PERFORMANCE

- ▶ Durably aggressive removal performance = high productivity
- ▶ Lowest energy input = sparing for man and machine
- ▶ Quiet-running and smooth grinding = comfortable handling
- ▶ Cool grinding without thermal blueing = less rework
- ▶ Excellent lifetime = reduced disc consumption

AK 36 T CeraMaxx

evolution

metal

★★★★



The Evolution AK 36 T is the first 3 mm grinding disc with ceramic grain which does not require a backing pad and which can simultaneously be used as a fully-fledged cutting disc. CeraMaxx discs are among the fastest, most aggressive and most durable on the market giving greatly increased productivity and efficiency with maximum removal rates and an unmatched speed of grinding performance.

Ideal for users from pipeline engineering and construction, shipyards, metal engineering, foundries, commercial vehicle construction, steel construction, plant engineering, crane construction, construction machine production.

Combined grinding and cutting disc for the preparation and removal of welding seams, removal of welding splatter, descaling, rough deburring and grinding on stainless steel and steel. Fe/S/Cl ≤ 0,1 %.



DIMENSION MM	DIMENSION INCH	SPEED R.P.M.	CONTENT PC.	SHAPE	ITEM CODE	BAR CODE 4081600
115 x 3 x 22,23	4 1/2 x 1/8 x 7/8	13280	10		3113551100	311112
125 x 3 x 22,23	5 x 1/8 x 7/8	12200	10		3123551100	320145

AK 24 V CeraMaxx

evolution

metal

★★★★



High performance grinding disc with increased productivity and up to three times higher material removal compared to standard discs. Maximum aggressiveness with comfortable handling. Better efficiency thanks to an enormous lifetime. Excellent performance at low pressure.



Ideal for users from pipeline engineering and construction, shipyards, metal engineering, foundries, commercial vehicle construction, steel construction, plant engineering, crane construction, construction machine production.

CeraMaxx grinding discs are ideally suitable for demanding grinding works: Preparation and removal of welding seams, removal of welding splatter, descaling, rough deburring and grinding on stainless steel and steel. Fe/S/Cl ≤ 0,1 %.









DIMENSION MM	DIMENSION INCH	SPEED R.P.M.	CONTENT PC.	SHAPE	ITEM CODE	BAR CODE 4081600
115 x 7 x 22,23	4 1/2 x 9/32 x 7/8	13280	10		3117561100	313192
125 x 4 x 22,23	5 x 5/32 x 7/8	12200	10		3124560100	323191
125 x 7 x 22,23	5 x 9/32 x 7/8	12200	10		3127560100	323405
150 x 7 x 22,23	6 x 9/32 x 7/8	10200	10		3157560100	333084
180 x 7 x 22,23	7 x 9/32 x 7/8	8600	10		3187560100	343403
230 x 7 x 22,23	9 x 9/32 x 7/8	6600	10		3237561100	353211

▼ Grinding discs cast



AS 24 S Cast/Iron		special	metal	★★★★☆		
		<p>New grinding disc for the industrial processing of cast-iron. This disc is made to ensure an excellent removal rate together with an extremely long service life. Low vibration for operator convenience therefore giving longer usage are the prime features of this development. No clogging, no chattering - a special tool for special applications!</p>		<p>High performance blade for use on cast-iron.</p>		
DIMENSION MM	DIMENSION INCH	SPEED R.P.M.	CONTENT PC.	SHAPE	ITEM CODE	BAR CODE 4081600
180 x 7 x 22,23	7 x 9/32 x 7/8	8600	10		3187860100	343182
230 x 7 x 22,23	9 x 9/32 x 7/8	6600	10		3237860100	353181

▼ Grinding discs aluminium

AS 46 ALU		special	metal	★★★★☆		
		<p>Special disc designed to grind aluminium and non-ferrous metals. The composition of the material prevents clogging and improves performance and service life noticeably.</p>		<p>Copper, aluminium alloys, brass, bronze, cast.</p>		
DIMENSION MM	DIMENSION INCH	SPEED R.P.M.	CONTENT PC.	SHAPE	ITEM CODE	BAR CODE 4081600
115 x 6 x 22,23	4 1/2 x 1/4 x 7/8	13280	10		3116580100	313079
125 x 6 x 22,23	5 x 1/4 x 7/8	12200	10		3126580100	323078
150 x 6 x 22,23	6 x 1/4 x 7/8	10200	10		3156580100	333077
180 x 6 x 22,23	7 x 1/4 x 7/8	8600	10		3186580100	343076
230 x 6 x 22,23	9 x 1/4 x 7/8	6600	10		3236580100	353075







Mini grinding discs

AS 46 T	special	metal	★★★★☆			
		<p>The small grinding disc for pneumatic grinders. This disc offers a means of reaching areas that are difficult to get at.</p> <p>Good performance on construction steel, tool steel and high-speed steel.</p>				
DIMENSION MM	DIMENSION INCH	SPEED R.P.M.	CONTENT PC.	SHAPE	ITEM CODE	BAR CODE 4081600
60 x 6 x 6	2 3/8 x 1/4 x 1/4	25450	10		6406000100	642551
76 x 6 x 10	3 x 1/4 x 3/8	20100	10		6407600100	642742

Mini cutting discs and tensioning shafts for mini grinding discs can be found on page 40.

Grinding discs stone

CS 30 S	special	stone	★★★★☆			
		<p>Medium-hard grinding disc with very good removal rate and a long service life, suitable for grinding both edges and surfaces.</p> <p>Grinding stone and concrete.</p>				
DIMENSION MM	DIMENSION INCH	SPEED R.P.M.	CONTENT PC.	SHAPE	ITEM CODE	BAR CODE 4081600
115 x 6 x 22,23	4 1/2 x 1/4 x 7/8	13280	10		3116660100	313109
125 x 6 x 22,23	5 x 1/4 x 7/8	12200	10		3126660100	323108
180 x 6 x 22,23	7 x 1/4 x 7/8	8600	10		3186660100	343106
230 x 6 x 22,23	9 x 1/4 x 7/8	6600	10		3236660100	353105

Some general information

The following information gives you the best possible overview about the features of our products.

1 Description

A – normal corundum is the abrasive band for mild steel.
 AZ – Zirconium corundum is the abrasive band for stainless steel.
 AK - Ceramic grain is the new, self sharpening abrasive band for steel, stainless steel, high alloy steel, brass and bronze.
 40 – indicates the grit size.
 The higher the number, the finer the grit.
 E.g.: 40 rough | 60 medium
 80 fine | 120 very fine

2 Product lines

perfect | evolution | special
 Explanation see next page.

3 Yellow background

Is the colour coding for flap discs.

4 Safety standards

Our products comply with the highest safety standards and regulations:
 EN 13743 - flap discs
 OSA - organisation for the safety of abrasives

5 Measurements

Consist of (diameter of the disc)
 x (bore size).
 Measurements given in mm and inch.

6 Max. rpm.

Indicates the permitted maximum speed.

7 Red bar

Indicates 80 m/s as permitted peripheral speed.

8 Safety information

For your own safety. Please follow!

9 www.dronco.com

24 hr service on our website
 - we are always there when you need us!

8 Safety information





4

9

8

2

3

1

7

8

6

5

Fächerschleifscheibe
Flap-Disc
Disque à lamelles
Discos de láminas
Lamellrondeller



EN 13743

DRONCO GmbH
D-95632 Wunsiedel
Wiesenmühle 1
www.dronco.com



Edelstahl
Stainless Steel
Acier Inoxydable
Acero Inoxidable
Acciaio Inossidabile



4 081600 521726

Art. No.
52 12 187
max. 80m/s
rpm. 12200
5x7/8"

Ø 125 mm
⌀ 22,23mm

Korn|Grit
Grain|Grano
80

special
G-AZ A

Product lines

For craftsmen or industrial use - three precisely coordinated product lines offer the right flap disc for every user and every application. All discs comply with the relevant regulations, have a high specific grinding capacity and guarantee a maximum of safety.



perfect line

The best-seller. It has proven itself a million times. The abrasive band made of normal corundum enables a good material removal rate compared with a very attractive price.

- good material removal rate
- good lifetime
- very good price-performance ratio



special line

Effective, long-lasting and economical. Flap discs from our special line with abrasive bands made of zirconium corundum are optimised for grinding on edges and surfaces in industrial use as well as for craftsmen - this increases the performance and reduces the working time.

- very good lifetime
- no clogging
- very good material removal rate
- easy working



evolution line

The high-end line for highest demands. These flap discs offer outstanding lifetime, plus high removal rate with minimum effort.

- outstanding lifetime
- best raw materials
- outstanding material removal rate
- optimum efficiency



Professional application

Top product: extremely aggressive stock removal, outstanding service life, minimum effort



Demanding application

Very good stock removal, high service life



Standard application

Good stock removal, good service life

You can get DRONCO flap discs in different performance classes - from a standard product for occasional use up to the high-end product for professional applications.



Application chart flap discs

	Page	unalloyed and alloyed construction steel	Very solid construction steel	tool steel	high alloy special steel	sheet steel	stainless sheet steel	welding seams	cast	non-ferrous metals	wood	plastic	filling compound	stone
FLAP DISCS NORMAL CORUNDUM														
PERFECT G-A	66	●●	●●	●●	●	●●	●	●	●	●	●	●	●	
FLAP DISCS ZIRCONIUM CORUNDUM														
SPECIAL G-AZ A	67	●●	●●	●●	●●	●●	●●	●	●●	●	●	●	●	
SPECIAL K-AZ A	68	●●	●●	●●	●●	●●	●●	●	●●	●	●	●	●	
SPECIAL J-AZ A JET	69	●●	●●	●●	●●	●●	●●	●	●●	●	●	●	●	
SPECIAL G-AZ	70	●●	●●	●●	●●	●●	●●	●	●●	●	●	●	●	
EVOLUTION G-AZ MAXX	71	●●	●●	●●	●●	●●	●●	●	●●	●	●	●	●	
FLAP DISCS CERAMIC GRAIN														
EVOLUTION G-AK	72	●●	●●	●●	●●	●●	●●	●	●●	●●	●	●	●	
EVOLUTION J-AK JET	73	●●	●●	●●	●●	●●	●●	●	●●	●●	●	●	●	
FLAP DISCS SILICON CARBIDE														
PERFECT G-C	74													●●

Evolution AZ Maxx zirconium corundum flap disc

- same advantages as AZA
- increased height of lamellas
- steeper arrangement of lamellas
- aggressive material removal rate

Perfect A normal corundum flap disc

- tough and hard abrasive grain
- good removal capacity, especially for surface work
- good service life

Perfect C silicon carbide flap disc

- polyester backing
- very hard abrasive grain
- for stone treatment
- good removal rate

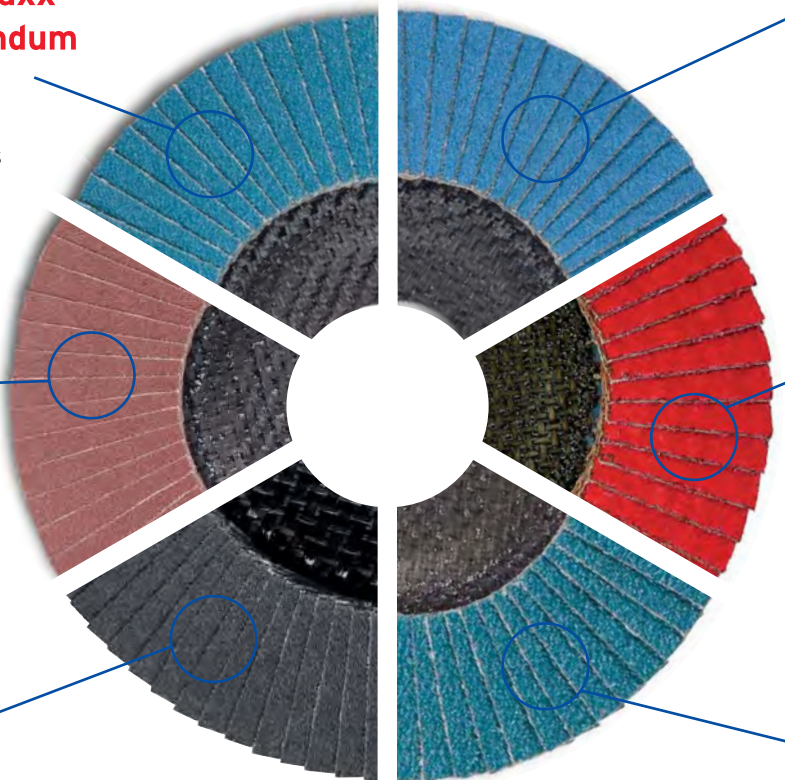

Special AZ zirconium corundum flap disc

- abrasive grain is less hard, but very tough
- for working on edges and stainless steel
- brilliant grinding capacity
- outstanding service life

Evolution AK ceramic grain flap disc

- self-sharpening
- robust polyester backing
- permanent extremely high stock removal
- cool grinding on surfaces and edges
- improved service life

Special AZA zirconium corundum flap disc

- support of the abrasive band consists of a cotton twill
- for surface grinding on steel and stainless steel
- good grinding capacity
- outstanding service life
- no clogging up

tapered

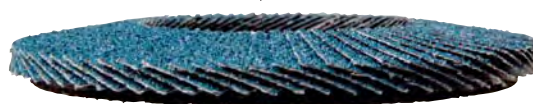

straight

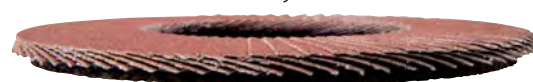

Flap discs normal corundum

G-A	perfect	Normal corundum	★★★★☆			
		<p>Reasonably priced product suitable for grinding steel and wood. Tough, hard abrasive grain permits good removal capacity, especially for surface work. The glass fibre backing is characterised by an even grinding finish until all of the abrasive grain has been worn away.</p> <p>Leaves no scratches on the workpiece.</p> <p>Packing unit: 10 pcs.</p> <ul style="list-style-type: none"> ▶ The best-seller with an excellent price/performance ratio. ▶ Good stock removal in a wide range of applications. 	<p>Steel, wood, aluminium</p>			
DIMENSION MM	DIMENSION INCH	SPEED R.P.M.	GRIT SIZE	SHAPE	ITEM-CODE	BAR CODE 4081600
115 x 22,23	4 1/2 x 7/8	13280	40	straight	5211004100	510508
115 x 22,23	4 1/2 x 7/8	13280	60	straight	5211006100	510515
115 x 22,23	4 1/2 x 7/8	13280	80	straight	5211007100	510522
115 x 22,23	4 1/2 x 7/8	13280	120	straight	5211009100	510546
115 x 22,23	4 1/2 x 7/8	13280	40	tapered	5211204100	510003
115 x 22,23	4 1/2 x 7/8	13280	60	tapered	5211206100	510010
115 x 22,23	4 1/2 x 7/8	13280	80	tapered	5211207100	510027
115 x 22,23	4 1/2 x 7/8	13280	120	tapered	5211209100	510041
125 x 22,23	5 x 7/8	12200	40	straight	5212004100	520507
125 x 22,23	5 x 7/8	12200	60	straight	5212006100	520514
125 x 22,23	5 x 7/8	12200	80	straight	5212007100	520521
125 x 22,23	5 x 7/8	12200	120	straight	5212009100	520545
125 x 22,23	5 x 7/8	12200	40	tapered	5212204100	521108
125 x 22,23	5 x 7/8	12200	60	tapered	5212206100	521115
125 x 22,23	5 x 7/8	12200	80	tapered	5212207100	521122
125 x 22,23	5 x 7/8	12200	120	tapered	5212209100	521146
180 x 22,23	7 x 7/8	8600	40	straight	5218004100	540505
180 x 22,23	7 x 7/8	8600	60	straight	5218006100	540512
180 x 22,23	7 x 7/8	8600	80	straight	5218007100	540529
180 x 22,23	7 x 7/8	8600	40	tapered	5218204100	542004
180 x 22,23	7 x 7/8	8600	60	tapered	5218206100	542011
180 x 22,23	7 x 7/8	8600	80	tapered	5218207100	542028



Flap discs zirconium corundum

G-AZ A

special

Zirconium corundum

★★★★☆

Mild steel, stainless steel, etc.



The support of the abrasive band consists of a cotton twill which shows an outstanding removing rate and excellent lifetime - without clogging up!

The glass fibre backing is characterised by an even grinding finish up to the complete consumption of the abrasive grain. As a result, no scratches on the workpiece will appear.

Packing unit: 10 pcs.

- ▶ Ideal for grinding surfaces of mild and stainless steel.
- ▶ Very good stock removal and effortless working without clogging.

DIMENSION MM	DIMENSION INCH	SPEED R.P.M.	GRIT SIZE	SHAPE	ITEM-CODE	BAR CODE 4081600
115 x 22,23	4 1/2 x 7/8	13280	40	straight	5211184100	511703
115 x 22,23	4 1/2 x 7/8	13280	60	straight	5211186100	511710
115 x 22,23	4 1/2 x 7/8	13280	80	straight	5211187100	511727
115 x 22,23	4 1/2 x 7/8	13280	120	straight	5211189100	511734
115 x 22,23	4 1/2 x 7/8	13280	40	tapered	5211384100	512809
115 x 22,23	4 1/2 x 7/8	13280	60	tapered	5211386100	512816
115 x 22,23	4 1/2 x 7/8	13280	80	tapered	5211387100	512823
115 x 22,23	4 1/2 x 7/8	13280	120	tapered	5211389100	512830
125 x 22,23	5 x 7/8	12200	40	straight	5212184100	521702
125 x 22,23	5 x 7/8	12200	60	straight	5212186100	521719
125 x 22,23	5 x 7/8	12200	80	straight	5212187100	521726
125 x 22,23	5 x 7/8	12200	120	straight	5212189100	521733
125 x 22,23	5 x 7/8	12200	40	tapered	5212384100	522808
125 x 22,23	5 x 7/8	12200	60	tapered	5212386100	522815
125 x 22,23	5 x 7/8	12200	80	tapered	5212387100	522822
125 x 22,23	5 x 7/8	12200	120	tapered	5212389100	522839
180 x 22,23	7 x 7/8	8600	40	straight	5218184100	541700
180 x 22,23	7 x 7/8	8600	60	straight	5218186100	541717
180 x 22,23	7 x 7/8	8600	40	tapered	5218384100	542806
180 x 22,23	7 x 7/8	8600	60	tapered	5218386100	542813
180 x 22,23	7 x 7/8	8600	80	tapered	5218387100	542820

K-AZ A

special

Zirconium corundum

★★★★☆

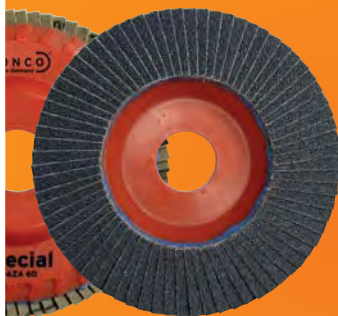

Flap disc with glass fibre reinforced plastic backing available in type "straight" only.

Newly developed zirconium abrasive cloth with outstanding material removal rate and service life. Does not leave any marks on the work piece.

Packaging unit: 10 pcs.

For surface and edge grinding.

- ▶ no scratches, no markings of the work piece
- ▶ newly developed abrasive cloth
- ▶ extremely tough reinforced plastic backing
- ▶ outstanding removal rate
- ▶ excellent lifetime
- ▶ can be used on the outer edge

DIMENSION MM	DIMENSION INCH	SPEED R.P.M.	GRIT SIZE	CONTENT PC	SHAPE	ITEM- CODE	BAR CODE 4081600
115 x 22,23	4 1/2 x 7/8	13280	40	10	straight	5111184100	514643
115 x 22,23	4 1/2 x 7/8	13280	60	10	straight	5111186100	514667
115 x 22,23	4 1/2 x 7/8	13280	80	10	straight	5111187100	514674
125 x 22,23	5 x 7/8	12200	40	10	straight	5112184100	524642
125 x 22,23	5 x 7/8	12200	60	10	straight	5112186100	524666
125 x 22,23	5 x 7/8	12200	80	10	straight	5112187100	524673



J-AZ A

special

Zirconium corundum

★★★★☆

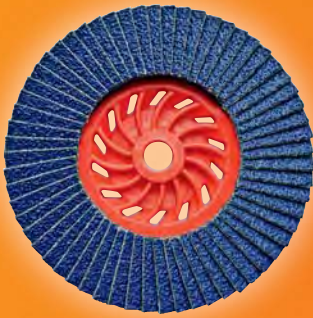

Top flap disc with glass fibre reinforced plastic backing. Equipped with zirconium abrasive on a cotton-polyester cloth. High stock removal and service life. Packing unit: 10 pcs.

| For steel and stainless steel.

- ▶ Quick to mount thanks to the integrated M 14 adaptor
- ▶ Air-cooled with cooling slots integrated in the backing
- ▶ Reinforced glass fibre plastic backing



JETzirkon

DIMENSION MM	DIMENSION INCH	SPEED R.P.M.	GRIT SIZE	CONTENT PC	SHAPE	ITEM-CODE	BAR CODE 4081600
115 x M14	4 1/2 x M14	13280	40	10	straight	5111154100	515206
115 x M14	4 1/2 x M14	13280	60	10	straight	5111156100	515213
115 x M14	4 1/2 x M14	13280	80	10	straight	5111157100	515220
115 x M14	4 1/2 x M14	13280	120	10	straight	5111159100	515237
125 x M14	5 x M14	12200	40	10	straight	5112154100	525205
125 x M14	5 x M14	12200	60	10	straight	5112156100	525212
125 x M14	5 x M14	12200	80	10	straight	5112157100	525229
125 x M14	5 x M14	12200	120	10	straight	5112159100	525236

G-AZ

special

Zirconium corundum



This abrasive grain is less hard, but very tough, and gives the disc very good all purpose characteristics. It is used for such demanding operations as deburring, machining welding seams and breaking edges. The glass fibre backing is characterised by an even grinding finish until all of the abrasive grain has been worn away. Leaves no scratches on the workpiece.

Packing unit: 10 pcs.

| Stainless steel, steel, cast, etc.

- ▶ Ideal for working on edges of mild or stainless steel.
- ▶ Brilliant grinding capacity with outstanding service life.

DIMENSION MM	DIMENSION INCH	SPEED R.P.M.	GRIT SIZE	SHAPE	ITEM-CODE	BAR CODE 4081600
115 x 22,23	4 1/2 x 7/8	13280	40	straight	5211104100	511505
115 x 22,23	4 1/2 x 7/8	13280	60	straight	5211106100	511512
115 x 22,23	4 1/2 x 7/8	13280	80	straight	5211107100	511529
115 x 22,23	4 1/2 x 7/8	13280	120	straight	5211109100	511543
115 x 22,23	4 1/2 x 7/8	13280	40	tapered	5211304100	511109
115 x 22,23	4 1/2 x 7/8	13280	60	tapered	5211306100	511116
115 x 22,23	4 1/2 x 7/8	13280	80	tapered	5211307100	511123
115 x 22,23	4 1/2 x 7/8	13280	120	tapered	5211309100	511147
125 x 22,23	5 x 7/8	12200	40	straight	5212104100	521504
125 x 22,23	5 x 7/8	12200	60	straight	5212106100	521511
125 x 22,23	5 x 7/8	12200	80	straight	5212107100	521528
125 x 22,23	5 x 7/8	12200	120	straight	5212109100	521542
125 x 22,23	5 x 7/8	12200	40	tapered	5212304100	521207
125 x 22,23	5 x 7/8	12200	60	tapered	5212306100	521214
125 x 22,23	5 x 7/8	12200	80	tapered	5212307100	521221
125 x 22,23	5 x 7/8	12200	120	tapered	5212309100	541052
180 x 22,23	7 x 7/8	8600	40	straight	5218104100	541502
180 x 22,23	7 x 7/8	8600	60	straight	5218106100	541519
180 x 22,23	7 x 7/8	8600	40	tapered	5218304100	541014
180 x 22,23	7 x 7/8	8600	60	tapered	5218306100	541021



G-AZ MAXX

evolution

Zirconium corundum



The G-AZ MAXX flap disc is a high-end product for all users who recognise quality. Its increased number of lamellas ensures an even more aggressive material removal rate (steeper arrangement of lamellas) and a much higher lifetime than the AZ type. Improved tried-and-trusted topquality to optimize the efficiency of your tool. G-AZ MAXX means: Less downtime, more efficient working. Packing unit: 10 pcs.

For mild steel and stainless steel. For grinding on edges as well as surfaces. Ideal for sheet metal working, tank construction, metal construction.

- ▶ Increased number of lamellas for MAXXimum removal rate.
- ▶ Distinctly increased lifetime compared to G-AZ.
- ▶ Optimise the efficiency of your tool.

DIMENSION MM	DIMENSION INCH	SPEED R.P.M.	GRIT SIZE	SHAPE	ITEM-CODE	BAR CODE 4081600
115x22,23	4 1/2 x 7/8	13.280	40	straight	5211134100	512557
115x22,23	4 1/2 x 7/8	13.280	60	straight	5211136100	512564
115x22,23	4 1/2 x 7/8	13.280	80	straight	5211137100	512571
115x22,23	4 1/2 x 7/8	13.280	40	tapered	5211294100	513257
115x22,23	4 1/2 x 7/8	13.280	60	tapered	5211296100	513264
115x22,23	4 1/2 x 7/8	13.280	80	tapered	5211297100	513271
125x22,23	5 x 7/8	12.200	40	straight	5212134100	521757
125x22,23	5 x 7/8	12.200	60	straight	5212136100	521764
125x22,23	5 x 7/8	12.200	80	straight	5212137100	521771
125x22,23	5 x 7/8	12.200	40	tapered	5212294100	522259
125x22,23	5 x 7/8	12.200	60	tapered	5212296100	522266
125x22,23	5 x 7/8	12.200	80	tapered	5212297100	522273

Flap discs ceramic grain

G-AK	evolution	Ceramic grain	★★★★			
	<p>An innovative new flap disc with self-sharpening ceramic grain, which guarantees a permanent and extremely high stock removal as well as a long service life. The ceramic grain on this innovative abrasive cloth is fixed on a robust polyester backing. Fully resinoid bonded with fillers for active grind support guarantees the abrasion resistance of the ceramic grain especially under high pressure. Outstanding results when grinding on surfaces as well as on edges on mild steel or stainless steel. Due to the high load capacity ideally suitable for extreme grinding applications or special tasks for steel, stainless steel, titanium-base alloy, nickel-based superalloy, chrome-steel and chromium-nickel steel, brass and bronze. Packing unit: 10 pcs.</p> <p>3 times better than zirconium:</p> <ul style="list-style-type: none"> ▶ Improved stock removal and effortless working ▶ Increased economic efficiency by noticeable time saving ▶ Improved service life ▶ Optimum Strength ▶ Self-sharpening ▶ Cool grinding on surfaces and edges 	<p>Sheet metal working, tank construction, cast iron, pipes and bars, metal constructions. Ideally suitable for steel, stainless steel, titanium-base alloy, nickel-based superalloy, chromesteel and chromium-nickel steel, brass and bronze.</p>	 			
DIMENSION MM	DIMENSION INCH	SPEED R.P.M.	GRIT SIZE	SHAPE	ITEM-CODE	BAR CODE 4081600
115 x 22,23	4 1/2 x 7/8	13280	40	straight	5211434100	512403
115 x 22,23	4 1/2 x 7/8	13280	60	straight	5211436100	512410
115 x 22,23	4 1/2 x 7/8	13280	80	straight	5211437100	512427
115 x 22,23	4 1/2 x 7/8	13280	40	tapered	5211444100	512434
115 x 22,23	4 1/2 x 7/8	13280	60	tapered	5211446100	512441
115 x 22,23	4 1/2 x 7/8	13280	80	tapered	5211447100	512458
125 x 22,23	5 x 7/8	12200	40	straight	5212434100	522402
125 x 22,23	5 x 7/8	12200	60	straight	5212436100	522419
125 x 22,23	5 x 7/8	12200	80	straight	5212437100	522426
125 x 22,23	5 x 7/8	12200	40	tapered	5212444100	522433
125 x 22,23	5 x 7/8	12200	60	tapered	5212446100	522440
125 x 22,23	5 x 7/8	12200	80	tapered	5212447100	522457



J-AK

evolution

Ceramic grain

★★★★



JETceramic

High-End Product: Flap disc with glass fibre reinforced plastic backing. Ceramic grain abrasive on polyester cloth. Fully resinoid bonded with fillers for active grind support. Self-sharpening ceramic grain for extremely high, permanently available stock removal as well as a long service life.

Packing unit: 10 pcs.

- ▶ Quick to mount thanks to the integrated M 14 adaptor
- ▶ Air-cooled with cooling slots integrated in the backing
- ▶ Reinforced glass fibre plastic backing

For the processing of steel and stainless steel, high-alloy steels, chrome and chrome nickel steel, titanium alloys, brass and bronze.



DIMENSION MM	DIMENSION INCH	SPEED R.P.M.	GRIT SIZE	CONTENT PC	SHAPE	ITEM- CODE	BAR CODE 4081600
115 x M14	4 1/2 x M14	13280	40	10	straight	5111424100	515305
115 x M14	4 1/2 x M14	13280	60	10	straight	5111426100	515312
115 x M14	4 1/2 x M14	13280	80	10	straight	5111427100	515329
125 x M14	5 x M14	12200	40	10	straight	5112424100	525304
125 x M14	5 x M14	12200	60	10	straight	5112426100	525311
125 x M14	5 x M14	12200	80	10	straight	5112427100	525328

Flap discs silicon carbide

G-C	perfect	Silicon carbide	★★★★			
 <p>Flap disc equipped with silicon carbide abrasive on a glass fibre backing. Good removal rate on various materials. Packing unit: 10 pcs.</p> <ul style="list-style-type: none"> ▶ Problem solver for working on aluminium and stone ▶ Good removal rate at universal use <p>For working on concrete, stone, tiles, ceramics, non-ferrous metals (aluminium, brass, copper), cast, plastics and fillers. Can be used for claw treatment as well.</p>						
DIMENSION MM	DIMENSION INCH	SPEED R.P.M.	GRIT SIZE	SHAPE	ITEM-CODE	BAR CODE 4081600
115 x 22,23	4 1/2 x 7/8	13280	40	tapered	5211404100	512045
115 x 22,23	4 1/2 x 7/8	13280	60	tapered	5211406100	512069
115 x 22,23	4 1/2 x 7/8	13280	80	tapered	5211407100	512076
125 x 22,23	5 x 7/8	12200	40	tapered	5212404100	522204
125 x 22,23	5 x 7/8	12200	60	tapered	5212406100	522211
125 x 22,23	5 x 7/8	12200	80	tapered	5212407100	522228

CLEANING- AND POLISHING TOOLS



With the right material to highest perfection. The DRONCO POLISHING FLAP DISC.

The DRONCO polishing flap disc delivers outstanding results through an innovative, highly effective grinding fleece arranged in a fan-shaped lamella structure. Especially adjusted for working on stainless steel, steel, aluminium, and non-ferrous metals.

Depending on the texture of the fleece, DRONCO polishing flap discs are perfectly suitable for

- ▶ Descaling and derusting work-pieces
- ▶ Preparing and repolishing welding seams
- ▶ Preparing surfaces for varnishing
- ▶ Polishing stainless steel
- ▶ Surface processing



Available in three textures in dimensions of 115mm and 125mm.

- **Highly effective for the use in welding technology and metalworking**
Optimum results e.g. during the preparation of welding seams, the finishing of welding seams and removal of welding spillage in accordance with EN ISO 5817. Removes oxide film/annealing colours after welding of pipes, containers and apparatus or after the plasma-arc cutting of stainless steel sheet metals in accordance with DIN 50930, DIN 25410, DVGW W541.
- **Highly effective for the use in painting technology**
Perfect to derust, removal of colours and prepare of painting surfaces.
- **Versatile usage**
Cleaning and polishing of unalloyed steel, high alloyed steel, aluminium and non-ferrous metal. Suitable for grinding on edges and surfaces.
- **High service life**



Polishing flap disc for angle-grinders

★★★★☆



Outstanding for descaling and derusting of stainless steel, steel, aluminium and non-ferrous metal. Preparation and finishing of welding seams. Preparing of painted surfaces, polishing of stainless steel. Packing unit: 10 pcs.

Polishing flap disc for the efficient processing of metals.

DESCRIPTION	DIMENSION MM	DIMENSION INCH	CONTENT PC.	ITEM CODE	BAR CODE 4081600
G-VA Coarse	115 x 22,23	4 1/2 x 7/8	coarse	5511204100	550047
G-VA Medium	115 x 22,23	4 1/2 x 7/8	medium	5511206100	550061
G-VA Fine	115 x 22,23	4 1/2 x 7/8	fine	5511207100	550078
G-VA Coarse	125 x 22,23	5 x 7/8	coarse	5512204100	551044
G-VA Medium	125 x 22,23	5 x 7/8	medium	5512206100	551068
G-VA Fine	125 x 22,23	5 x 7/8	fine	5512207100	551075

Polishing flap disc set including 54 pc. in our special offer box

★★★★☆



The innovative polishing flap discs in the attractive, self-explanatory special offer box. Contains 54 pc. with diameters of 115mm or 125mm. Optional also as mixed box including:
3 x 9 pc. 115mm (coarse, medium, fine) and
3 x 9 pc. 125mm (coarse, medium, fine)

Definitely a sales success - in the product shelf or on your sales counter.

DESCRIPTION	DIMENSION MM	DIMENSION INCH	CONTENT PC.	ITEM CODE	BAR CODE 4081600
Mixed box	115 / 125 mm	4 1/2 / 5	54	6900055100	700008

The innovation for polishing and cleaning The DRONCO POLISHING FLAP DISC



Grinding thin welding seams and removing thermal bluing



Professional derusting and descaling



Descaled surfaces prior to welding lead to clean welding seams

A multi-talented performer for corners and angles



- ▶ the soft fleece hugs the surface of the workpiece to perfection
- ▶ flexible application for corners, angles, U-profiles, on rounded or flat surfaces
- ▶ fast and simple removal of rust, cleaning and blank polishing of metals
- ▶ cleaning, smoothing and polishing welded seams for corners, angles and fillet welds
- ▶ removal of temper colour, oxide layers or thin layers of paint on metals
- ▶ suitable for stainless steel, steel, aluminium and nonferrous metals

The new polishing wheel gives a perfect shine to corners, angles, rounded and flat surfaces.

It combines the outstanding performance of the polishing flap disc with an added bonus. The new polishing wheel is ideal for cleaning difficult-to-reach areas effectively and polishing them to a fine finish.





Polishing wheel in an individual promotional pack

★★★★



Polishing wheel with upright flaps made from high performance non woven material with a reinforced plastic backing. This flexible material hugs the work piece to perfection. It can be used both on the edge in corners, angles and rounded edges as well as on its face for flat surfaces. Suitable for the removal of rust, cleaning and blank polishing of work pieces made from stainless steel, steel, aluminium and non-ferrous metals. Cleaning and polishing of welding seams in corners, angles or fillet welds. Removal of any discoloration, oxide layers and thin layers of paint.

DESCRIPTION	DIMENSION MM	DIMENSION INCH	STRUCTURE	CONTENT PC.	ITEM CODE	BAR CODE 4081600
P-WA Fine	115 x 22,23	4 1/2 x 7/8	fine	1	5511307102	700039
P-WA Medium	115 x 22,23	4 1/2 x 7/8	medium	1	5511306102	700046
P-WA Fine	125 x 22,23	5 x 7/8	fine	1	5512307102	700022
P-WA Medium	125 x 22,23	5 x 7/8	medium	1	5512306102	700015

Polishing wheel in Packing unit with 10 pc.

★★★★

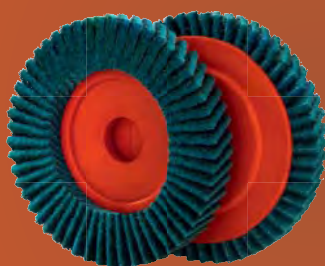

Our polishing wheel in practical box with 10 pc.

DESCRIPTION	DIMENSION MM	DIMENSION INCH	STRUCTURE	CONTENT PC.	ITEM CODE	BAR CODE 4081600
P-WA Fine	115 x 22,23	4 1/2 x 7/8	fine	10	5511307100	550207
P-WA Medium	115 x 22,23	4 1/2 x 7/8	medium	10	5511306100	550214
P-WA Fine	125 x 22,23	5 x 7/8	fine	10	5512307100	552072
P-WA Medium	125 x 22,23	5 x 7/8	medium	10	5512306100	552096

◀ Gloss polishing flap discs

Gloss Polishing flap disc for angle-grinders



The G-VA finish completes the programme of the DRONCO Polishing flap discs. The disc is equipped with flaps made of high-quality special felt and is generally used with polishing compounds. This gives the work piece a mirror finish.

Packing unit: 1 pc. or 10 pcs.

For polishing metals using polishing compounds.



DESCRIPTION	DIMENSION MM	DIMENSION INCH	STRUCTURE	CONTENT PC.	ITEM CODE	BAR CODE 4081600
G-VA Finish	115 x 22,23	4 1/2 x 7/8	felt	1 in Blister pack	5511221100	553123
G-VA Finish	125 x 22,23	5 x 7/8	felt	1 in Blister pack	5512221100	553130
Also available 10 pcs in Carton box						
G-VA Finish	115 x 22,23	4 1/2 x 7/8	felt	10	5511220100	553109
G-VA Finish	125 x 22,23	5 x 7/8	felt	10	5512220100	553116
Polishing set, 5-part for the processing of stainless steel	Blister pack, content: 1 x Polishing Flap Disc G-VA coarse. 1 x Polishing Flap Disc G-VA fine 1 x Gloss Polishing Flap Disc G-VA finish. 1 x Polishing compound blue, 110g, 1x Polishing compound white 110g					
G-VA Finish-Set	115 x 22,23	4 1/2 x 7/8	mixed	1 Set in Blister pack	6900040100	706208
G-VA Finish-Set	125 x 22,23	5 x 7/8	mixed	1 Set in Blister pack	6900041100	706215

Polishing compound, single, 110 Gram



Polishing compound white = pre-polishing steel and stainless steel.
Polishing compound brown = pre-polishing of non-ferrous metals
Polishing compound blue = gloss-polishing.

DESCRIPTION	DIMENSION GRAM	CONTENT PC.	ITEM CODE	BAR CODE 4081600
Polishing compound white	110	1	6400403000	707328
Polishing compound brown	110	1	6400402000	707311
Polishing compound blue	110	1	6400404000	707304

Recommended use:

- ▶ To start, process the work piece with the coarse G-VA Polishing flap disc followed by fine.
- ▶ The Gloss Polishing flap disc is always used with a corresponding polishing compound.
- ▶ Step 1: Start with a white or brown pre-polishing compound.
- ▶ Step 2: Use a new Polishing flap disc with a blue high-gloss polishing compound in order to obtain a high-gloss surface.
- ▶ For the polishing of aluminium and non-ferrous metals, use a brown polishing compound especially for these materials.
- ▶ With a reduced working speed of 4.500 rpm, better polishing results are achieved than with the angle grinder at full speed.



Brilliant results in 3 steps with our 10 pcs. Professional Polishing System

1

Pre-Polishing with Sisal cloth and polishing compound:

- ▶ white for stainless steel
- ▶ brown for non-ferrous metals
- ▶ most important step after grinding
- ▶ high stock removal



2

Polish with Notiflex® 914 in conjunction with polishing compound:

- ▶ white for stainless steel
- ▶ brown for non-ferrous metals
- ▶ hard cloth
- ▶ even surface

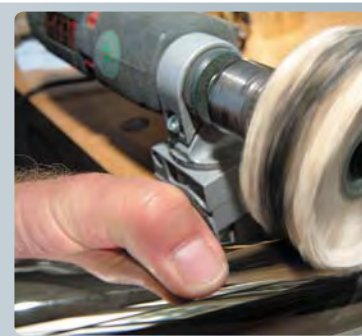

3

Mirror-finishing with Notiflex® 925 in conjunction with blue polishing compound

- ▶ short process time
- ▶ light contact pressure



Polishing System, 10 pcs.



For use on drilling machines, flexible shafts, angle polishers and stationary polishing stands for ultimate polishing in 3 steps.

Content of package:

- 6 Cloth discs: 2 x Sisal cloth, 2 x Notiflex® 914, 2 x Notiflex® 925
- 3 x polishing compound (white, brown, blue)
- 1 x drive arbor

Processing on pots, processing on mountings, automotive industry, builder's hardware

DESCRIPTION	DIMENSION MM	SPEED R.P.M.	ITEM- CODE	BAR CODE 4081600
Polishing System	100 mm	4000	6900003100	700688

PLEASE OBSERVE

Notiflex®: High quality randomly-placed fibre.

Advantages: no seams, little heating, 30 % less polishing compound use in relation to commercial polishing buffs. Not suitable for work on edges!

Coarse cleaning fleeces

Dronco cleaning fleeces produce optimum results when used to grind and rub down metal, stainless steel, wood or plastic surfaces and can be used as a preliminary stage before polishing. They are made of intertwined nylon fibres which are then immersed in synthetic resin and gently hardened. They are available with a glass fibre backing or for the use with straight or cylindrical grinders.

Coarse cleaning fleeces for the use on angle-grinders

★★★★☆



Suitable for cleaning and polishing all surfaces.
Packing Unit: 10 pc.

Removal of old paint, rust and welding splatter without scratching the surface of the work-piece, cleaning and smoothing wood and plastic, polishing of stainless steel and removal of thermal bluing.

DESCRIPTION	DIMENSION MM	DIMENSION INCH	SPEED R.P.M.	CONTENT PC.	ITEM CODE	BAR CODE 4081600
Cleaning fleece	115 x 22,23	4 1/2 x 7/8	11000	10	6700001100	670059
Cleaning fleece	125 x 22,23	5 x 7/8	10000	10	6700002100	670103
Cleaning fleece	180 x 22,23	7 x 7/8	8500	10	6700003100	670158

Coarse cleaning fleece set including 36 pc. in our special offer box

★★★★☆



Our coarse cleaning fleece in the attractive, self-explanatory special offer box. Mixed box contains 18 pc. 115mm, and 18 pc. 125mm with fibre backing.

Definitely a sales success - in the product shelf or on your sales counter.

DESCRIPTION	DIMENSION MM	DIMENSION INCH	CONTENT PC.	ITEM CODE	BAR CODE 4081600
Mixed box	115 / 125 x 22,23	4 1/2 / 5 x 7/8	2 x 18	6700012100	683349

PLEASE NOTE

This product is also suitable for battery-powered angle grinders in diameters 115 and 125 mm.





PLEASE OBSERVE

Coarse cleaning fleeces are designed to be used flat - they are not suitable for grinding or cutting.

Coarse cleaning fleeces for straight and cylindrical grinders

★★★★☆

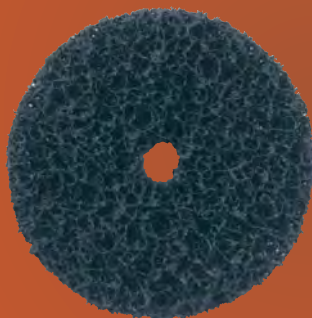

Suitable for cleaning and polishing all surfaces. The use on straight or cylindrical grinders happens with a tensioning shaft.

Removal of old paint, rust and welding splatter without scratching the surface of the work-piece, cleaning and smoothing wood and plastic, polishing of stainless steel and removal of thermal bluing.

DESCRIPTION	DIMENSION MM	DIMENSION INCH	CONTENT PC.	ITEM CODE	BAR CODE 4081600
Cleaning fleece	100 mm	4	10	6700006000	670301
Cleaning fleece	150 mm	6	10	6700007000	670356

Tensioning shaft



The tensioning shaft enables the use of cleaning fleeces on straight or cylindrical grinders.

DESCRIPTION	DIMENSION MM	DIMENSION INCH	CONTENT PC.	ITEM CODE	BAR CODE 4081600
Tensioning shaft	6 mm		1	6700008100	670400

More grinding luxury for your customers

The coarse cleaning fleece with best results during test



For better depiction, the guard of the angle-grinder was removed for picture taking.

Please make sure to use the coarse cleaning fleece on your angle-grinder with appropriate safety precautions only.



The Label - briefly explained

The label of the diamond blade contains all important information about the product.

1 Description

Consists of the purpose and performance class (3 / 4 / 5 / 7): e.g. U5

U – Universal

S – Stone Plates

F – Tiles or Stoneware

B – Concrete

G – Granite and Hard Stones

A – Abrasive Stones and Asphalt

AM – Mortar Raking

2 Product Lines

perfect | superior | evolution | xtreme
More details on page 91.

3 Safety Standards

Our products comply with the highest standards and regulations:

EN 13 236 - diamond tools

OSHA - The Organization for the Safety of Abrasives

4 Dimensions

Consist of [diameter of the blade]

x [thickness of the segments]

x [bore size].

Dimensions given in mm.

5 max. RPM

Indicates the permitted maximum speed.

In this example 6600 rpm.

6 Directional Arrow

Indicates the direction of rotation of the blade.

7 Red Bar

Indicates 80 m/s as permitted peripheral speed.

Green Bar

Indicates 100 m/s as permitted peripheral speed.

8 Safety Information

For your own safety. Please observe!

9 www.dronco.com

24 hour service on our website - we are always there when you need us!





THE RIGHT TOOL
FOR EVERY TASK

DIAMOND
CUTTING DISCS

S3 turbo STEEL

U4 speed

B5

U7 speed

UNIVERSAL BAUMATERIAL

XTREME

DRONCO
www.dronco.com

DRONCO GmbH
D-99632 Wunsiedel
Mikronstraße 1

max. RPM 6600
max. 80m/s

Ø 230 mm
⊙ 22,23 mm

Art. 423135190
LASER

CONSTRUCTION SITE MATERIALS | MATERIAUX DE CHANTIER
MATERIAL DE OBRAS | MATERIALE DA CANTIERE

HIGH SPEED LONG LIFE

Many years of experience for best quality

Diamond tools have been part of our range for more than 30 years. During this period an in-depth knowledge has been achieved, which our customers benefit from.



Innovation

Always one step ahead

Our R+D team is working in modern laboratories on future-oriented technologies for abrasive tools, resulting in product innovations and a continuous improvement of existing products with regard to cutting ability, lifetime, speed and precision. As a result, significant performance improvements of more than 30 % in the sector of diamond tools have been achieved in the past few years.



Diamonds

DRONCO relies on synthetic diamonds

The diamonds are responsible for the actual cutting work of the tool. DRONCO uses synthetic diamonds which have the same degree of hardness as natural diamonds. In comparison to their natural counterparts, they offer the advantage of an ideal structure that always remains the same. Both grain size and the crystalline shape of the diamonds are adjusted to the optimum parameters for the respective field of application in order to achieve perfect cutting abilities and a high lifetime.



Highest Safety Standards

In terms of safety and quality, DRONCO diamond cutting blades are manufactured and tested according to the latest standards, regulations and norms. Our quality management system ensures that we meet the high demands of a modern, worldwide acting industrial enterprise on all levels. Certification in accordance to DIN EN ISO 9001:2008 is therefore just as normal as our oSa membership (Organization for the Safety of Abrasives).

Tested Safety According to EN 13 236 and oSa

EN 13 236

European safety standard for diamond tools

oSa

The Organization for the Safety of Abrasives



OUR PRODUCTS SAFETY FIRST!

Being a member of oSa, we do everything to make our abrasive tools as secure as possible.

Core Geometry

Introducing the various core shapes used for our diamond cutting blades.

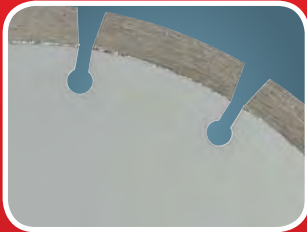

Standard Segmentation (C3)

- narrow gullet
- small slots with slot holes

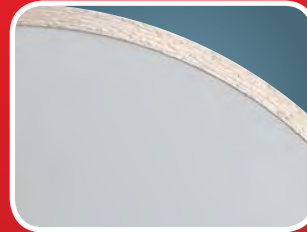

Continuous Rim (GRF)

- stable running
- cutting edges without chipping

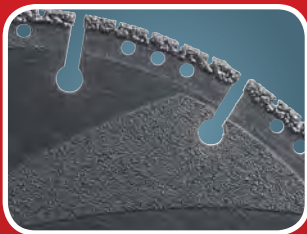

Standard Segmentation Diamond Brazed

- small slots with slot holes
- segments directly coated with diamonds in a vacuum-process
- good discharge of material

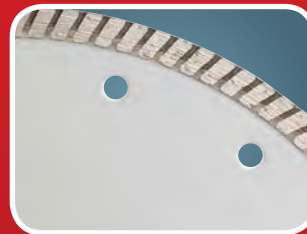

Continuous Turbo Rim

- stable running
- clean cut without chipping



Turbo Segmentation (C3)

- small slots with slot holes
- aggressive fast cut
- higher lifetime

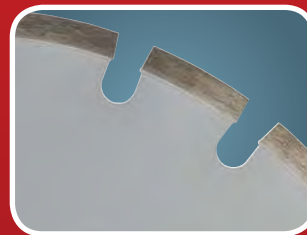

Wide Segmentation (C1)

- normal gullet
- wide slots
- good discharge of material



Speed Segmentation (C3)

- narrow gullet
- small slots with slot holes
- aggressive fast cut
- outstanding lifetime, no cooling breaks
- suitable for cutting metal

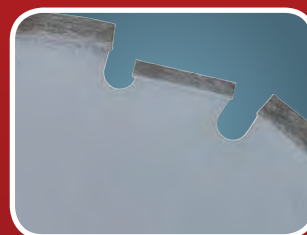

Wide Segmentation with Core Guard Segments (C1S)

- normal gullet
- wide slots
- good discharge of material
- core guard segments to protect the core as well as to prevent undercutting

VIBRATION AND NOISE CAN BE REDUCED EFFECTIVELY

Our "Protect" blades are using special sandwich steel cores which are reducing vibration and noise noticeably during the cutting operations.



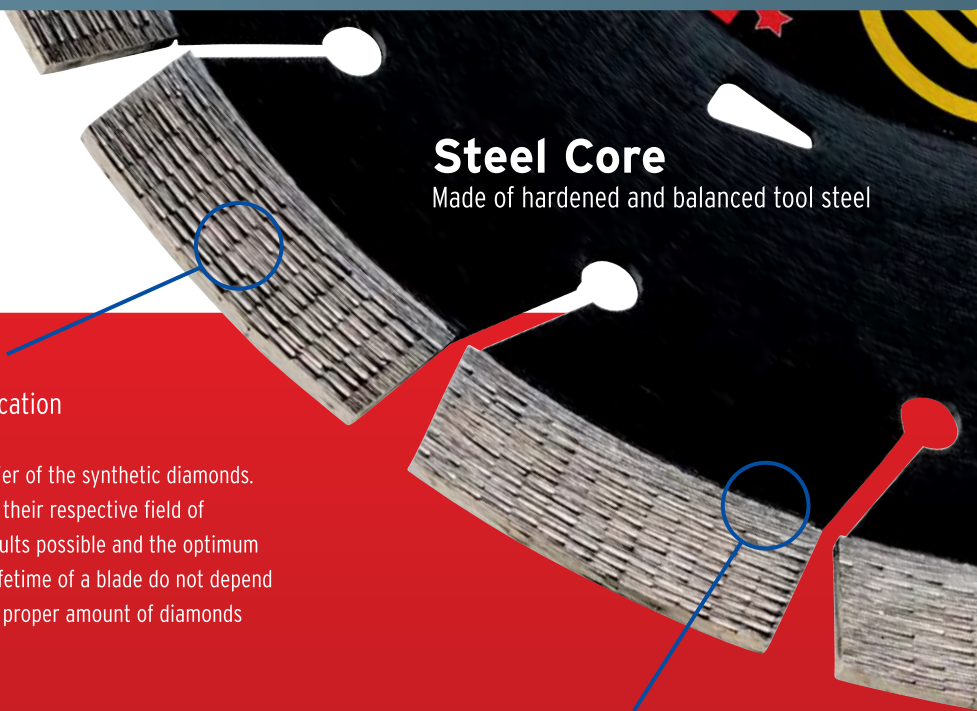

Steel Core

Made of hardened and balanced tool steel

Diamond Segment

The ideal material for all fields of application

The bond of the individual segments is the carrier of the synthetic diamonds. The high-tech bonds are specifically adapted to their respective field of application in order to ensure both the best results possible and the optimum wear of the bonds. The cutting ability and the lifetime of a blade do not depend on the highest concentration, but rather on the proper amount of diamonds and the composition of the bond:

Hard Material → Soft Bond

Soft Material → Hard Bond



Poor - excessive wear of the bond

The diamond grain separates prematurely, resulting in a shortened lifetime.



Poor - insufficient wear of the bond

The diamond grain is polished or broken off on the bond level. New diamonds cannot be released and the blade loses its cutting ability.

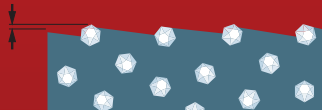

Perfect - optimum wear of the bond

The diamond grain is evenly released. The blade maintains its cutting ability and achieves an ideal lifetime. The trail of the bond perfectly supports the diamond grain and ensures an optimum cutting ability.

Segment Bond

Joins the steel core and the segment

There are two methods for permanently joining the diamond segments and the steel core:

Laser welding

This method is characterized by the fact that the diamond segments are permanently welded to the high-quality steel core. As segment losses can almost be completely excluded, this method ensures the best operational safety possible.

Sintering

During this process, the segments are sintered to the steel core by applying high pressure and temperature.



DRY CUTTING BLADES

DRONCO diamond cutting blades for dry cutting can be used for wet cutting as well without any concern.



WET CUTTING BLADES

DRONCO diamond cutting blades for wet cutting may only be used on water-cooled machines!

Strong content - Strong outfit

We think a top product needs an appealing packaging. That's why DRONCO does not use a random solution, but a carefully thought out, eye-catching outfit to inform and convince our customers visually and haptically.

The outstanding product quality and high-class brand image will help to showcase you as a distributor as well. Our self-explanatory packaging facilitates the consulting of your customers and therefore improves the sales.

Completely Protected

The carton sleeve with closed sides protects the product ideally.

Colour Coding System

Six colours ensure a quick orientation. Read more on page 92.

QR Code

Learn more about the product by scanning the QR code on the packaging.

Clear View on the Product

Most of the steel core and the diamond segments are visible.

Clear Information

All relevant information on the product as well as the packaging are easy to comprehend. Multilingual recommendations of application can be found on the reverse of the packaging (16 languages).

Concise Description

The product name consists of purpose, product line and additional features.

Illustrated Application

Recognize the field of application at a glance.

The Segment Check

"Feel the Power". The cut out packaging allows you to "feel" the diamond segments.



DIAMOND CUTTING DISCS



Our Product lines - For all demands

Three quality lines based on the good-better-best-principle: From the solid craftsmen quality, which is used by semi-professionals as well, to the absolute high-end tools for the intensive use on construction sites; DRONCO has the right tool for all demands.

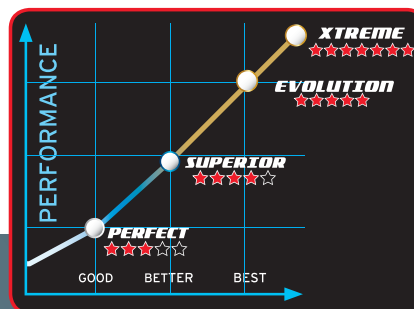

BEST



High performance diamond cutting blades for the professional user to meet high expectation on demanding application. Maximum cutting speed and outstanding lifetime. Wide range of application. The Evolution and Xtreme line can be recognized by their gold labels and 5 or 7 stars.



BETTER



Premium tools for the professional user. Effective, durable and economical. Convincing in daily use thanks to their fast cutting speed and good lifetime. Outstanding price-performance ratio. The Superior line can be recognized by its blue label and 4 stars.



GOOD



The economically priced assortment for many different tasks in approved craftsmen quality. Good lifetime and fast cutting speed at an attractive price. For users who place the emphasis on quality but don't need a high-performance tool for continuous use. The Perfect line can be recognized by its silver label and 3 stars.

DIAMOND CUTTING DISCS

The right cutting blade found instantly

Our colour coding system on the packaging of the diamond cutting blades features six distinctive colours, each for a different field of application. Additionally the materials which the blades are suitable for are illustrated on the carton sleeves. Thanks to the detailed application chart, you can easily determine which diamond cutting blade is the best choice for your field of application.

COLOUR CODING SYSTEM:

Universal
Yellow



Concrete
Green



Tiles/Stoneware
Turquoise



DO YOU NORMALLY CUT THE SAME OR DIFFERENT TYPES OF MATERIAL?

Same material

We recommend using the following blades:

A4, B4, B5 and G4

Different materials

For applications with a wide range of materials we recommend using the following blades:

U3, U4, U4 speed, U4 protect, DB4, U5 speed, U5 protect and U7 speed



Stone Plates

Orange



Granite and Hard Stones

Navy Blue



Abrasive Stones and Asphalt

Red



WHEN SHOULD YOU USE A BLADE WITH A CONTINUOUS RIM?

If you want to cut materials where a clean cut is required (e.g. tiles, glazed bricks, stoneware), we recommend you to use one of the following blades:
S3 turbo, S5 turbo, S5 turbo protect, F3, F4 cera and F5 cera speed

The continuous rim prevents the edges from chipping, guaranteeing a brilliant cutting result. Blades with a continuous rim should only be used up to a cutting depth of 2 cm when cutting dry.

Application chart of diamond cutting blades		PAGE	Asphalt	Basalt	Reinforced wire mesh	Concrete	Concrete, reinforced	Concrete roofing tiles	Composite concrete paving	Cotto plates	Ductile and Cast pipes	Skreed, floor pavement, plaster	Eternit	Fine stoneware, Quarry tiles	Refractory stones	Tiles	Green concrete
<ul style="list-style-type: none"> ●●● most suitable ●● very suitable ● suitable ○ limited suitable 																	
UNIVERSAL / CONSTRUCTION SITE MATERIALS																	
ST-7	QUALITY	96				●		●									
U3	PERFECT	96				●		●									
U4	SUPERIOR	97		●		●●	●	●	●	●		●					
U4 SPEED	SUPERIOR	97		●●	●●	●●	●●	●●	●●	●●	●	●	●●				
DB4	SUPERIOR	98		●●	●●	●●	●●	●●	●●	●●	●●	●	●●				
U4 PROTECT	SUPERIOR	98		●●	●●	●●	●●	●●	●●	●●	●	●	●●				
U5 SPEED	EVOLUTION	99	●	●●	●●	●●●	●●●	●●●	●●●	●●	●●●	●	●●		●●		
U5 PROTECT	EVOLUTION	100	●	●●	●●	●●●	●●●	●●●	●●●	●●	●●●	●	●●		●		
U7 SPEED	XTREME	101	●	●●	●●	●●●	●●●	●●●	●●●	●●	●●●	●	●●		●●		
STONE PLATES / ROOF TILES																	
S3 TURBO	PERFECT	102				●		●●		●				○		●	
S5 TURBO PROTECT	EVOLUTION	102				●●		●●●		●●●				●	○	●	
S5 TURBO	EVOLUTION	103				●●		●●●		●●●				●	○	●	
TILES / STONEWARE																	
F3	PERFECT	103								●						●●	
F4 CERA	SUPERIOR	104				●		●		●●●				●●●		●●●	
F5 CERA SPEED	SUPERIOR	105				●		●		●●●				●●●		●●●	
CONCRETE																	
B4	SUPERIOR	106				●●	●●	●●	●●	●		●	●●				
B5	EVOLUTION	107	○	●●		●●●	●●●	●●●	●●●	●●●	●●	●	●●●		●		
GRANITE / HARD STONES																	
G4	SUPERIOR	108		●●●		●		●		●●					●		
ABRASIVE STONES / ASPHALT																	
A4	SUPERIOR	108	●●●					●				●●●	●		○		●●
A4 ASPHALT	SUPERIOR	109	●●●					●				●●●	●		○		●●
A4 M	SUPERIOR	109				●						●●	●				

In the application chart you will find the diamond blades pre-sorted according the field of application. You can see which disc is most suitable for different material.

On which type of machine can the blades be used?

These information can also be found in the descriptions of each type on the following pages.

Bore 22.23 mm for angle grinders

Bore 25.4 mm or 30 mm for table saws

Bore 20 mm or 22.23 mm or 25.4 mm for petrol saws

DIAMOND CUTTING DISCS



Application chart of diamond cutting blades		Porous concrete	Gneiss	Granite	Cast up to 5 mm	Sand-lime stone	Limestone	Clinker, Engineering bricks	Marble	Paver	Porphyry	Sandstone	Slate	Steel up to 3,5 mm	Terrazzo	Exposed aggregate concrete	Bricks	
UNIVERSAL / CONSTRUCTION SITE MATERIALS																		
ST-7	QUALITY	●				●	●					●					●	
U3	PERFECT	●				●	●					●					●	
U4	SUPERIOR	●	●	●		●	●				●	●	●		●	●	●	
U4 SPEED	SUPERIOR	●	●	●		●	●	●		●	●	●	●	●	●	●	●	
DB4	SUPERIOR	●	●	●	●	●	●	●	●	●	●	●	●	●	●	●	●	
U4 PROTECT	SUPERIOR	●	●	●		●	●	●		●	●	●	●	●	●	●	●	
U5 SPEED	EVOLUTION	●●	●●	●●		●●	●●	●●	●	●●	●●	●	●	●●	●●	●●	●●	
U5 PROTECT	EVOLUTION	●●	●●	●●		●●	●●	●●	●	●●	●●	●	●	●●	●●	●●	●●	
U7 SPEED	XTREME	●●	●●	●●		●●	●●	●●	●	●●	●●	●	●	●●	●●	●●	●●	
STONE PLATES / ROOF TILES																		
S3 TURBO	PERFECT		●	●		●	●	●	●		●	●	●		●	●	●	
S5 TURBO PROTECT	EVOLUTION		●●	●●		●	●	●	●		●	●	●		●●	●	●●	
S5 TURBO	EVOLUTION		●●	●●		●	●	●	●		●	●	●		●●	●	●●	
TILES / STONWARE																		
F3	PERFECT																	
F4 CERA	SUPERIOR		●	●							●				●			
F5 CERA SPEED	SUPERIOR		●●	●●							●				●●			
CONCRETE																		
B4	SUPERIOR	●					●	●		●					●●	●●	●●	
B5	EVOLUTION	●●	●	●		●●	●●	●●		●●	●●	●	●●		●●	●●	●●	
GRANITE / HARD STONES																		
G4	SUPERIOR		●●●	●●●		●	●●	●●	●●	●	●●	●	●●		●●	●		
ABRASIVE STONES / ASPHALT																		
A4	SUPERIOR	●●				●●●						●●●					●●	
A4 ASPHALT	SUPERIOR	●●				●●●						●●●					●●	
A4 M	SUPERIOR	●●				●●						●					●●	

DIAMOND CUTTING DISCS

You can get DRONCO Diamond cutting discs in different performance classes - from a standard product for occasional use up to the high-end product for professional applications. On the following pages you will always find the corresponding symbol for the respective performance class of the tools in the heading of each type.



PROFESSIONAL APPLICATION

High-end product: extremely fast cutting, outstanding lifetime, minimum effort



DEMANDING APPLICATION

Very good cutting performance, high lifetime



STANDARD APPLICATION

Good cutting performance, good service life

Universal | Construction site materials

ST-7 **quality** **Dry and wet cutting** ★☆☆☆



Sintered, segmented diamond cutting disc.
All-round diamond cutting disc at a fair price.
Packing unit: 1 pc.

| All kind of construction site material





DIMENSION MM	DIMENSION INCH	SPEED R.P.M.	NUMBER OF SEGMENTS	HEIGHT OF SEGMENTS IN MM	SHAPE	ITEM CODE	BAR CODE 4081600
115 x 2 x 22,23	4 1/2 x 5/64 x 7/8	13280	9	7	C 3	4110485100	412406
125 x 2 x 22,23	5 x 5/64 x 7/8	12200	9	7	C 3	4120485100	422405
180 x 2,2 x 22,23	7 x 3/32 x 7/8	8600	14	7	C 3	4180485100	442403
230 x 2,4 x 22,23	9 x 3/32 x 7/8	6600	18	7	C 3	4230485100	452402

U3 **perfect** **Dry and wet cutting** ★★★★★



Sintered, segmented diamond cutting blade designed to cut construction site materials with a good price-performance ratio.
Packing unit: 1 pc.

| All kinds of construction site materials, e.g. concrete, exposed aggregate concrete, bricks.

DIMENSION MM	DIMENSION INCH	SPEED R.P.M.	NUMBER OF SEGMENTS	HEIGHT OF SEGMENTS IN MM	SHAPE	ITEM CODE	BAR CODE 4081600
115 x 2 x 22,23	4,5 x 5/64 x 7/8	13280	8	10	C3	4113810100	040012
125 x 2 x 22,23	5 x 5/64 x 7/8	12200	9	10	C3	4123810100	040029
180 x 2,4 x 22,23	7 x 3/32 x 7/8	8600	13	10	C3	4183810100	040036
230 x 2,5 x 22,23	9 x 3/32 x 7/8	6600	16	10	C3	4233810100	040043
300 x 3 x 20	12 x 7/64 x 3/4	6400	22	10	C3	4303805100	040050
300 x 3 x 22,23	12 x 7/64 x 7/8	6400	22	10	C3	4303810100	040067
300 x 3 x 25,4	12 x 7/64 x 1	6400	22	10	C3	4303815100	040074
350 x 3,2 x 25,4	14 x 7/64 x 1	5500	20	10	C3	4353815100	040081

DIAMOND CUTTING DISCS



U4

superior

Dry and wet cutting

★★★★☆



Laser welded, segmented blade designed to cut construction site materials dry or wet. Maximum safety and very good cutting results at a reasonable price.
Packing unit: 1 pc.

Construction site materials, e.g. concrete, exposed aggregate concrete, border stones.



DIMENSION MM	DIMENSION INCH	SPEED R.P.M.	NUMBER OF SEGMENTS	HEIGHT OF SEGMENTS IN MM	SHAPE	ITEM CODE	BAR CODE 4081600
115 x 2,2 x 22,23	4,5 x 3/32 x 7/8	13280	9	10	C3	4114185100	040098
125 x 2,2 x 22,23	5 x 3/32 x 7/8	12200	10	10	C3	4124185100	040104
150 x 2,4 x 22,23	6 x 3/32 x 7/8	10200	12	10	C3	4154185100	040111
180 x 2,4 x 22,23	7 x 3/32 x 7/8	8600	14	10	C3	4184185100	040128
230 x 2,4 x 22,23	9 x 3/32 x 7/8	6600	16	10	C3	4234185100	040135
300 x 2,8 x 20	12 x 7/64 x 3/4	6400	16	10	C3	4304180100	040142
300 x 2,8 x 22,23	12 x 7/64 x 7/8	6400	16	10	C3	4304182100	040159
300 x 2,8 x 25,4	12 x 7/64 x 1	6400	16	10	C3	4304190100	040166
300 x 2,8 x 30	12 x 7/64 x 1 1/5	6400	16	10	C3	4304192100	041491
350 x 2,8 x 20	14 x 7/64 x 3/4	5500	19	10	C3	4354180100	040173
350 x 2,8 x 22,23	14 x 7/64 x 7/8	5500	19	10	C3	4354185100	040180
350 x 2,8 x 25,4	14 x 7/64 x 1	5500	19	10	C3	4354190100	040197
350 x 2,8 x 30	14 x 7/64 x 1 1/5	5500	19	10	C3	4354195100	040203
400 x 3,2 x 25,4	16 x 7/64 x 1	4780	28	10	C3	4404190100	040210
450 x 3,6 x 25,4	18 x 1/8 x 1	4250	32	10	C3	4454190100	040227

U4 speed

superior

Dry and wet cutting

★★★★☆



Laser-welded universal diamond blade with a wide field of application. Special speed-slot segments allow high cutting speed and good all-round performance at an attractive price. The punched steel core ensures a smooth operation with optimum cooling. Outstanding price-performance ratio.
Packing unit: 1 pc.

For concrete, reinforced concrete, natural stone and construction site materials



DIMENSION MM	DIMENSION INCH	SPEED R.P.M.	NUMBER OF SEGMENTS	HEIGHT OF SEGMENTS IN MM	SHAPE	ITEM CODE	BAR CODE 4081600
115 x 2,2 x 22,23	4,5 x 3/32 x 7/8	13280	9	10	C3	4114521100	040234
125 x 2,2 x 22,23	5 x 3/32 x 7/8	12200	10	10	C3	4124521100	040241
180 x 2,4 x 22,23	7 x 3/32 x 7/8	8600	14	10	C3	4184521100	040258
230 x 2,6 x 22,23	9 x 7/64 x 7/8	6600	15	10	C3	4234521100	040265
300 x 3 x 20	12 x 7/64 x 3/4	6400	20	10	C3	4304521100	040272
300 x 3 x 25,4	12 x 7/64 x 1	6400	20	10	C3	4304525100	040289
350 x 3 x 25,4	14 x 7/64 x 1	5500	23	10	C3	4354525100	040296

DB4 superior Dry and wet cutting ★★★★★



The all-round product with a voracious appetite for cutting - for universal use in a broad range of applications on construction sites or by emergency services. The steel blade is directly coated with diamonds in a special vacuum process.
Packing unit: 1 pc.

Very good cutting abilities in many materials such as artificial and natural stone: concrete, reinforced concrete, exposed aggregate concrete, concrete paving, Indian granite, quarry slabs, granite slabs, sandlime stone, bricks. Metals: iron constructions and iron profiles, cast iron, sheet metals, non-ferrous metals, ductile pipes. Plastics, fibreglass, carbon fibre, wood, rubber, etc.



DIMENSION MM	DIMENSION INCH	SPEED R.P.M.	NUMBER OF SEGMENTS	HEIGHT OF SEGMENTS IN MM	SHAPE	ITEM CODE	BAR CODE 4081600
115 x 2,4 x 22,23	4,5 x 3/32 x 7/8	13280	9	6	C3	4114208100	040302
125 x 2,4 x 22,23	5 x 3/32 x 7/8	12200	10	6	C3	4124208100	040319
180 x 2,6 x 22,23	7 x 7/64 x 7/8	8600	14	7	C3	4184208100	040326
230 x 2,6 x 22,23	9 x 7/64 x 7/8	6600	16	8	C3	4234208100	040333
300 x 3 x 20	12 x 7/64 x 3/4	6400	20	8	C3	4304207100	040340
350 x 3,4 x 20	14 x 1/8 x 3/4	5500	24	8	C3	4354207100	040357

U4 protect superior Dry and wet cutting ★★★★★



The laser welded universal diamond cutting blade with noise reducing sandwich core combines best working practice with an excellent cutting performance and a reasonable price.
Packing unit: 1 pc.

All-round product for concrete, reinforced concrete, natural stone and construction site materials

- ▶ reduces noise and vibration*
- ▶ excellent cutting speed
- ▶ high lifetime thanks to its 10 mm segments



DIMENSION MM	DIMENSION INCH	SPEED R.P.M.	NUMBER OF SEGMENTS	HEIGHT OF SEGMENTS IN MM	SHAPE	ITEM CODE	BAR CODE 4081600
115 x 2,2 x 22,23	4,5 x 3/32 x 7/8	13280	9	10	C3	4114234100	040364
125 x 2,2 x 22,23	5 x 3/32 x 7/8	12200	10	10	C3	4124234100	040371
230 x 2,6 x 22,23	9 x 7/64 x 7/8	6600	16	10	C3	4234234100	040388
300 x 2,8 x 20	12 x 7/64 x 3/4	6400	20	10	C3	4304232100	040395
300 x 2,8 x 22,23	12 x 7/64 x 7/8	6400	20	10	C3	4304234100	040401
300 x 2,8 x 25,4	12 x 7/64 x 1	6400	20	10	C3	4304236100	040418

*U4 protect - 8 db (A), dimension 230 mm, in comparison to a U4 diamond blade

DIAMOND CUTTING DISCS



U5 speed

evolution

Dry and wet cutting

★★★★★



Our bestseller: Laser welded all-round cutting blade with speed segments for an ultimately fast cutting speed and clean cutting edges. Excellent universality, outstanding lifetime. Can be used for soft, abrasive stones as well as hard natural stones. No cooling brakes needed. Packing unit: 1 pc.

Top class all-round product!

- ▶ aggressive laser welded speed segments
- ▶ high-performance diamonds
- ▶ no cooling brakes
- ▶ outstanding cutting speed
- ▶ extremely high lifetime

All kind of construction site materials, e.g. basalt, concrete, reinforced concrete, cotto, ductile and cast pipes, gneiss, granite, clinker bricks, porphyry, exposed aggregate concrete, bricks, etc.



DIMENSION MM	DIMENSION INCH	SPEED R.P.M.	NUMBER OF SEGMENTS	HEIGHT OF SEGMENTS IN MM	SHAPE	ITEM CODE	BAR CODE 4081600
115 x 2,2 x 22,23	4,5 x 3/32 x 7/8	13280	8	12	C3	4115386100	040654
125 x 2,2 x 22,23	5 x 3/32 x 7/8	12200	9	12	C3	4125386100	040661
180 x 2,4 x 22,23	7 x 3/32 x 7/8	8600	12	12	C3	4185386100	040678
230 x 2,6 x 22,23	9 x 7/64 x 7/8	6600	16	15	C3	4235386100	040685
300 x 3,2 x 20	12 x 7/64 x 3/4	6400	21	15	C3	4305657100	040692
300 x 3,2 x 25,4	12 x 7/64 x 1	6400	21	15	C3	4305667100	040708
350 x 3,2 x 20	14 x 7/64 x 3/4	5500	25	15	C3	4355657100	040715
350 x 3,2 x 22,23	14 x 7/64 x 7/8	5500	25	15	C3	4355662100	040722
350 x 3,2 x 25,4	14 x 7/64 x 1	5500	25	15	C3	4355667100	040739

U5 protect

evolution

Dry and wet cutting



Laser welded all-round diamond disc with a special sandwich steel core, which reduces vibration noticeably and noise by 50 %. The segments are made of high performance diamonds and a bonding designed for extremely high cutting speeds. Clean cutting properties and a very good lifetime are also features of this product. The field of applications ranges from hard to soft materials, abrasive materials, as well as reinforced materials. The disc can be used without cooling brakes. Packing unit: 1 pc.

All kind of construction site materials, e.g. concrete, reinforced concrete, exposed aggregate concrete. Usable for hard stones, gneiss, granite, clinker bricks, porphyry, bricks, ductile and cast pipes etc.



Do you know the latest legal regulations based on the EU guidelines for protecting workers from noise and vibration? The U5 protect allows responsible employers to provide their staff with tools, which significantly reduce health damaging factors in the work environment. A reduction in noise level by minus 10 db(A) = halving the volume. The U5 protect features an extraordinary high-tech steel core, which reduces the sound level by 50 %. This also makes the experience of the cutting procedure around the construction site much more pleasant. Another bonus for the operator is the noticeably lower vibration level. These two factors add up to important protection for the health of the operator. And this is achieved with no loss in performance. The U5 protect offers outstanding cutting speed and the lower vibration level also reduces wear and tear on the segments - increasing the lifetime of the product.

50% less noise, noticeable less vibration

- ▶ high-performance diamonds for outstanding cutting speed
- ▶ excellent lifetime
- ▶ no cooling brakes
- ▶ noise and vibration reduced

DIMENSION MM	DIMENSION INCH	SPEED R.P.M.	NUMBER OF SEGMENTS	HEIGHT OF SEGMENTS IN MM	SHAPE	ITEM CODE	BAR CODE 4081600
230 x 2,8 x 22,23	9 x 7/64 x 7/8	6600	16	10	C3	4235613100	040746
300 x 2,8 x 20	12 x 7/64 x 3/4	6400	20	12	C3	4305603100	040753
300 x 2,8 x 25,4	12 x 7/64 x 1	6400	20	12	C3	4305624100	040760
350 x 2,8 x 20	14 x 7/64 x 3/4	5500	24	12	C3	4355603100	040777
350 x 2,8 x 25,4	14 x 7/64 x 1	5500	24	12	C3	4355624100	040784

DIAMOND CUTTING DISCS



U7 speed

xtreme

Dry and wet cutting

★★★★★★



The special, geometrically arranged diamonds within the segments of the ultra fast and indestructible, laser welded all-round blade guarantee outstanding cutting abilities. It's the perfect product for the intensive, professional use. No cooling brakes needed. Packing unit: 1 pc.

All kind of construction site materials, e.g. concrete, reinforced concrete, exposed aggregate concrete. Usable for hard stones, gneiss, granite, clinker bricks, porphyry, bricks, ductile and cast pipes etc.



The new U7 speed sets standards and combines all the features a top all-round disc can offer:

- ▶ Extremely high cutting speed thanks to its innovative segment technology with geometrically arranged high-performance diamonds. Segments and bond have been optimized for an optimum cutting speed and universal use.
- ▶ Flat 15 mm segments with compact volume, a high diamond density and an optimized bond ensure an outstanding lifetime during the daily all-round use.
- ▶ Effortless cutting without physical exertion.

DIMENSION MM	DIMENSION INCH	SPEED R.P.M.	NUMBER OF SEGMENTS	HEIGHT OF SEGMENTS IN MM	SHAPE	ITEM CODE	BAR CODE 4081600
115 x 2,2 x 22,23	4,5 x 3/32 x 7/8	13280	9	12	C3	4117135100	040562
125 x 2,2 x 22,23	5 x 3/32 x 7/8	12200	9	12	C3	4127135100	040579
180 x 2,4 x 22,23	7 x 3/32 x 7/8	8600	12	12	C3	4187135100	040586
230 x 2,6 x 22,23	9 x 7/64 x 7/8	6600	16	15	C3	4237135100	040593
300 x 3,2 x 20	12 x 7/64 x 3/4	6400	21	15	C3	4307134100	040609
300 x 3,2 x 25,4	12 x 7/64 x 1	6400	21	15	C3	4307136100	040616
350 x 3,2 x 20	14 x 7/64 x 3/4	5500	25	15	C3	4357134100	040623
350 x 3,2 x 22,23	14 x 7/64 x 7/8	5500	25	15	C3	4357135100	040630
350 x 3,2 x 25,4	14 x 7/64 x 1	5500	25	15	C3	4357136100	040647



Stone plates | Roof tiles

S3 turbo **perfect** **Dry and wet cutting** ★★★★★



The price-worthy alternative. Sintered dry cutting blade designed to cut construction site materials. The continuous cutting rim produces a clean cut without any chipping.

Packing unit: 1 pc.

The cutting depth should not exceed 2 cm.

Concrete, concrete roofing tiles, fireproof stones, gneiss, granite, terrazzo, bricks.



DIMENSION MM	DIMENSION INCH	SPEED R.P.M.	NUMBER OF SEGMENTS	HEIGHT OF SEGMENTS IN MM	SHAPE	ITEM CODE	BAR CODE 4081600
115 x 2,1 x 22,23	4,5 x 5/64 x 7/8	13280	-	7	GR	4113460100	040791
125 x 2,1 x 22,23	5 x 5/64 x 7/8	12200	-	7	GR	4123460100	040807
180 x 2,6 x 22,23	7 x 7/64 x 7/8	8600	-	7	GR	4183460100	040814
230 x 2,8 x 22,23	9 x 7/64 x 7/8	6600	-	7	GR	4233460100	040821

S5 turbo protect **evolution** **Dry and wet cutting** ★★★★★





Very comfortable turbo diamond blade with sandwich steel core.

For cutting of natural and artificial stone plates.

Packing unit: 1 pc.

Professional turbo blade also suitable for thicker stone plates of concrete, natural stone, roof tiles and terrazzo.

- ▶ pleasant working due to low vibration and reduced noise
- ▶ excellent cutting speed
- ▶ outstanding lifetime
- ▶ laterally extended segments for faster material ejection
- ▶ waved steel blade for optimal cooling
- ▶ the perfect combination for satisfactory working comfort, with good cutting ability at an attractive price



DIMENSION MM	DIMENSION INCH	SPEED R.P.M.	NUMBER OF SEGMENTS	HEIGHT OF SEGMENTS IN MM	SHAPE	ITEM CODE	BAR CODE 4081600
115 x 2,2 x 22,23	4,5 x 3/32 x 7/8	13280	-	7	GR	4115466100	040838
125 x 2,2 x 22,23	5 x 3/32 x 7/8	12200	-	7	GR	4125466100	040845
230 x 2,8 x 22,23	9 x 7/64 x 7/8	6600	-	7	GR	4235466100	040852

*S5 turbo protect - 8 db (A), dimension 230 mm, in comparison to a U4 diamond blade

DIAMOND CUTTING DISCS



S5 turbo

evolution

Dry and wet cutting



The premium turbo blade from DRONCO. The new type of 9 mm castle segments and a smooth, perforated stainless steel core are the prime features of this product. With this turbo blade you don't have to worry about limitations to the cutting depth. Smooth running, excellent all-round qualities, outstanding lifetime and clean cutting edges make this product a real all-rounder on any construction site. Especially for roofers and garden and landscape construction.

Packing unit: 1 pc.

Professional turbo blade also suitable for thicker stone plates. Very good cutting results and lifetime in concrete, concrete roofing slabs, gneiss, granite, terrazzo, bricks, roofing tiles.



DIMENSION MM	DIMENSION INCH	SPEED R.P.M.	NUMBER OF SEGMENTS	HEIGHT OF SEGMENTS IN MM	SHAPE	ITEM CODE	BAR CODE 4081600
115 x 2,2 x 22,23	4,5 x 3/32 x 7/8	13280	-	9	GR	4115441100	040869
125 x 2,2 x 22,23	5 x 3/32 x 7/8	12200	-	9	GR	4125441100	040876
180 x 2,5 x 22,23	7 x 3/32 x 7/8	8600	-	9	GR	4185441100	040883
230 x 2,5 x 22,23	9 x 3/32 x 7/8	6600	-	9	GR	4235441100	040890

Tiles | Stoneware

F3

perfect

Dry and wet cutting



Well proven, sintered diamond cutting blade with continuous cutting rim for clean cutting edges.

Packing unit: 1 pc.

For cutting tiles, wall tiles, floor tiles, stove tiles.



DIMENSION MM	DIMENSION INCH	SPEED R.P.M.	NUMBER OF SEGMENTS	HEIGHT OF SEGMENTS IN MM	SHAPE	ITEM CODE	BAR CODE 4081600
100 x 1,8 x 16	4 x 5/64 x 5/8	15300	-	5	GR	4103500100	040906
110 x 1,9 x 22,23	4,5 x 5/64 x 7/8	13900	-	5	GR	4113509100	040913
115 x 1,9 x 22,23	4,5 x 5/64 x 7/8	13280	-	5	GR	4113510100	040920
125 x 1,9 x 22,23	5 x 5/64 x 7/8	12200	-	5	GR	4123510100	040937
150 x 2,1 x 22,23	6 x 5/64 x 7/8	10200	-	5	GR	4153510100	040944
150 x 2,1 x 25,4	6 x 5/64 x 1	10200	-	5	GR	4153515100	040951
180 x 2,3 x 22,23	7 x 3/32 x 7/8	8600	-	5	GR	4183510100	040968
180 x 2,3 x 25,4	7 x 3/32 x 1	8600	-	5	GR	4183515100	040975
200 x 2,4 x 22,23	8 x 3/32 x 7/8	7600	-	5	GR	4203510100	040982
200 x 2,5 x 25,4	8 x 3/32 x 1	7600	-	5	GR	4203515100	040999
230 x 2,4 x 22,23	9 x 3/32 x 7/8	6600	-	5	GR	4233510100	041002
250 x 2,4 x 25,4	10 x 3/32 x 1	6100	-	5	GR	4253515100	041019

F4 cera

superior

Dry and wet cutting

★★★★☆



Tiler's favourite. Thin diamond cutting blade with a continuous turbo rim for cutting of stone plates of granite or other hard stones, as well as stoneware and high fired tiles. Fast and effortless cutting.

Offers an excellent cutting performance and lifetime.
Clean cutting edges.
7.5 mm segment height.
Packing unit: 1 pc.

For cutting stoneware and high fired tiles. Ideal for natural stone plates of marble, granite or terrazzo as well.



- ▶ outstanding cutting speed
- ▶ very good lifetime
- ▶ continuous turbo rim for clean cutting edges
- ▶ smooth and easy to use

DIMENSION MM	DIMENSION INCH	SPEED R.P.M.	NUMBER OF SEGMENTS	HEIGHT OF SEGMENTS IN MM	SHAPE	ITEM CODE	BAR CODE 4081600
115 x 1,4 x 22,23	4,5 x 1/8 x 7/8	13280	-	7,5	GR	4114512100	041026
125 x 1,4 x 22,23	5 x 1/8 x 7/8	12200	-	7,5	GR	4124512100	041033
150 x 2 x 25,4	6 x 5/64 x 1	10200	-	7,5	GR	4154517100	041040
180 x 2 x 22,23	7 x 5/64 x 7/8	8600	-	7,5	GR	4184512100	041057
180 x 2 x 25,4	7 x 5/64 x 1	8600	-	7,5	GR	4184517100	041064
200 x 2 x 22,23	8 x 5/64 x 7/8	7600	-	7,5	GR	4204512100	041071
200 x 2 x 25,4	8 x 5/64 x 1	7600	-	7,5	GR	4204517100	041088
230 x 2 x 22,23	9 x 5/64 x 7/8	6600	-	7,5	GR	4234512100	041095
250 x 2 x 25,4	10 x 5/64 x 1	6100	-	7,5	GR	4254517100	041101
300 x 2 x 25,4	12 x 5/64 x 1	6400	-	7,5	GR	4304517100	041118
300 x 2 x 30	12 x 5/64 x 1 1/5	6400	-	7,5	GR	4304518100	041507
350 x 2 x 25,4	14 x 5/64 x 1	5500	-	7,5	GR	4354517100	041125
350 x 2 x 30	14 x 5/64 x 1 1/5	5500	-	7,5	GR	4354518100	041514

DIAMOND CUTTING DISCS



F5 cera speed

evolution

Dry and wet cutting

★★★★★



Thanks to its thickness of only 1.2 mm and the special geometry of the continuous rim, the F5 cera speed ensures both, an exceptional cutting speed and a comfortable and smooth operation. The 10 mm segments guarantee an optimum lifetime. The integrated flange around the bore makes sure that the blade can be used safely in every situation.

Packing unit: 1 pc.

- ▶ 1.2 mm thin cutting rim with special geometry
- ▶ clean cutting edges
- ▶ minimal material loss
- ▶ exceptionally fast cutting
- ▶ easy to use
- ▶ 10 mm segment height

For cutting quarry tiles, stoneware and granite slabs.

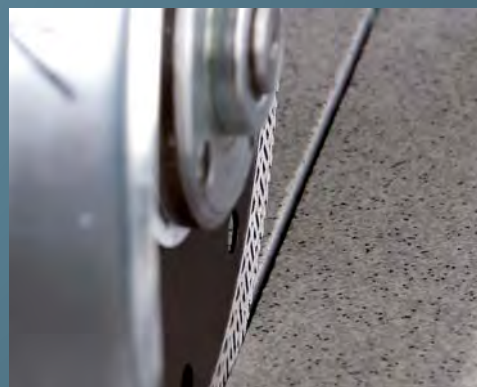

DIMENSION MM	DIMENSION INCH	SPEED R.P.M.	NUMBER OF SEGMENTS	HEIGHT OF SEGMENTS IN MM	SHAPE	ITEM CODE	BAR CODE 4081600
115 x 1,2 x 22,23	4,5 x 3/64 x 7/8	13280	-	10	GR	4115514100	041132
125 x 1,2 x 22,23	5 x 3/64 x 7/8	12200	-	10	GR	4125514100	041149

PLEASE NOTE

This product is also suitable for battery-powered angle grinders in diameters 115 and 125 mm.



Concrete

B4

superior

Dry and wet cutting

★★★★☆



Aggressive, laser welded diamond cutting blade for professional use in concrete and composite concrete paving. Particularly well-balanced segment bonding guarantees cutting without problems of all types of concrete, even with reinforcement.

Packing unit: 1 pc.

Concrete, cotto plates, exposed aggregate concrete, composite concrete paving, concrete roofing tiles, terrazzo.



DIMENSION MM	DIMENSION INCH	SPEED R.P.M.	NUMBER OF SEGMENTS	HEIGHT OF SEGMENTS IN MM	SHAPE	ITEM CODE	BAR CODE 4081600
115 x 2 x 22,23	4,5 x 5/64 x 7/8	13280	9	10	C3	4114110100	041156
125 x 2 x 22,23	5 x 5/64 x 7/8	12200	10	10	C3	4124110100	041163
150 x 2,2 x 22,23	6 x 3/32 x 7/8	10200	12	10	C3	4154110100	041170
180 x 2,2 x 22,23	7 x 3/32 x 7/8	8600	14	10	C3	4184110100	041187
230 x 2,4 x 22,23	9 x 3/32 x 7/8	6600	16	10	C3	4234110100	041194
300 x 2,8 x 20	12 x 7/64 x 3/4	6400	16	10	C3	4304105100	041200
300 x 2,8 x 22,23	12 x 7/64 x 7/8	6400	16	10	C3	4304110100	041217
300 x 2,8 x 25,4	12 x 7/64 x 1	6400	16	10	C3	4304115100	041224
350 x 2,8 x 20	14 x 7/64 x 3/4	5500	19	10	C3	4354105100	041231
350 x 2,8 x 22,23	14 x 7/64 x 7/8	5500	19	10	C3	4354110100	041248
350 x 2,8 x 25,4	14 x 7/64 x 1	5500	19	10	C3	4354115100	041255
400 x 3,2 x 25,4	16 x 7/64 x 1	4780	28	10	C3	4404116100	041262

DIAMOND CUTTING DISCS



B5

evolution

Dry and wet cutting

★★★★★



Laser welded top-class product with aggressive high-performance diamonds. Extremely fast, effortless cutting. For professional use in all sorts of concrete, even with reinforcement. No cooling brakes needed.

Packing unit: 1 pc.

Concrete, cotto plates, exposed aggregate concrete, composite concrete paving, concrete roofing tiles, terrazzo.



- ▶ best cutting abilities for a fast work progress
- ▶ excellent lifetime
- ▶ no cooling brakes

DIMENSION MM	DIMENSION INCH	SPEED R.P.M.	NUMBER OF SEGMENTS	HEIGHT OF SEGMENTS IN MM	SHAPE	ITEM CODE	BAR CODE 4081600
115 x 2 x 22,23	4,5 x 5/64 x 7/8	13280	8	10	C3	4115611100	040425
125 x 2 x 22,23	5 x 5/64 x 7/8	12200	9	10	C3	4125611100	040432
150 x 2,2 x 22,23	6 x 3/32 x 7/8	10200	10	10	C3	4155611100	040449
180 x 2,2 x 22,23	7 x 3/32 x 7/8	8600	12	10	C3	4185611100	040456
230 x 2,4 x 22,23	9 x 3/32 x 7/8	6600	15	12	C3	4235611100	040463
250 x 2,6 x 25,4	10 x 7/64 x 1	6100	18	12	C3	4255616100	040470
300 x 2,8 x 20	12 x 7/64 x 3/4	6400	18	12	C3	4305606100	040487
300 x 2,8 x 25,4	12 x 7/64 x 1	6400	18	12	C3	4305616100	040494
350 x 2,8 x 20	14 x 7/64 x 3/4	5500	21	12	C3	4355606100	040500
350 x 2,8 x 25,4	14 x 7/64 x 1	5500	21	12	C3	4355616100	040517
400 x 3,5 x 25,4	16 x 1/8 x 1	4780	28	12	C3	4405616100	040524
450 x 3,5 x 25,4	18 x 1/8 x 1	4250	32	12	C3	4455616100	040531
500 x 4 x 25,4	20 x 5/32 x 1	3800	36	12	C3	4505616100	040548
600 x 4 x 25,4	24 x 5/32 x 1	3170	42	12	C3	4605616100	040555

DIAMOND CUTTING DISCS

Granite | Hard Stones

G4 superior Dry and wet cutting ★★★★★



High-performance, laser welded diamond cutting blade for the effortless cutting of natural stones. The very soft bond was designed for applications where extremely shock-resistant diamonds are required.

Packing unit: 1 pc.

Special blade for hard natural stones such as granite, basalt, slate, terrazzo, clinker, gneiss and porphyry.



DIMENSION MM	DIMENSION INCH	SPEED R.P.M.	NUMBER OF SEGMENTS	HEIGHT OF SEGMENTS IN MM	SHAPE	ITEM CODE	BAR CODE 4081600
115 x 2 x 22,23	4,5 x 5/64 x 7/8	13280	8	10	C3	4114010100	041408
125 x 2 x 22,23	5 x 5/64 x 7/8	12200	9	10	C3	4124010100	041415
150 x 2,2 x 22,23	6 x 3/32 x 7/8	10200	12	10	C3	4154010100	041422
180 x 2,2 x 22,23	7 x 3/32 x 7/8	8600	14	10	C3	4184010100	041439
230 x 2,4 x 22,23	9 x 3/32 x 7/8	6600	15	12	C3	4234010100	041446
300 x 2,8 x 25,4	12 x 7/64 x 1	6400	21	12	C3	4304015100	041453
350 x 2,8 x 20	14 x 7/64 x 3/4	5500	25	12	C3	4354005100	041460
350 x 2,8 x 25,4	14 x 7/64 x 1	5500	25	12	C3	4354015100	041477
400 x 3,2 x 25,4	16 x 7/64 x 1	4780	28	12	C3	4404015100	041484

Abrasive Stones | Asphalt

A4 superior Dry and wet cutting ★★★★★



Powerful, laser welded diamond cutting blade for the professional use in abrasive stones. The wear-resistant bond of the product ensures its outstanding suitability for abrasive materials.

Packing unit: 1 pc.

Specially designed diamond blade for abrasive materials such as sand-lime stone, screed, plaster, sandstone, aerated concrete, bricks or pantiles.



DIMENSION MM	DIMENSION INCH	SPEED R.P.M.	NUMBER OF SEGMENTS	HEIGHT OF SEGMENTS IN MM	SHAPE	ITEM CODE	BAR CODE 4081600
115 x 2,2 x 22,23	4,5 x 3/32 x 7/8	13280	9	7	C3	4114215100	041279
125 x 2,2 x 22,23	5 x 3/32 x 7/8	12200	10	7	C3	4124215100	041286
230 x 2,4 x 22,23	9 x 3/32 x 7/8	6600	16	7	C3	4234215100	041293
300 x 2,8 x 20	12 x 7/64 x 3/4	6400	16	7	C3	4304225100	462159
350 x 2,8 x 25,4	14 x 7/64 x 1	5500	19	7	C3	4354227100	472158

DIAMOND CUTTING DISCS



A4 Asphalt

superior

Dry and wet cutting

★★★★☆



Powerful, laser welded diamond cutting disc for the professional use in asphalt. Also suitable for green concrete (up to 24 hours), screed and abrasive, soft materials.

Packing unit: 1 pc.

Special disc for asphalt, green concrete (up to 24 hours), screed and abrasive, soft materials.



DIMENSION MM	DIMENSION INCH	SPEED R.P.M.	NUMBER OF SEGMENTS	HEIGHT OF SEGMENTS IN MM	SHAPE	ITEM CODE	BAR CODE 4081600
300 x 2,8 x 20	12 x 7/64 x 3/4	6400	18	10	C1S	4304920100	041309
300 x 2,8 x 25,4	12 x 7/64 x 1	6400	18	10	C1S	4304930100	041316
350 x 2,8 x 20	14 x 7/64 x 3/4	5500	21	10	C1S	4354920100	041323
350 x 2,8 x 25,4	14 x 7/64 x 1	5500	21	10	C1S	4354930100	041330
400 x 3,2 x 25,4	16 x 7/64 x 1	4780	24	10	C1S	4404930100	041347
450 x 3,8 x 25,4	18 x 9/64 x 1	4250	27	10	C1S	4454930100	041354
500 x 3,8 x 25,4	20 x 9/64 x 1	3800	30	10	C1S	4504930100	041361
600 x 3,8 x 25,4	24 x 9/64 x 1	3170	36	12	C1S	4604930100	041378

A4 M

superior

Dry cutting / Wall slot cutter

★★★★☆



A powerful, laser welded, specially designed mortar raker disc for the easy removal of mortar residues from wall or screed joints.

Packing unit: 1 pc.

Special diamond blade for screed or plaster, aerated concrete, sandlime stone and bricks.



DIMENSION MM	DIMENSION INCH	SPEED R.P.M.	NUMBER OF SEGMENTS	HEIGHT OF SEGMENTS IN MM	SHAPE	ITEM CODE	BAR CODE 4081600
115 x 6,4 x 22,23	4,5 x 1/4 x 7/8	13280	9	7	C3	4114464100	041385
125 x 6,4 x 22,23	5 x 1/4 x 7/8	12200	10	7	C3	4124464100	041392

Diamond tile drill CeraDrill



The new Dronco CeraDrill drill-bits with vacuum-brazed diamond coating for maximum drilling performance.

They are used where conventional carbide or diamond drills reach their limits. The CeraDrill drill bit has an integrated cooling liquid that is released during the drilling operation.

Water cooling with its inconveniences is no longer necessary. Work efficiently and cleanly with CeraDrill.



With vacuum-brazed diamond coating

- ▶ Integrated cooling liquid
- ▶ Simple and efficient working
- ▶ No water cooling required
- ▶ For tiles, stoneware, quarry tiles

CERADRILL DIAMOND TILE DRILL



The drills are supplied with a protective cap. The cap has to be removed before the first use. After completion the cap must be refitted.

| For tiles, stoneware and quarry tiles.

DIMENSION DIAMETER X SHANK DIAMETER X LENGTH [MM]	ITEM CODE	BAR CODE 4081600
5 x 12 x 35	4000601100	400809
6 x 12 x 35	4000602100	400816
8 x 12 x 35	4000604100	400830
10 x 12 x 35	4000605100	400847
12 x 12 x 35	4000606100	400854
14 x 12 x 35	4000607100	400861
Drilling aid	4001100100	400939



Only for drilling without hammer! Optimal speed = 1500 rpm.



Operating instructions:

- ▶ Remove the protection cap.
- ▶ Start the drilling at an incline, then move to horizontal.
- ▶ Use the drilling aid for vertical drilling.
- ▶ Remove dust.
- ▶ Work with rotatory moves.
- ▶ A cooling break of 2 minutes is required after every hole.
- ▶ Clean the head after every hole with the cleaning stick provided (push dirt and dust inside the drill).
- ▶ When you have finished the application, refit the protective cap onto the drill.



Advice:

We recommend a trial drilling in a tile before you make a drilling operation in an already tiled bathroom!

CERADRILL-SET | ALUMINIUM CASE WITH 5 CERADRILL DRILL BITS, DRILLING AID AND CLEANING STICK



For tiles, stoneware and quarry tiles.

DIMENSION

Ø 5, 6, 8, 10, 12 mm

ITEM CODE

4000600100

BAR CODE

4081600

400496

Diamond dry drill for angle grinders CeraDrill DRY



Diamond dry drill CeraDrill DRY

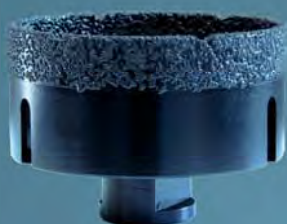

Product similar to photo

Vacuum-brazed, diamond coated special drill for dry drilling of fine stoneware, quarry tiles, ceramic and granite tiles.

fine stoneware, quarry tiles, ceramic and granite tiles.

The new CeraDrill DRY drills complete our CeraDrill range with diameters available from 20 mm up to 85 mm.

- ▶ for use on angle grinders with a M14 adaptor
- ▶ no cooling system necessary
- ▶ high drilling speed
- ▶ maximum lifetime

DIAMETER	LENGTH	DRILLING DEPTH	ADAPTOR	SPEED R.P.M.	ITEM CODE	BAR CODE 4081600
20mm	60mm	40mm	M 14	13280	4000610100	401004
27mm	60mm	40mm	M 14	13280	4000611100	401011
35mm	60mm	40mm	M 14	13280	4000612100	401028
40mm	60mm	40mm	M 14	13280	4000613100	401035
45mm	60mm	40mm	M 14	13280	4000614100	401042
50mm	60mm	40mm	M 14	13280	4000615100	401059
60mm	60mm	40mm	M 14	13280	4000616100	401066
65mm	60mm	40mm	M 14	13280	4000617100	401073
70mm	60mm	40mm	M 14	13280	4000618100	401080
75mm	60mm	40mm	M 14	13280	4000619100	401097
80mm	60mm	40mm	M 14	13280	4000620100	401103
85mm	60mm	40mm	M 14	13280	4000621100	401110

Packing: 1 pcs in plastic box, including cleaning stick



Diamond dry drill for angle grinders

available in twelve diameters from 20 up to 85 mm



The correct preparation and use:



max. r.p.m. 11.000

▶ We recommend the use on an angle grinder for 125 mm discs

Diamond core bits

for dry drilling of wall sockets and distribution boxes.

They provide the ideal means of cutting holes for wall sockets and light switches (68 mm) or distribution boxes (82 mm). (Other diameters available upon request)

BKT EVO Beton **Diamond core bit** ★★★★★



product similar to photo

Laser-welded core drill with outstanding service life and high efficiency. Suitable for all applications thanks to the innovative bonding of high-quality diamond segments.

Concrete (also lightly reinforced), clinker, brick.

DESCRIPTION	ITEM CODE	BAR CODE 4081600
Core bit Ø 68 mm	4000368100	400137
Core bit Ø 82 mm	4000382100	400236
Centre drill	4000478100	400304
6-point-connection	4000568100	400359
SDS-connection	4000668100	400403
Complete SDS-Set Ø 68 mm	4000268100	400120
Complete SDS-Set Ø 82 mm	4000282100	400229

BKT EVO Abrasiv **Diamond core bit** ★★★★★



product similar to photo

Very good service life, rapid drilling progress, laser-welded, very hard bonding.

Sand-lime brick, sandstone, grinding stone, masonry.

DESCRIPTION	ITEM CODE	BAR CODE 4081600
Core bit Ø 68 mm	4010010100	400519
Core bit Ø 82 mm	4010050100	400502
Centre drill	4000478100	400304
6-point-connection	4000568100	400359
SDS-connection	4000668100	400403
Complete SDS-Set Ø 68 mm	4000269100	400151
Complete SDS-Set Ø 82 mm	4000283100	400168



Diamond cup grinders

Diamond cup grinders designed for use in conjunction with grinding machines equipped with extraction systems and angle grinders. These discs provide the perfect abrasive solution for stone. The removal capacity and service life have proved themselves in millions of applications in practical use.

Application chart diamond cup grinders						
	DST	DST 56	DST 76	DST Turbo	DST Speed	DST BlueSpeed
●● very suitable						
● suitable						
○ limited suitable						
REMOVAL OF UNEVENNESS ON FLOOR PAVEMENT	●	●	●●	●	●	●
REMOVAL OF ROUGHNESSES ON STONE AND PLASTER FLOORING	●	●●	●	●●	●●	●●
REMOVAL OF CONCRETE RIDGES AFTER THE REMOVAL OF THE FORMWORK	●	●●	●	●●	●●	●●
REMOVAL OF DRIED PLASTER RESIDUES	●	●	●●	●	●	●
BEVELING OF CONCRETE- AND PAVING STONE	●	●	●	●●	●	●
BEVELING OF GAS-AREATED CONCRETE	●	●	●●	●●	●	●
REMOVAL OF THERMOPLASTIC PROTECTIVE COATINGS	●	●	●	●●	●●	●●
REMOVAL OF ADHESIVE REMAINDERS ON CONCRETE SURFACES	●	●	●	●●	●●	●●

PLEASE NOTE

Speed R.P.M. - 80 m/s:

115 mm	13280
125 mm	12200
180 mm	8600

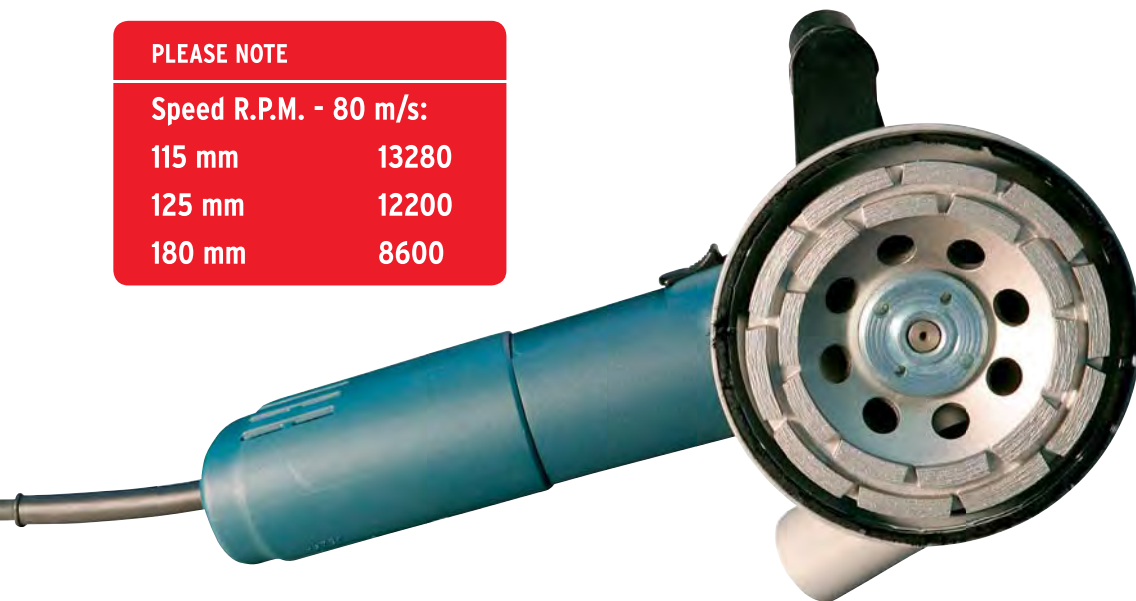

DIAMOND TOOLS

SECURITY ADVICE

When using diamond grinding discs, always make sure that the disc does not protrude from the protection of the machine => risk of injury

PLEASE NOTE

For concrete grinders, our diamond grinding discs DST 56 and DST 76 are also available in 22 mm height on request.

DST **perfect** ★★☆☆

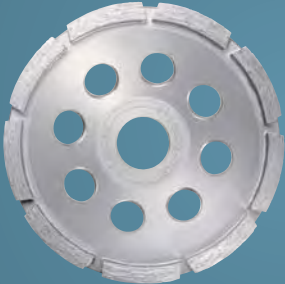

Designed to work on stone and plaster flooring, but also suitable for removing concrete ridges and for stone-masonry.
Packing unit: 1 pc.

Ideal for all applications on concrete, natural stone, floor pavement, construction-site materials.





DIMENSION MM	NUMBER OF SEGMENTS	SPEED R.P.M.	ITEM CODE SINGLE ROWED	BAR CODE 4081600
115 x 18 x 22,23	8	13280	4116033100	411027
125 x 18 x 22,23	7	12200	4126033100	421026
180 x 18 x 22,23	14	8600	4186033100	441024

DST 56 **special** ★★☆☆



Especially suited for grinding on concrete and natural stone. The optional single- or double-row arrangement of segments makes this DRONCO grinding disc ideal for all applications.
Packing unit: 1 pc.

For grinding on concrete and natural stone.

Single rowed



Double rowed

DIMENSION MM	NUMBER OF SEGMENTS	ITEM CODE SINGLE ROWED	BAR CODE 4081600	NUMBER OF SEGMENTS	ITEM CODE DUOBLE ROWED	BAR CODE 4081600
115 x 18 x 22,23	8	4116032100	411010	16	4116037100	411041
125 x 18 x 22,23	7	4126032100	421019	14	4126037100	421040
180 x 18 x 22,23	14			28	4186037100	441048



For concrete grinders, DST 56 is also available in 22 mm height on request.

DST 76 **special** ★★☆☆



Especially suitable for abrasive materials such as floor pavement, sand-lime stone, plaster, gas concrete, and green concrete. Ideal for all applications due to the optional single- or double-row arrangement of segments.
Packing unit: 1 pc.

For grinding on floor pavement, sand-lime stone, plaster, gas concrete, green concrete.

Single rowed



Double rowed

DIMENSION MM	NUMBER OF SEGMENTS	ITEM CODE SINGLE ROWED	BAR CODE 4081600	NUMBER OF SEGMENTS	ITEM CODE DUOBLE ROWED	BAR CODE 4081600
115 x 18 x 22,23	8			16	4116036100	411034
125 x 18 x 22,23	7	4126031100	421002	14	4126036100	421033
180 x 18 x 22,23	14			28	4186036100	441031

For concrete grinders, DST 76 is also available in 22 mm height on request.



DST TURBO

special

★★★★☆



Diamond cup grinder with turbo grinding rim, suited for grinding on concrete and natural stone. High stock removal with low power consumption. Outstanding lifetime, smoother grinding surface. Packing unit: 1pc.

For smoother grinding on concrete and natural stone.



DIMENSION MM	NUMBER OF SEGMENTS	SPEED R.P.M.	ITEM CODE SINGLE ROWED	BAR CODE 4081600
115 x 22,23	-	13280	4116041100	411065
125 x 22,23	-	12200	4126041100	420593

DST SPEED

special

★★★★☆



It's all in the mix: Welded segments with optimal geometry that contain special diamonds in an aggressive bonding. For all applications where fast and extensive stock removal is required. Packing unit: 1pc.

For concrete, floor pavement and natural stone.

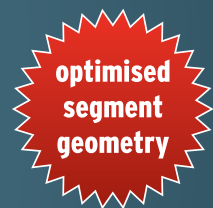

- ▶ 2.5 times higher stock removal*
- ▶ segments with special diamonds with aggressive bonding
- ▶ removal of thermoplastic protective coatings and adhesive remainders

* The result: The stock removal in grams per minute will increase by a factor of 2.5 (compared to Dronco DST 56 double row, on concrete C 25).

DIMENSION MM	NUMBER OF SEGMENTS	SPEED R.P.M.	ITEM CODE	BAR CODE 4081600
115 x 18 x 22,23	9	13280	4116042100	410488
125 x 18 x 22,23	9	12200	4126042100	420463

DST BLUE SPEED

special

★★★★☆



The DST Blue Speed offers the highest removal rate within the range of DRONCO cup grinders. The low weight in combination with the specially designed segments provides a comfortable, user-friendly and effective work.

For highest removal rate and a maximum comfortable grinding of concrete and natural stone, removing glue without glogging.



- ▶ outstanding removal rate
- ▶ high working comfort

DIMENSION MM	NUMBER OF SEGMENTS	SPEED R.P.M.	ITEM CODE	BAR CODE 4081600
115 x 22,23	8	13280	4116064100	412376
125 x 22,23	8	12200	4126064100	422375

Abrasives from DRONCO offer best quality regarding

- ▶ **Grinding efficiency**
- ▶ **Grinding finish**
- ▶ **Lifetime**
- ▶ **Safety**
- ▶ **Economy**



120 1-2-3-System
for hand sanding



124 1-2-3-4-System
for car body working



126 Fibre discs
for use on angle grinders



128 Semi-flexible discs
for use on angle grinders

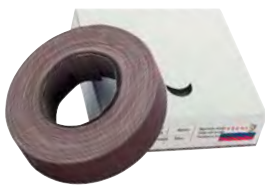

134 Economy rolls
for hand sanding



FLEXIBLE AND SEMI-FLEXIBLE ABRASIVES

DRONCO 1-2-3-System for manual sanding. Easy to handle and effective!

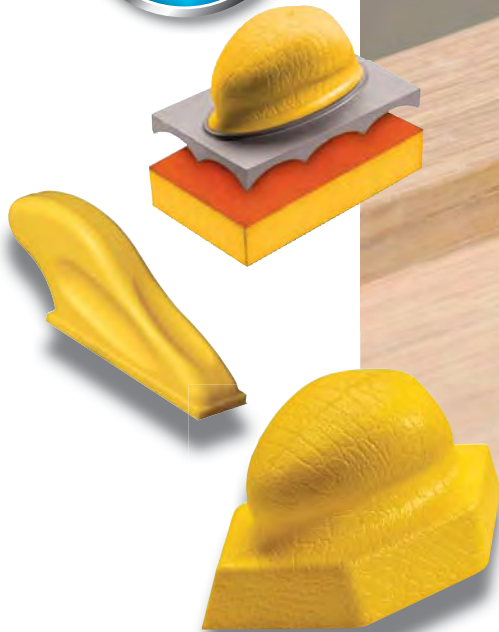

COLOUR CODED SHEETS FOR EASY RECOGNITION AS EXAMPLES BELOW:

1 st STEP: PRE-SANDING	2 nd STEP: SANDING	3 rd STEP: FINISHING
Pre-sanding with grit 80 for coarse grinding such as the removal of chipped paint and varnish as well as rounding of edges and burr removal.	Sanding with grit 120 for grinding works such as rust removal, effective paint removal and sanding of deep scratches and metal processing.	Finishing with grit 220. With this grit, you will obtain the optimum surface for subsequent glazing, painting or oiling of furniture.





DRONCO 1-2-3-System for manual sanding - easy to handle and effective! Ergonomic Mini-Sander

Mini Sander Set 91x27 mm

Dronco 1-2-3 System

Hand sanding



The Mini Sander is an easy-to-handle and effective grinding tool.

Pressure can be applied with the index finger which makes it possible to reach areas which are difficult to access. Very suitable for the restoration of furniture and for refurbishing windows, doors and window shutters.

The DRONCO 1-2-3 Mini Sander Set contains the ergonomic Sander plus 30 sanding sheets in three different grit. The abrasive paper can be used for both wood as well as metal.



10x
K80

10x
K120

10x
K220

Ergonomic Mini Sanding System for wood, metal, plastics, varnished surfaces and many more.



DESCRIPTION

CONTENT
PC.

ITEM
CODE

BAR CODE

Mini Sander Set 91 x 27 mm

Set with 30 sheets, assorted

6780200000

4081600
684001

Refill pack Mini Sander

Dronco 1-2-3 System

Hand sanding



10x
K80

10x
K120

10x
K220



DESCRIPTION

CONTENT
PC.

ITEM
CODE

BAR CODE

Refill pack Mini Sander 91 x 27 mm

30 sheets, assorted

6780210000

4081600
684018

DRONCO 1-2-3-System for manual sanding - easy to handle and effective! Ergonomic Hexagon Sander

Hexagon Sander Set 150 x 75 mm Dronco 1-2-3 System Hand sanding



With its ergonomic shape, the Hexagon Sander is the perfect tool for all sanding projects. It enables an especially easy-to-handle, smooth and effective sanding of larger surfaces that also reaches into corners, areas which are hard to access or on longer edges. The ideal tool for the restoration of furniture and for various sanding works for example on wood, fibreglass, plasterboard, metal or varnished surfaces.

The DRONCO 1-2-3 Hexagon Sander set contains six abrasive sheets in three different grits. The abrasive sheets can be used on both wood and on metal.



The DRONCO 1-2-3 Hexagon Sander set is also available with 50 abrasive sheets, assorted in three different grits (20 x K80, 20 x K120, 10 x K220)

Ergonomic manual sanding system for wood, metal, plastics, varnished surfaces and many more.



DESCRIPTION	CONTENT PC.	ITEM CODE	BAR CODE 4081600
Hexagon Sander Set 150 x 75 mm	Set with 6 sheets, assorted	6780220000	684032
Hexagon Sander Set 150 x 75 mm	Set with 50 sheets, assorted	6780221000	684070

Refill pack Hexagon Sander Dronco 1-2-3 System Hand sanding



DESCRIPTION	CONTENT PC.	ITEM CODE	BAR CODE 4081600
Refill pack Hexagon Sander 150 x 75 mm	6 sheets grit 80	6780230000	684049
Refill pack Hexagon Sander 150 x 75 mm	6 sheets grit 120	6780231000	684056
Refill pack Hexagon Sander 150 x 75 mm	6 sheets grit 220	6780232000	684063



DRONCO 1-2-3-System for manual sanding - easy to handle and effective! Sanding Sponge Set

Sanding Sponge Set with Handle

Dronco 1-2-3 System

Hand sanding



This handle allows the comfortable use of Sanding Sponges - without having to hold the sanding sponge in your hand.

The Sanding Sponges adjust to the processed surface very well and enable a smooth grinding.

- ▶ 1x Coarse Sponge grit 80, suitable for removing varnish and paint
- ▶ 2 x Medium Sponges grit 120, suitable for grinding of hard and soft wood, residue for plasterboard, fibreglass or metal surfaces
- ▶ 1x Fine Sponge grit 220 for the optimum grinding of surfaces before the application of a paint, glazing or varnish coating as well as before the oiling of furniture with teak oil or other liquid wood waxes.

Ergonomic manual sanding system for wood, metal, plastics, fibreglass, varnished surfaces, plasterboard and many more.



1x
K80

2x
K120

1x
K220

The DRONCO 1-2-3 Sanding Sponge set contains the ergonomic Handle plus four Sanding Sponges in three different grits (80, 120, 220). The Sanding Sponges can be used for multiple purposes.

DESCRIPTION	CONTENT PC.	ITEM CODE	BAR CODE
Sanding Sponge Set	Handle + 4 Sponges, grits assorted	6780290000	4081600 684100

DRONCO 1-2-3-4-System for car body works Mini Car Sander Set

Mini Car Sander Set

Dronco 1-2-3-4 System

Hand sanding



Designed for refinishing work on car bodies specifically smart repairs and awkward areas. DRONCO mini sanding set comes complete with three different grits of wet and dry paper.

- ▶ Step 3:
Grit 400 for primary flattening of repair area and first primer coats.
- ▶ Step 4:
Grits 1000 to 1500 for de-nibbing and removal of imperfections.
- ▶ The 1500 grit can be used for slight scratch removal.

Ergonomic mini sanding system with wet and dry abrasive paper for fine car body and refinishing work, smart repairs and repair in awkward areas.



10x
K400

10x
K1000

10x
K1500

The DRONCO Mini Car Sander Set contains the ergonomic sander plus 30 sanding sheets in three different grits (grit 400, grit 1000, grit 1500).

DESCRIPTION

CONTENT
PC.

ITEM
CODE

BAR CODE

Mini Car Sander Set 91 x 27 mm





Set with 30 sheets, assorted



6780201000

4081600
684025



DRONCO 1-2-3-4-System for car body works Oval Car Sander Set

Oval Car Sander Set	Dronco 1-2-3-4 System	Hand sanding	
  	<p>For sanding and refinishing works on larger surfaces and car bodies. DRONCO offers an oval freehand sander in a set with abrasive sheets in 4 grits :</p> <ul style="list-style-type: none"> ▶ Step 1: Grit 80 coarse: Removal of rust and damaged paintwork. Sanding of paint layers on wood, metal and plastics. ▶ Step 2: Grit 180 medium : Preparation of the repair area prior to body filler work or first primer coat and removal of imperfections. ▶ Step 3: Grits 80 and 180 for the dry finishing of body fillers. ▶ Step 4: Grits 320 and 400 for the final finish of repair area and for primary sanding. <p>The Oval car sander set contains the ergonomic sander plus 8 abrasive sheets in four different grits.</p>	<p>Sanding system for car body and refinishing works as well as the sanding of body fillers. Also suitable for use on wood, metal and plastics.</p>  <div style="display: flex; flex-direction: column; align-items: center;"> <div style="border: 1px solid black; border-radius: 50%; padding: 5px; margin: 5px;">2x K80</div> <div style="border: 1px solid black; border-radius: 50%; padding: 5px; margin: 5px;">2x K180</div> <div style="border: 1px solid black; border-radius: 50%; padding: 5px; margin: 5px;">2x K320</div> <div style="border: 1px solid black; border-radius: 50%; padding: 5px; margin: 5px;">2x K400</div> </div>	
DESCRIPTION	CONTENT PC.	ITEM CODE	BAR CODE
Oval Car Sander Set 152 x 77 mm	Set with 8 abrasive sheets, assorted	6780240000	4081600 684087

Refill pack Oval Car Sander	Dronco 1-2-3-4 System	Hand sanding	
		 	
DESCRIPTION	CONTENT PC.	ITEM CODE	BAR CODE
Refill pack Oval Car Sander 152 x 77 mm	8 abrasive sheets, assorted	6780250000	4081600 684094

FLEXIBLE AND SEMI-FLEXIBLE ABRASIVES

🔻 Fibre discs for use on angle grinders

Derusting, deburring, removal. DRONCO fibre discs are excellent for all abrasive works. They stand out for their high removal rate and long lifetime. Suitable backing pads round off the program.



Fibre discs	perfect A	Angle grinder				
		<p>Abrasive disc with normal corundum for machine sanding of metals. Backing pad necessary!</p>		<p> Metal, cast and wood.</p>		
DESCRIPTION	DIMENSION MM	DIMENSION INCH	CONTENT PIECES	ITEM CODE	BAR CODE 4081600	
A 16 Fibre	115 x 22	4 1/2 x 7/8	25	6011000000	601008	
A 16 Fibre	125 x 22	5 x 7/8	25	6012000000	602005	
A 16 Fibre	180 x 22	7 x 7/8	25	6018000000	604009	
A 24 Fibre	115 x 22	4 1/2 x 7/8	25	6011001000	601015	
A 24 Fibre	125 x 22	5 x 7/8	25	6012001000	602012	
A 24 Fibre	180 x 22	7 x 7/8	25	6018001000	604016	
A 36 Fibre	115 x 22	4 1/2 x 7/8	25	6011003000	601039	
A 36 Fibre	125 x 22	5 x 7/8	25	6012003000	602036	
A 36 Fibre	180 x 22	7 x 7/8	25	6018003000	604030	
A 40 Fibre	115 x 22	4 1/2 x 7/8	25	6011004000	601046	
A 40 Fibre	125 x 22	5 x 7/8	25	6012004000	602043	
A 40 Fibre	180 x 22	7 x 7/8	25	6018004000	604047	
A 50 Fibre	115 x 22	4 1/2 x 7/8	25	6011005000	601053	
A 50 Fibre	125 x 22	5 x 7/8	25	6012005000	602050	
A 60 Fibre	115 x 22	4 1/2 x 7/8	25	6011006000	601060	
A 60 Fibre	125 x 22	5 x 7/8	25	6012006000	602067	
A 60 Fibre	180 x 22	7 x 7/8	25	6018006000	604061	
A 80 Fibre	115 x 22	4 1/2 x 7/8	25	6011007000	601077	
A 80 Fibre	125 x 22	5 x 7/8	25	6012007000	602074	
A 80 Fibre	180 x 22	7 x 7/8	25	6018007000	604078	
A 100 Fibre	115 x 22	4 1/2 x 7/8	25	6011008000	601084	
A 100 Fibre	125 x 22	5 x 7/8	25	6012008000	602081	
A 100 Fibre	180 x 22	7 x 7/8	25	6018008000	604085	
A 120 Fibre	115 x 22	4 1/2 x 7/8	25	6011009000	601091	
A 120 Fibre	125 x 22	5 x 7/8	25	6012009000	602098	
A 120 Fibre	180 x 22	7 x 7/8	25	6018009000	604092	

Backing pads can be found on page 130



Fibre discs **special zirconium** **Angle grinder**



High performance fibre disc with zirconium corundum distinguishes through a very good lifetime and a high removal rate.

Backing pad necessary!

Stainless steel and mild steel

DESCRIPTION	DIMENSION MM	DIMENSION INCH	CONTENT PIECES	ITEM CODE	BAR CODE 4081600
AZ 36 Fiber	125 x 22	5 x 7/8	25	6722333000	674859
AZ 50 Fiber	125 x 22	5 x 7/8	25	6722335000	674866
AZ 60 Fiber	125 x 22	5 x 7/8	25	6722336000	674873
AZ 80 Fiber	125 x 22	5 x 7/8	25	6722337000	674880

Fibre disc AK **evolution ceramic** **Angle grinder**



Fibre disc with self-sharpening ceramic grain with special active components which endure aggressive stock removal with a high life time.

A backing pad must always be used in conjunction with this product.

- ▶ **aggressive stock removal**
- ▶ **high service life**
- ▶ **self-sharpening**

For surface grinding on chromium steel, chromium-nickel steel, high alloyed steel, titanium alloyed steel, brass and bronze.

DESCRIPTION	DIMENSION MM	DIMENSION INCH	CONTENT PIECES	ITEM CODE	BAR CODE 4081600
AK 36+ Fibre	115 x 22,23	4 1/2 x 7/8	25	6011814000	601718
AK 36+ Fibre	125 x 22,23	5 x 7 / 8	25	6012814000	602715
AK 60 Fibre	115 x 22,23	4 1/2 x 7/8	25	6011816000	601732
AK 60 Fibre	125 x 22,23	5 x 7 / 8	25	6012816000	602739
AK 80 Fibre	115 x 22,23	4 1/2 x 7/8	25	6011817000	601749
AK 80 Fibre	125 x 22,23	5 x 7 / 8	25	6012817000	602746

Backing pads can be found on page 130

🔻 Semi-flexible discs for use on angle grinders

Because of the special disc build-up of the Semi-flexible discs a higher grade of removal is reached than with fibre discs, however with a coarser finish. They are available with normal corundum and silicon carbide.

Attention: A backing pad is necessary.

Speciality: Description SC 24 is also used for care of hoofs.



Semi-flexible discs

perfect SIC

Angle grinder



Additive coated disc with silicon carbide.
Backing pad necessary!

Grinding of stone, mild steel and stainless steel, aluminium and plastic, care of hoofs (SC 24).

DESCRIPTION	DIMENSION MM	DIMENSION INCH	CONTENT PIECES	ITEM CODE	BAR CODE 4081600
SC 16	115 x 22	4 1/2 x 7/8	5	6121100000	615104
SC 16	125 x 22	5 x 7/8	5	6122100000	615302
SC 16	180 x 22	7 x 7/8	5	6123100000	615500
SC 24	115 x 22	4 1/2 x 7/8	5	6121101000	615111
SC 24	125 x 22	5 x 7/8	5	6122101000	615319
SC 24	180 x 22	7 x 7/8	5	6123101000	615517
SC 36	115 x 22	4 1/2 x 7/8	5	6121103000	615135
SC 36	125 x 22	5 x 7/8	5	6122103000	615333
SC 36	180 x 22	7 x 7/8	5	6123103000	615531
SC 40	115 x 22	4 1/2 x 7/8	5	6121104000	615142
SC 40	125 x 22	5 x 7/8	5	6122104000	615340
SC 40	180 x 22	7 x 7/8	5	6123104000	615548
SC 60	115 x 22	4 1/2 x 7/8	5	6121106000	615166
SC 60	125 x 22	5 x 7/8	5	6122106000	615364
SC 60	180 x 22	7 x 7/8	5	6123106000	615562
SC 80	115 x 22	4 1/2 x 7/8	5	6121107000	615173
SC 80	125 x 22	5 x 7/8	5	6122107000	615371
SC 80	180 x 22	7 x 7/8	5	6123107000	615579

Backing pads can be found on page 130



Backings pads for use on angle grinders

For fibre discs and semi-flexible discs. The backing pad by DRONCO takes care of the proper support on the machine. Best possible working conditions and efficient, fast working are thus guaranteed.



Backing pad

Angle grinder



Safety when using fibre and semi-flexible discs. Good scratch pattern due to damping and flexibility of the backing pad.

DESCRIPTION	DIMENSION MM	DIMENSION INCH	CONTENT PIECES	ITEM CODE	BAR CODE 4081600
M14 with velcro	115	4 1/2	1	6211205000	621020
M14 with velcro	125	5	1	6212205000	622027
M14 with velcro	180	7	1	6218205000	624021
M10 without velcro	115	4 1/2	1	6211100000	621013
M14 without velcro	115	4 1/2	1	6211105000	621006
M14 without velcro	125	5	1	6212105000	622003
M14 without velcro	180	7	1	6218105000	624007

Backing pad ribbed

Angle grinder



High performance backing pad with radial ribs. Medium hard rubber for an aggressive material removal.

DESCRIPTION	DIMENSION MM	DIMENSION INCH	CONTENT PIECES	ITEM CODE	BAR CODE 4081600
M14 ribbed	115	4 1/2	1	6211110000	621099
M14 ribbed	125	5	1	6212110000	622096
M14 ribbed	180	7	1	6218110000	624090

✔ Economy rolls for hand sanding

Economy rolls are the ideal professional tool for hand sanding. Applications range from working of wood to grinding of metal. The very flexible cotton cloth can quickly be torn off and is delivered in a practical dispenser. The product is user-friendly and available in different lengths, widths and grit sizes.

Perfect - brown

Economy rolls

Hand sanding



Very high quality resin bond universal abrasive belt for hand sanding, delivered in a practical dispenser, especially suited for metal and stainless steel. Flexible, lengths easy to tear off cotton cloth.

Can be delivered in two lengths: 25 m, 50 m

Backing material: J-cotton cloth, very flexible

Grit: normal corundum Coating: close Bond: resin bond

Metal, stainless steel

DIMENSION MM	GRIT SIZE	CONTENT PIECES	ITEM CODE	BAR CODE 4081600
50mm x 50m	60	1 roll	6790073000	679731
50mm x 50m	80	1 roll	6790074000	679748
50mm x 50m	120	1 roll	6790075000	679755
50mm x 50m	180	1 roll	6790076000	679762
50mm x 50m	240	1 roll	6790077000	679779



Grinding cups

The high removal rate of these conical abrasives makes them the ideal solution for coarse grinding work. The maximum operating speed should not exceed 45 m/s.

Examples of possible applications:

- ▶ **cleaning of shutter boards**
- ▶ **grinding away concrete ridges after the removal of the formwork**
- ▶ **coarse grinding work in the metal-working industry**

PLEASE NOTE

Max. R.P.M. 8500 - 50 m/s

Grinding cups metal



Suitable for all angle-grinders. Available in fine, medium, coarse.

Coarse grinding work on metal. The slight angle of the grinding cup also allows to work on welding seams.

DESCRIPTION	STRUCTURE	DIMENSION MM	CONTENT PIECES	ITEM CODE	BARCODE 4081600
AS 16 Q	Coarse	110/90 x 55 x 22,23	1	6311000000	631005
AS 24 Q	Medium	110/90 x 55 x 22,23	1	6311001000	631012
AS 36 Q	Fine	110/90 x 55 x 22,23	1	6311003000	631036

Grinding cups stone



Suitable for all angle-grinders. To grind the surfaces of natural and synthetic stones with a high removal rate. Available in very fine, fine, medium, coarse

Working on all types of stone

DESCRIPTION	STRUCTURE	DIMENSION MM	CONTENT PIECES	ITEM CODE	BARCODE 4081600
CS 16 N	Coarse	110/90 x 55 x 22,23	1	6311010000	631050
CS 24 N	Medium	110/90 x 55 x 22,23	1	6311011000	631029
CS 60 N	Fine	110/90 x 55 x 22,23	1	6311016000	631074
CS 120 N	Very Fine	110/90 x 55 x 22,23	1	6311019000	631081

Available also with M14.

🔻 Vitrified wheels

DRONCO have developed vitrified wheels for the use on bench grinders. They are supplied with a bore size of 32mm and an already inserted reducing bush from 32mm down to 20mm.

Vitrified wheels



Grinding wheels designed for specific purposes in various grit sizes.

Metal, stainless steel

DESCRIPTION	STRUCTURE	DIMENSION MM	CONTENT PIECES	ITEM CODE	BARCODE 4081600
NK 24	Coarse	150 x 20 x 32/20	1	6561500000	656039
NK 24	Coarse	175 x 20 x 32/20	1	6561700000	656060
NK 24	Coarse	200 x 20 x 32/20	1	6562000000	656091
NK 60	Medium	175 x 20 x 32/20	1	6561710000	656077
NK 60	Medium	200 x 20 x 32/20	1	6562010000	656114
SIC 80	Fine	150 x 20 x 32/20	1	6561520000	656053
SIC 80	Fine	175 x 20 x 32/20	1	6561720000	656084
SIC 80	Fine	200 x 20 x 32/20	1	6562020000	656107





▼ Promotion box technical brushes with fast moving items

► Promotion box for drilling machines



► Promotion box „Profi“ for angle grinders



PROMOTION BOX CONTAINING TECHNICAL BRUSHES

Technical brushes packed in attractive, self-explanatory promotion box. Available are boxes for the use on drilling machines or type "PROFI" for the use on angle grinders. Mixed contents description as below:

Pure sales success – for product shelves and sales counter, P.O.S.

Content promotion box for drilling machines, 54 pieces

12 x Lend brush PBW 6	Ø 25 x 6,0 x 0,30 mm
6 x Wheel brush RB 6	Ø 100 x 6,0 x 0,30 mm
20 x Wheel brush RB 6	Ø 75 x 6,0 x 0,30 mm
10 x Cup brush TB 6	Ø 50 x 6,0 x 0,30 mm
6 x Cup brush TB 6	Ø 75 x 6,0 x 0,30 mm

Content promotion box PROFI for angle grinders, 36 pieces

5 x Tapered brush KBZ	Ø 100 mm x M14 x 0,5 mm
5 x Tapered brush KBW	Ø 100 mm x M14 x 0,3 mm
7 x Wheel brush RBZ	Ø 115 x 22,23 mm x 0,5 mm
7 x Wheel brush RBZ	Ø 125 x 22,23 mm x 0,5 mm
6 x Cup brush TBZ	Ø 65 mm x M14 x 0,5 mm
6 x Cup brush TBW	Ø 60 mm x M14 x 0,3 mm

Z= twist-knotted wire
W= crimped wire

DESCRIPTION	ITEM CODE	BAR CODE 4081600
Brush promotion box for Drilling machines	6903017100	707182
Brush promotion box for angle grinders	6903018100	707199

Index

A		AS 46 T Mini cutting discs	41
A4	108	AS 46 V	28
A4 Asphalt	109	AS 60 T INOX 1 mm	23-24
A4 M	109	AS 60 V 1 mm	25
A 24 R	35	AS 60 W 0,8 mm	22
A 30 S	42	AS 60 W HT	26
A 30 T	56	AZ 30 S	58
A 46 R	26	AZ 30 T	58
A 60 R 1 mm	23	B	
ACS 46/60 T MULTI 1,2 mm	31	B4	106
AK 24 V CeraMaxx	59	B5	107
AK 36 T CeraMaxx	59	Backing pad	129
AK 46 V CeraMaxx	30	Backing pad ribbed	129
AK 60 V CeraMaxx	30	BKT EVO Abrasiv	114
Application chart diamond cup grinders	115	BKT EVO Beton	114
Application chart diamond discs	94-95	C	
Application chart flap discs	65	C 24 R	50
Application chart grinding discs metal	55	C 46 R	49
Application chart metal cutting discs	21	C 60 R	48
Application chart grinding discs stone	55	CERADRILL Diamond Tile Drill	110
Application chart stone cutting discs	47	CERADRILL DRY Diamond Dry Drill	112
AS 24 R BAHN	40	CERADRILL-SET	111
AS 24 S Cast/Iron	60	Coarse cleaning fleeces for straight and cylindrical grinders	83
AS 24/30 T	57	Coarse cleaning fleeces for the use on angle-grinders	82
AS 30 R	56	Coarse cleaning fleece set	82
AS 30 S HT	37	CS 24 R	51
AS 30 S INOX	34	CS 30 asphalt/ductile	51
AS 30 S INOX	57	CS 30 S	61
AS 30 S	36	CS 46 ALU	39
AS 30 S	42	CS 60 ALU	39
AS 30 T	34	D	
AS 30 T INOX	58	DB 4	98
AS 30 T	37	Dealer Information	12-17
AS 30 V	38	DRONCO GmbH	4-17
AS 36 S INOX	43	DST 56	116
AS 36 T	43	DST 76	116
AS 36 V	38	DST BLUE SPEED	117
AS 46 / AS 30 T INOX Cut+Grind	33	DST SPEED	117
AS 46 / AS 60 T INOX FreeCut	32	DST TURBO	117
AS 46 ALU	60	DST	116
AS 46 T INOX	27	E	
AS 46 T Mini grinding discs	61	Evolution ceramic, Fibre Disc AK	127

INDEX

F		S	
F3	103	S 3 turbo	102
F4 cera	104	S 5 turbo	103
F5 cera speed	105	S 5 turbo protect	102
G		Sanding Sponge Set with Handle	123
G-A	66	Special zirconium, Fibre Disc	127
G-AK	72	ST-7	96
G-AZ A	67	T	
G-AZ	70	Tensioning shaft	83
G-AZ Maxx	71	Tensioning shaft for mini cutting discs	41
G-C	74	U	
G4	108	U3	96
Gloss Polishing flap disc for angle-grinders	80	U4	97
Grinding cups metal	131	U4 protect	98
Grinding cups stone	131	U4 speed	97
H		U5 protect	100
Hexagon Sander Set	122	U5 speed	99
J		U7 speed	101
J-AK	73	V	
J-AZ A	69	Vitrified wheels	132
K			
K-AZ A	68		
M			
Mini Car Sander Set	124		
Mini Sander Set	121		
O			
Oval Car Sander Set	125		
P			
perfect A Fibre Disc	126		
Perfect SIC semi-flexible disc	128		
Polishing compound	80		
Polishing flap disc for angle-grinders	77		
Polishing flap disc set	77		
Polishing System, 10 pcs.	81		
Polishing wheel	79		
Promotion Box containing technical brushes	133		
R			
Refill pack Hexagon Sander	122		
Refill pack Mini Sander	121		
Refill pack Oval Car Sander	125		



OSBORN PREMIUM PROGRAMME

2017



FINISH WITH OSBORN.

OSBORN WORLDWIDE



SALES OFFICES IN

23
COUNTRIES

CONVINCING
FIGURES

SERVICE IN

120
COUNTRIES

KNOW-HOW FOR
MORE THAN

125
YEARS

MORE THAN

2.000
EMPLOYEES
WORLDWIDE

SUBSIDIARIES IN

13
COUNTRIES

YOUR FIRST CHOICE FOR ALL SURFACES

Dear customers,

you can look at it whatever way you want ...

On approximately 300 pages our new catalogue presents the range of products for mechanical surface treatment from Osborn and Dronco. No matter if you are looking to cut, grind, sand, clean, brush or polish – we are at your service.



We are Osborn and Dronco. With a combined experience of more than 180 years in surface treatment we do have a solution for nearly everything. And in case we don't have it yet, we develop it together with you. This is our strength: We already have 10,000 solutions for standard applications on stock. In addition we have developed more than 100,000 tailored solutions for our customers. And we also gladly assist you in finding the right product.

If today you are only an Osborn customer, we invite you to getting to know the other part of us. Just turn the catalogue around and see what Dronco has to offer. And the great thing is: You don't need another customer idet number or an additional contact person. Just speak to your already known contact and order products on you already existing customer account. Give it a try.

We are looking forward to our further cooperation!

**Your experts in surface treatment,
Osborn International GmbH**



➔ Find the Dronco products starting at PDF-page 3.

BRUSHES 14



HAND BRUSHES 73

POLISHING / SATINISING 87

BRUSHTECHNOLOGY INDUSTRIAL 107

HEAVY-DUTY IDLER-ROLLERS 139

SPECIALS 141

INDEX 149

BEST SERVICE AT ALL LEVELS



Service means just that - serving.

It's not just a matter of dependable ordering, attractive conditions and fast delivery. We have that already, of course. **We offer our customers a 100% service.**

Therefore service at Osborn starts very early on.

Good service starts with a good product.

A good tool just feels right and fits 100% to the machine you are using. That's why we place great value on the ergonomics and handling of our products. Osborn tools are designed to suit all common machines and are also tested thoroughly on them.

Good service for us means developing products that make your work easier.

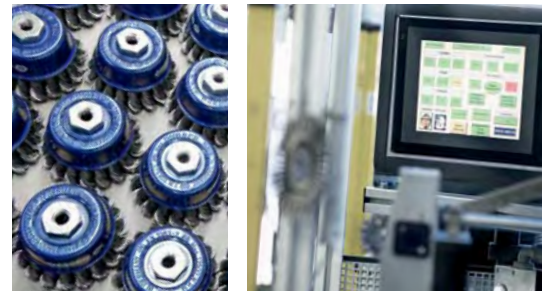

In our R&D lab, we use latest technology to achieve maximum ease of use and safety.

Tailored solutions for you.

We develop products that perfectly suit the needs and demands of our customers. It doesn't matter whether they're from our huge standard range or the result of a customer-specific solution developed jointly with you.

Our aim is to always make the user's work easier.

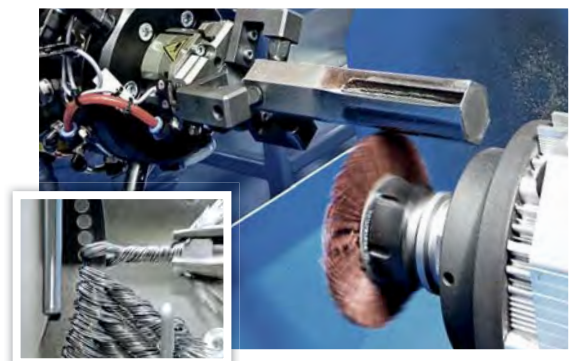

Our packaging as our best salesman.

A lot of information has to be taken in and considered at the self-service shelf and on the packaging. We favour clear messages, easily understood self-explanatory information. Well designed packages can help customers to find the right product and save consultation time on the dealer's part.





No matter when or where, you can place your order and we see to a timely delivery.

24/7 availability, worldwide.

Quick response and delivery times are a fundamental element of a modern service/customer relationship.

For you as a dealer, this is the basis for a good and profitable business partnership. In addition things must also be easy and reliable.

nexMart offers its dealers the convenience of an online order platform and is available in many European countries for some time now.

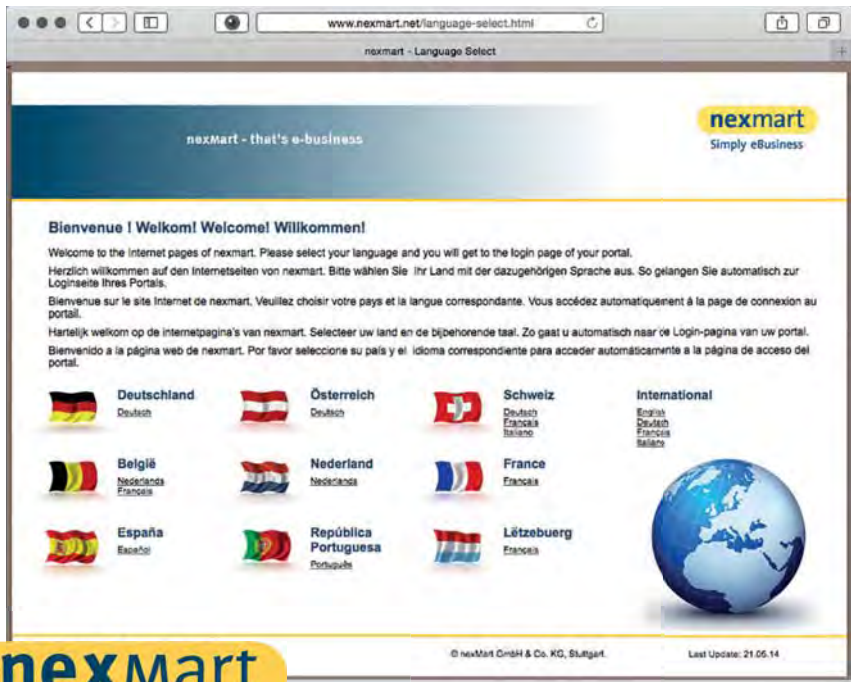

nexMart – easy ordering around the clock.

The nexMart Internet platform is the biggest information source in the industry and allows convenient, digital ordering with full order functionality – whenever and wherever you need it.

"OSBORNSOLUTIONS" @ YOUTUBE



Comprehensive product and application information, tips and suggested solutions for a professional surface treatment – available 24/7 on our YouTube channel.



The official Osborn YouTube channel.

Scan QR-Code or use the following link to get there:
youtube.com/osbornsolutions

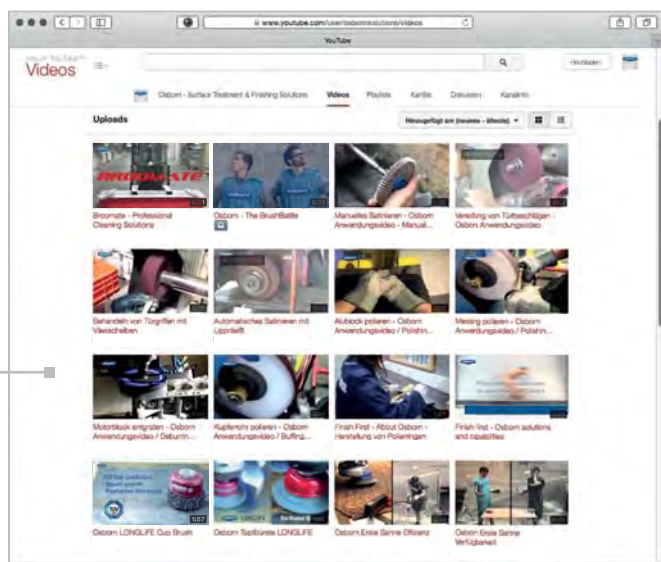

A QUESTION OF SAFETY



Work safety – a key issue for users and dealers.

That's why Osborn takes the subject very seriously.
Users and dealers are safe with us because many **Osborn tools are TÜV-certified.**
This means safety is not only perceivable but also measurable.

Safety with a seal. More than 700 Osborn products are TÜV-certified.

Osborn quality is not just a promise but is signed and sealed.
More than 700 of our products have been certified by TÜV-Süd. This makes Osborn products the only ones on the market to meet the highest standards of quality and safety.

Our quality standard: to always have the best tool for every job.

That is why we combine top-quality raw materials, years of experience, high-precision manufacturing methods so our customers can rely on Osborn.



One of more than 700 certified Osborn products.



Osborn: Officially good!

A TÜV-seal means „tested without compromise“ and indicates quality at the first glance.

Osborn is the only manufacturer in its sector to obtain this certification.





Visible quality.

The TÜV-seal on the packaging catches the eye immediately. Clearly visible on the shelf, the seal tells consumers immediately that Osborn quality has gained official confirmation.

The package shows that this article is TÜV-certified.

Unique tool. Repeated testing.

All products undergo a wide variety of tests for TÜV-Süd certification.

In addition to these checks, all our products are subjected to our own comprehensive tests in order to guarantee the Osborn quality standard.

Our customers benefit time and again from double quality testing which ensures consistently high standards in terms of materials, finish and safety.

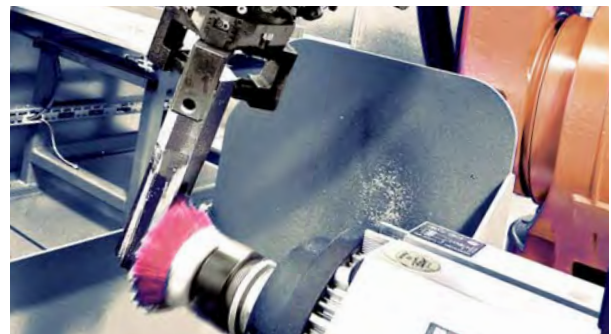

Certified quality - compliance with all standards.

In addition to meeting the demands for the TÜV-Süd certification, our products are also manufactured in accordance with EC standards EN 1083-1 and EN 1083-2. We also hold the DIN EN ISO 9001:2015 certification and have implemented into this an energymanagement system according to ISO 50001:2011.

You can find our certificates on our website at:
www.osborn.de/de-de/service/zertifikate.html



YOUR ADVANTAGE EXKLUSIVELY WITH OSBORN

With its TÜV certification, Osborn promises more than just a quality commitment. Osborn products have proven they perform as promised. Under all conditions.

This clearly makes Osborn the first choice when it comes to superbly manufactured tools of unbeatable quality.

MAXIMUM QUALITY



First class tools – better results and satisfied customers.

As longtime expert in mechanical surface treatment solutions we know, what makes a good tool: High performance, efficiency and safety. Osborn professional tools are the result of this pursuit. One example unifying all these factors is the Osborn LONGLIFE brush with its special filament.

Osborn Tools – First Choice in Quality.

Osborn LONGLIFE – Performance Champion.

- Min. 5-times less wire breakage and wear
- Material friendly and non-stock removing
- Available in Ø 60, 75, 80, 100 mm

Best of both worlds.

Extremely long lasting cup brush with LONGLIFE-filaments for a fine, satinised surface finish. Ideal for descaling and cleaning of larger surfaces.

High performance of a knotted brush yet as material friendly as a crimped wire brush.

LONGLIFE in detail:

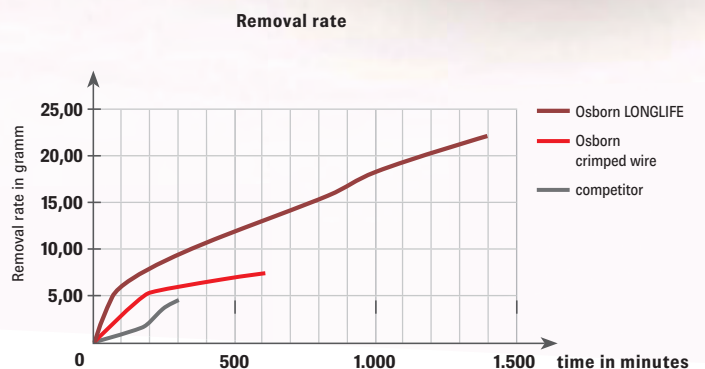

Testresult Osborn LONGLIFE

QUALITY & PERFORMANCE TESTS: TEST-ROBOT

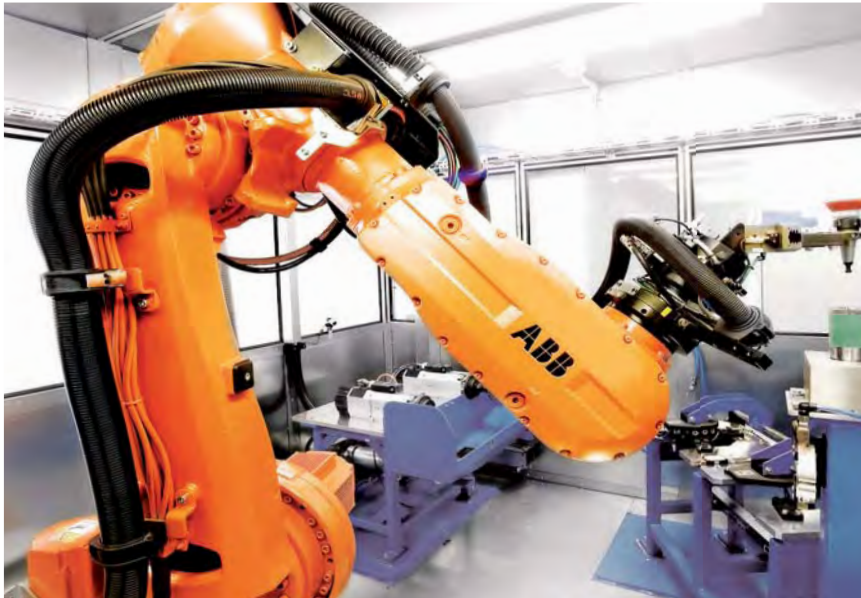

Test robot in our R&D lab in Burgwald

YouTube



The test robot at work.

The QR code will take you directly to the film clip or use the address below to visit our YouTube channel.

Watch the video on YouTube:

[YouTube.com/osbornsolutions](https://www.youtube.com/osbornsolutions)

Accurate testing without compromise.

At Osborn, we use a state-of-the-art industrial robot to determine the performance of our products. The robot delivers accurate results and makes it possible to carry out a wide range of quality assurance checks, all under the same conditions.

As well as providing pure performance data, the robot helps us through continuous monitoring to guarantee a consistent quality standard. Complex processes are easily replicated using realistic simulations to optimise the tool.

Our Qualitylines

All our products are manufactured with greatest care in order to meet your demands and requirements in the best way.

For your orientation, we have especially categorized the machinebrushes for angle grinder, power drill and high-speed as well as the handbrushes into three productlines: From solid DIY-quality to high-end products for demanding industrial applications. Just look out for the productline being mentioned directly next to the product image.

- PERFECT** Products in solid DIY-quality.
- SPECIAL** High-performance products in industrial quality. Nearly the whole range is TÜV-Süd certified.
- EVOLUTION** High-end products with highest quality materials for demanding industrial applications and long service-life.



Info on qualityline directly with the product image

Pos
Solutions for specialized trade

FASTER TO THE RIGHT PRODUCT

The best advice. On the packaging.

Osborn packaging makes it easy to find the right product.

In just **four quick steps** you can find the perfect tool from our wide range of brushes and other products. Clearly displayed on our POS materials are the four, self-explanatory steps you need to obtain expert advice.

2. Quick info on trim materials:

Here, colours and text provide users with key information on the trim material. The colours also appear in the catalogue to help with material selection.







1. Easy selection:

Icons on the packaging tell you which machine to be used. Angle grinders, power drills, or high-speed drill – this question is quickly answered.



3. Detailed info on the product:

The details about the product provide information on wire, bore/thread, rounds per minute, etc.

Bestell-Nr. Item No. Ref. Bestel-nr.	 (D) Draht ø (mm) (E) Wire (F) Fil (G) Draad	 (B) Bohrung (E) Arbor hole (F) Alésage (G) Asgat-dia.	 (G) Gewinde (E) Thread (F) Filetage (G) Schroefdraad	 max R.P.M. max min ⁻¹ max tr/mm max R.P.M.
0002 608153	0,50	-	M14	8500

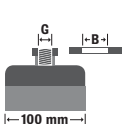



4. TÜV-Safety

TÜV-Süd seal on the package means: This article is certified.



SCAN INFORM DECIDE

Inform online – decide at the shelf.

Osborn links the shelf to the Internet. Customers have the option of loading additional details and product information directly onto their Smartphone, using the QR codes on our packaging. It is so easy to clear up questions about our products right there at the shelf.

The QR codes are located on our individual packaging, on loose products in boxes and on the display card.



Code on the packaging and the web at the POS.



1. QR-Code on shaft-tags.



2. QR-Code on packaging.



3. QR-Code on display cards.



YOUR OSBORN- ADVANTAGE

Efficient advice

The QR-code can be a great source of advice as it allows the salesperson to access videos, pictures and information on the selected product quickly at the POS.

Pos Solutions for specialized trade

INTELLIGENTLY PACKAGED & PRESENTED

Osborn products come in different kinds of packaging, with each version explaining and promoting the product to the full.

1. Box / individual packaging



2. Display card

Users can immediately see which machine is to be used with the brush.



3. Shaft-tag in assortment box

Shaft-tags provide basic information like EAN code. The header board of the box can be used front and backside (for wood or metal brushes). The box can be used length or crossways.



4. Flexibility

Presenting the products professionally: With the help of our packaging, you can compile your individual sales walls.

Contact us for more details.

(Pictures show a sample configuration)

Product overview

Find your tool quickly



BRUSHES 14

Osborn brushes – first class tools for every application

Brushes for angle grinders
Cleaning, non-stock removing and efficient



Brushes for power drills
For power drills of all makes



Brushes for high-speed drills
Ideal tools for high-speed machines



Finishing Drums for Satisers
Drums for the perfect surface pattern



HAND BRUSHES 73

Osborn hand brushes, brooms and paint brushes – ideal for all manual jobs

Basic deburring, cleaning, descaling and paint stripping



POLISHING /
SATINISING 87

Osborn surface technology – for the perfect finish

Your wide rang of polishing tools



BRUSHTECHNOLOGY
INDUSTRIAL 107

Osborn Industrial – high performance for all industrial applications

Ideal solutions for your manufacturing process



HEAVY-DUTY
IDLER-ROLLERS 139

Osborn Load Runners – precise load control

Idler Rollers and rails for heavy duty applications



SPECIALS 141

Osborn Specials – versatile all-rounders

Strip brushes in many different configurations

INDEX 149

Brushes

Introduction & technical information

PRODUCT INTRODUCTION BRUSHES

Osborn brushes – first-class, brand-name tools for every application.

There are any number of tasks and applications for a brush. But it is not just the job that determines which brush to use. The tool used and the surface to be finished are equally important.

To ensure you always have the best brush in each case, you should entrust your surfaces to a brand-name brush. This is the only way to guarantee that everything from trim material to brush shape is correct.

Overview of the most common machine brushes:

Wheel brushes
Finishing of solid or hollow rods, profiles, welded seams, cut edges, gears, grooves, narrow areas.

Cup brushes
Efficient finishing of large areas, welding seams and metal plates.

End brushes
Accurate finishing of inaccessible places.

Bevel brushes
Ideal tool for finishing corners, edges or inaccessible places, as well as surface cleaning.

Flap wheel brushes
Can be used without problems in drills because of the light plastic body.

Hand brushes, brooms and bristles
For universal use.

Tube & internal brushes
Ideal for finishing drill holes, threads or cross holes (internal finishing chapter).

THE OSBORN- ADVANTAGE

Osborn has the right brush for every application.

As a professional partner to trade and industry, Osborn sells high-performance tools suitable for all applications throughout the world. You can rely on Osborn's many years of experience and skill.

Brushes

Introduction & technical information

Trim materials: the right material for every application

For our products, we only use trim materials that we have developed ourselves or which have been specifically selected. Constant laboratory tests ensure high material quality. Your Osborn tool is always perfectly suited to a certain type of brushing work. Our technical sales department will be pleased to advise you on the ideal trim material for your given application.

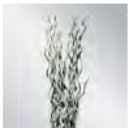

Steel wire, crimped

- Most common trim materials
- For flexible brushing tools
- Suitable for light surface treatment and deburring operations



Steel wire, cordwire (Longlife)

- Cordwire with high tensile strength
- Extremely long-lasting
- Combined advantages of crimped and knotted wire
- For light derusting operations

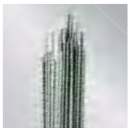

Steel wire, straight or knotted

- For extreme brushing requirements
- For brushing tools with less flexibility
- Ideal for cleaning weld seams and removing heavy deposits of scale or corrosion

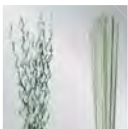

Osborn special steel wire, crimped or knotted

- Heavy duty steel wire with high tensile strength
- High elongation and long brush life
- For extreme brushing demands



Stainless steel wire, crimped, straight or knotted

- Most commonly used alloys: 1.4310 and 1.4401 (1.4571 available on request)
- For use where residue from normal steel wire would contaminate surfaces.



Brass wire

- Surface finishing on non-ferrous materials (copper and brass)



Brass-coated steel wire, mono wire

- Single wires
- High tensile strength
- For demanding brushing and deburring operations



Novoflex-B

- Abrasive spheres on a flexible structure
- Self-centring
- Creation of surfaces with a high contact ratio (plateau finish)



Brass-coated steel wire, cordwire

- Cordwire with high tensile strength
- For demanding brushing and deburring operations, as well as for structuring wood

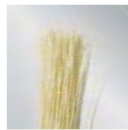

Tampico fibre

- Pure plant fibre
- For wet and dry cleaning operations
- Heat-resistant
- In combination with compound also suitable for polishing

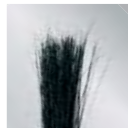

Horse hair

- Animal hair
- For light cleaning operations
- Suitable for sealing

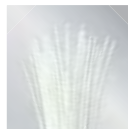

Synthetic filaments

- Highly flexible
- Resistant to weak acids and alkaline solutions
- Wear resistant



Abrasive filament, aluminium oxide

- Nylon filaments impregnated with abrasive grit
- Light deburring of steel and non-ferrous metals



Abrasive filament, silicon carbide

- Nylon filaments impregnated with silicon carbide
- Uniform performance as new abrasive particles come to the surface
- High elasticity with no danger of breakage
- Long brush life
- For deburring/descaling, roughening and grinding



Novofil

- High-performance, high-tech material
- Flat or round filaments
- Broad range of materials, different degrees of hardness
- For deburring and internal finishing



Please also note our different qualitylines for products.

You will find the definition in our chapter BRUSHES directly with the product image.

PERFECT Products in solid DIY-quality.

SPECIAL High-performance products in industrial quality. Nearly the whole range is TÜV-Süd certified.

EVOLUTION High-end products with highest quality materials for demanding industrial applications and long service-life.

Brush trim and material suitability

The trim material determines the suitability of the selected brush for the surface to be finished.

A quick overview of the suitability of your brush can be found in the trim and material charts in the info headings on the product pages.

TRIM AND MATERIAL

Simple equation: the right trim for the material being finished.

Product available with:

steel wire, crimped →

steel wire, stainless →

brass wire →

	Steel	Cast iron	Stainless steel	Non-ferrous metal	Aluminium	Softwood	Hardwood
steel wire, crimped	■	■				■	■
steel wire, stainless			■		■		
brass wire				■		■	

Brushes

Introduction & technical information

Easy identification of the best trim material.

The correct choice of trim material is very important in obtaining the best surface finish, because the desired result will only be achieved by correctly matching the trim to the surface material being finished. The illustration below clearly explains the relationships involved in each stage of the process.

E.g.: **Paint removal** from **blank, homogeneous aluminium surfaces** by selection of **crimped, stainless steel wire**

Surface	Desired result	Recommended trim material and its features
Rust/paint removal <ul style="list-style-type: none"> • Non-ferrous metals & aluminium • Stainless steels 	<ul style="list-style-type: none"> • Blank, homogeneous surface • To remove severe contamination • To remove dirt incrustations 	<ul style="list-style-type: none"> • Stainless steel wire, crimped (flexible) • Stainless steel wire, knotted (aggressive) • Stainless steel wire, flat (aggressive)
Deburring, edge rounding <ul style="list-style-type: none"> • Non-ferrous metals & steel • Non-ferrous metals & aluminium • Stainless steels 	<ul style="list-style-type: none"> • Edge rounding, small radius • Medium – aggressive deburring • Medium – aggressive deburring 	<ul style="list-style-type: none"> • Abrasive filament brush (flexible) • Stainless steel wire (flexible) • Steel wire, crimped (flexible)
Cleaning weld seams <ul style="list-style-type: none"> • Non-ferrous metals & aluminium • Stainless steels • Aluminium surfaces 	<ul style="list-style-type: none"> • No material removal from welded seam • No material removal from welded seam • Removal of welding residues & oxide coatings without material removal 	<ul style="list-style-type: none"> • Stainless steel wire, knotted (aggressive) • Steel wire, knotted (aggressive) • Stainless steel wire, crimped (flexible)
Roughening, smoothing <ul style="list-style-type: none"> • All materials • All materials • Stainless steels, INOX, aluminium • Brass, bronze, copper 	<ul style="list-style-type: none"> • Light surface roughening • Blending surfaces • Blending surfaces • Blending surfaces 	<ul style="list-style-type: none"> • Abrasive filament brush, coarse grit 40–120 (flexible) • Abrasive filament brush, fine 120–320 (flexible) • Stainless steel wire, crimped, wire < 0.30 mm (flexible) • Brass wires (flexible)
Sweeping, dedusting <ul style="list-style-type: none"> • Wood • All materials • All materials 	<ul style="list-style-type: none"> • Dust removal • Sealing, stripping • Cleaning 	<ul style="list-style-type: none"> • Fibre (flexibel) • Horse hair (flexible) • Nylon, wire, natural bristle (flexible)
Wood graining <ul style="list-style-type: none"> • Wood • Wood • Wood 	<ul style="list-style-type: none"> • Wood graining • Removing raised wood fibres • Blending/following contours 	<ul style="list-style-type: none"> • Steel wire with brass coating (hard) • Abrasive filament brush (hard) • Abrasive filament brush (fine)

TECHNICAL INFORMATION



Safe and operating speeds

The workplace safety regulations require the maximum safe speed to be observed. Details can be found in the product overview in this catalogue, on the packaging and on the brush itself (see fig.). **The definition of operating speed is based on the peripheral speed and brush diameter.** The ideal operating speed is generally significantly lower than the safe speed.



Operating and clamping width of the brush

The **operating width** describes the contact surface between brush and workpiece. Press the trim together slightly to measure the operating width. The **clamping width** is measured between the washers (see fig. left). **Contact us for more information on the clamping width.**



Brush diameter and trim length

The relationship between the diameter of the brush (brush body) and the length of the trim determines how the brush operates. Generally speaking:

Soft, flexible brushes,
e.g. for finishing structured workpieces or surface cleaning.



More aggressive brushing,
e.g. for deburring or removing impurities.



Ideal position of brush in relation to workpiece

The contract pressure of a brush is defined by factors such as its insertion depth in the workpiece. Our recommendation is 3 times the filament diameter, e.g. 1.0 mm insertion depth for a wire thickness of 0.35 mm. The ideal position also ensures less wear. Our application engineers will be glad to advise.

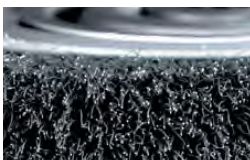

Brush trim density

The trim density is determined by the number of wire tips per surface unit. High trim densities are best for cutting performance and service life (e.g. deburring). Lower trim densities increase brush flexibility and are required for finishing intricately shaped surfaces.

ANY QUESTIONS? We will be glad to help: service@osborn.de

Brushes

Introduction & technical information



Important safety instructions

For **efficient and safe use**, always choose the maximum possible brush diameter that can be fitted to the grinder.

As mentioned in the section on operating speeds, the brush diameter defines the **peripheral speed**. It can also affect brush performance.

The table below provides a summary.

rpm ¹	Brush diameter in mm											
	20	40	50	80	100	125	150	180	200	250	300	350
800				3,35	4,19	5,23	6,28	7,53	8,37	10,47	12,56	14,75
900			2,35	3,77	4,71	5,88	7,06	8,48	9,41	11,77	14,12	16,47
1.150			3,01	4,81	6,01	7,52	9,02	10,83	12,03	15,04	18,04	21,04
1.200	1,25	2,51	3,14	5,02	6,28	7,85	9,41	11,30	12,55	15,69	18,83	21,97
1.400	1,46	2,93	3,66	5,86	7,32	9,15	10,98	13,18	14,64	18,31	21,97	25,63
1.500	1,57	3,14	3,92	6,28	7,85	9,81	11,77	14,13	15,69	19,61	23,54	27,46
1.800	1,88	3,77	4,71	7,54	9,41	11,77	14,12	16,95	18,83	23,54	28,24	32,95
2.000	2,09	4,19	5,23	8,37	10,26	13,08	15,69	18,84	20,92	26,15	31,38	36,61
2.500	2,62	5,23	6,54	10,47	13,08	16,35	19,61	23,55	26,15	32,67	39,23	45,76
2.800	2,93	5,86	7,32	11,72	14,64	18,31	21,97	26,37	29,29	36,61	43,93	51,25
3.000	3,14	6,28	7,85	12,56	15,69	19,62	23,54	28,26	31,38	39,23	47,07	54,92
3.200	3,35	6,70	8,37	13,40	16,74	20,92	25,10	30,14	33,47	41,84	50,12	58,58
3.500	3,66	7,33	9,15	14,65	18,31	22,89	27,46	32,97	36,61	45,76	54,92	64,07
4.000	4,19	8,37	10,46	16,75	20,92	26,16	31,38	37,68	41,84	52,33	62,76	73,22
4.500	4,70	9,42	11,77	18,84	23,54	29,43	35,30	42,40	47,07	58,84	70,61	82,43
5.000	5,23	10,47	13,08	20,93	26,15	32,70	39,23	47,10	52,33	65,38	78,50	
5.400	5,65	11,30	14,12	22,94	28,24	35,31	42,36	50,67	56,48	70,61	84,78	
6.000	6,28	12,56	15,69	25,12	31,38	39,24	47,07	56,52	62,76	78,50		
7.000	7,33	14,66	18,31	29,31	36,61	45,78	54,92	65,94	73,22	91,58		
8.000	8,37	16,75	20,92	33,94	41,48	52,32	62,76	75,36	83,73			
9.000	9,42	18,84	23,54	37,68	47,07	58,86	70,61	84,78	94,20			
10.000	10,47	20,93	26,17	41,86	52,33	65,40	78,50	94,20				
12.500	13,08	26,17	32,71	52,33	65,42	81,75	98,13					
15.000	15,70	31,40	39,25	62,80								
17.500	18,32	36,63	45,79	73,26								
20.000	20,93	41,87	52,33	83,73								
22.500	23,55	47,10	58,88	94,20								
25.000	26,17	52,33	65,42	104,66								

Installation instructions

Please read before fitting the brush.

- The speed of the drive shaft on your machine should not exceed the maximum safe speed of the brush.
- The length of the shaft should be sufficient to ensure a firm fit in the chuck.
- Brushes with a clamping shank can be installed without problems in standard drill chucks or collets.
- The connecting threads on the brushes have flats for simple installation and removal.

Safe peripheral speeds:

Guide values for safe peripheral speeds are, for example, 30-35 m/sec. for brushes with crimped wire, and 18-22 m/sec. for brushes with abrasive filaments and synthetic compound trim materials.

Brushes with knotted wire should be used in angle grinders at max. 85 m/sec., and stationary machines at max. 45 m/sec.



Important:
Hand tools should only be fitted with brushes up to a max. OD of 180 mm.



General safety instructions



Wear protective clothing to protect yourself from injury.



More safety instructions and examples of usage can also be found on the Internet.



For more information*



www.osborn-app.com

* Network charges apply for the use of mobile websites.

Brushes Angle grinder



GENERAL INFORMATION 20

WHEEL BRUSHES 23

CUP BRUSHES 27

BEVEL BRUSHES 33

BRUSHES FOR CORDLESS POWER TOOLS 36



Brushes

Angle grinder



Important user information

Brushes for angle grinders

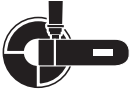

To be noted when selecting brushes and using angle grinders:

1. Typical brush types for angle grinders



Wheel brushes

Available with knotted and crimped wire as well as abrasive filaments.



Cup brushes

Available with knotted and crimped wire, as well as abrasive filaments.



Please note:

When deciding on a suitable diameter for a cup brush, do not forget that it will spread out during operation. The key factor in determining the maximum possible brush diameter is therefore the size of the safety guard.



Bevel brushes

Available with knotted and crimped wire.

2. Determining the operating speed

The maximum operating speed of a brush depends on its diameter. As in the case of a bicycle wheel, the larger it is the fewer turns are needed to cover a particular distance.

The most common speeds are colour-coded to clearly show the differences and for ease of identification:



Diameter:	Ø 115 mm (4 1/2")	Ø 125 mm (5")	Ø 150 mm (6")	Ø 180 mm (7")	Ø 230 mm (9")
Operating speed:	12.500 rpm	11.000 rpm	8.500 rpm	8.500 rpm	6.500 rpm

3. Which brush for which angle grinder?

Brush type & trim	Ø Brush											
	60	65	75	80	90	100	115	120	125	150	178	230
Wheel brush, knotted						115	115		125	150	180	230
Wheel brush, crimped						115	115					
Bevel brush, knotted						115	115		125			
Bevel brush, crimped						115	115					
Cup brush, knotted		115	125	150		180		230				
Cup brush, crimped	115		125	150		150/180			230	230		
Cup brush, abrasive						150*						

* adjustable

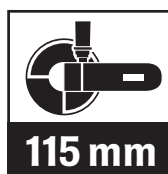

The machine information on the packaging

The machine icon on all Osborn packaging will also show the maximum permitted machine size.



PRODUCT FINDER WELD SEAM CLEANING

Impurities or non-metallic inclusions can occur on the surface of the weld, depending on the welding procedure. Non-metallic inclusions do not adhere to the surface to the extent of the other materials in the weld. If a coating is later applied to the welded part, faults in the coating and corrosion can occur in the area of the inclusions.



The QR code will take you directly to the special page for welding with an easy to use online product finder.

Osborn can provide the appropriate cleaning tool for any welding procedure and type of seam to be finished (root, filler or cover). Brushes are the ideal solution because they do not grind the material, unlike commonly used grinding wheels. Our weld matrix will help you select the right product for your application.

The most common contamination occurring during welding (in order of technique):

	MMA	TIG/MIG/MAG	PLASMA
Slag Residues that occur as the electrodes wear.	Spatter Grinding wheels remove this residue.	Silicates Silicates occur when silicon – present in most steel alloys – burns during the welding process and change to SiO ₂ .	Blue Colour Oxide deposits that form mainly when welding stainless steel.

	MMA	TIG/MIG/MAG	PLASMA
Root/ Hot pass	~ 0,50/0,80 mm 4 - 6 mm Plastic-bonded, knotted wire	4 mm Grinding wheel	~ 0,30 - 0,50 mm 4 mm Plastic-bonded, crimped wire
Fill layer	~ 0,50/0,80 mm 6 - 13 mm Knotted wire	6 - 8 mm Grinding wheel	~ 0,30 - 0,50 mm 13 mm Knotted wire
Cap layer	~ 0,50/0,80 mm 13 mm Knotted wire	Grit 40 - 60 Flap grinding wheel	~ 0,30 - 0,50 mm 6 - 13 mm Knotted wire
Surface	~ 0,50/0,80 mm 13 mm Knotted wire	Grit 40 - 60 Flap grinding wheel	~ 0,30 - 0,50 mm 13 mm Knotted wire

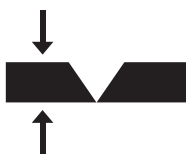

Wall thickness	Round brush Ø
10 mm	100 / 115 mm
15 mm	115 / 125 mm
20 mm	150 mm
25 mm	180 mm
30 mm	180 mm
35 mm	230 mm



You can download a PDF containing a detailed matrix or use the online product finder. Just scan the QR code at the top or enter <http://weldcleaning.osborn.com>.

Brushes

Angle grinder



Important information

Material care

Wire brushes are not cutting tools. They remove residues such as slag, silicates and bluing but leave the original surface structure untouched. That saves time and money!

Flying sparks

Flying sparks are a safety risk in confined spaces such as pipeline installation sites, especially if several people are working together. Brushes generate 95 % less sparks than grinding wheels.

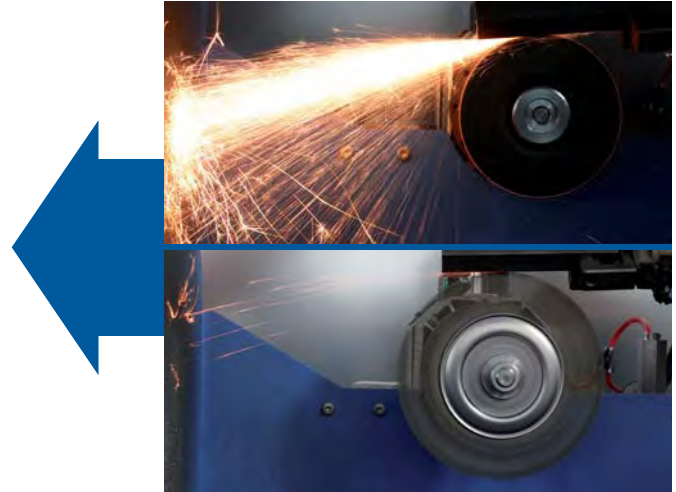

Noise level

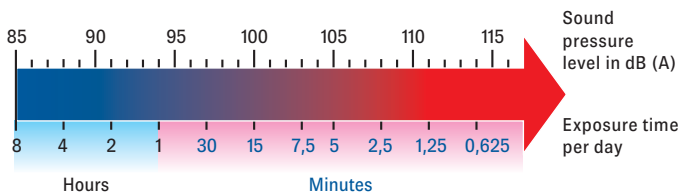

Sound pressure level and daily exposure times for maintaining a daily noise exposure level (Lex), 8 h of 85 dB(A) - upper value

Noise

Studies have shown that the noise level in the metal-working industry is one of the highest compared with other sectors. EU directives specify an average noise level of 85 dB (A) per day. Noise is one of the best known causes of illness.

Noise comparison

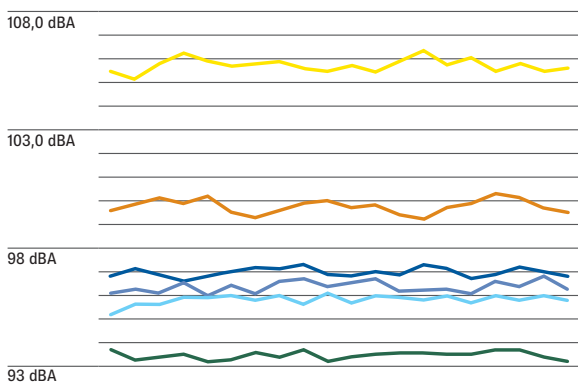

- Cup brush, 60 mm, M14 steel wire, crimped 0.30
- Disc centre 115 x 12 knotted steel wire 0.50
- Disc centre 115 x 6 knotted steel wire 0.50
- Grinding wheels 125 x 6 x 22,23
- Abrasive mop wheel 125 x 22,23 K 80
- Metabo WE14-125 grinder without tool



This diagram shows that wire brushes are an average 6–8 dB (A) quieter than grinding tools. This is a significant reduction and a contribution to occupational safety because a variation of just +/- 3 dB (A) is the equivalent of doubling/halving the noise level.

Brushes Angle grinder

Wheel Brushes

knotted wire



SPECIAL



Wheel brushes for easy installation on angle grinders; for deburring and cleaning weld seams. Industrial grade.

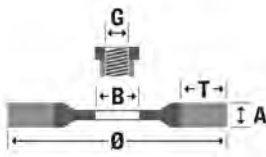

USAGE

115-230

	0,26	0,35	0,50	0,60	0,80
roughening	<input type="checkbox"/>	<input type="checkbox"/>	<input type="checkbox"/>	<input type="checkbox"/>	<input type="checkbox"/>
deburring	<input type="checkbox"/>	<input type="checkbox"/>	<input type="checkbox"/>	<input type="checkbox"/>	<input type="checkbox"/>
edge honing	<input type="checkbox"/>	<input type="checkbox"/>	<input type="checkbox"/>	<input type="checkbox"/>	<input type="checkbox"/>
descaling/paint stripping	<input type="checkbox"/>	<input type="checkbox"/>	<input type="checkbox"/>	<input type="checkbox"/>	<input type="checkbox"/>
slag residue	<input type="checkbox"/>	<input type="checkbox"/>	<input type="checkbox"/>	<input type="checkbox"/>	<input type="checkbox"/>
silicates residue	<input type="checkbox"/>	<input type="checkbox"/>	<input type="checkbox"/>	<input type="checkbox"/>	<input type="checkbox"/>
blue color residue	<input type="checkbox"/>	<input type="checkbox"/>	<input type="checkbox"/>	<input type="checkbox"/>	<input type="checkbox"/>

TRIM AND MATERIAL

Products available with:

Steel wire twist knot →

Stainless steel →

Steel	Cast steel	Stainless steel	Non-ferrous metal	Aluminium	Soft wood	Hard wood
<input checked="" type="checkbox"/>	<input checked="" type="checkbox"/>	<input checked="" type="checkbox"/>	<input type="checkbox"/>	<input type="checkbox"/>	<input type="checkbox"/>	<input type="checkbox"/>

mm								0,35	RRP	0,50	RRP	0,80	RRP
Ø	A	T	B	G	Adapt.	rpm	pcs.	Order-No.	€	Order-No.	€	Order-No.	€
75	12	15	13			20000	12	0002-611 131		0002-611 151			
100	12	20	22,2		F	12500	8	0002-621 131		0002-621 151			
115	12	23	22,2		F	12500	10	0002-631 131		0002-631 151			
115	12	23		M14x2,0		12500	6	0402-631 131		0402-631 151			
115	6	19	22,2		F	12500	10	9502-626 301		9502-626 501			
125	13	28	22,2		F	12500	8	6152-631 131		2202-631 151			
125	13	28		M14x2,0		12500	8	1402-631 131		1402-631 151			
125	6	24	22,2		F	12500	8	9502-626 311		9502-626 251			
150	13	37	22,2		F	12000	5	0002-641 131		0002-641 151		0002-641 181	
178	13	42	22,2		F	10000	6	0002-653 131		0002-653 151		0002-653 181	
178	6	38	22,2		F	12000	12	4602-626 131					
230	6	57	22,2		F	6500	1			4306-026 904			
230	13	58	22,2		F	8500	1			9502-664 151			

mm								0,35	RRP	0,50	RRP	0,50 1.4401	RRP
Ø	A	T	B	G	Adapt.	rpm	pcs.	Order-No.	€	Order-No.	€	Order-No.	€
100	12	20	22,2		F	12500	4			0002-621 351			
115	12	23	22,2		F	12500	4	0002-631 331		0002-631 351			
115	12	23	22,2		F	12500	4					4902-631 351	*
115	12	23		M14x2,0		12500	4	0402-631 331		0402-631 351			
125	6	24	22,2		F	12000	3	4602-626 331		9502-626 651		4902-626 651	*
125	13	28	22,2		F	12500	3	2202-631 331		2202-631 351			
125	13	28	22,2		F	12500	3					4912-631 351	*
125	13	28		M14x2,0		12500	3	1402-631 331		1402-631 351			
150	13	37	22,2		F	12000	3			0002-641 351			
178	13	42	22,2		F	10000	3			0002-653 351			
178	13	42	22,2		F	10000	3					4902-653 351	*
178	6	38	22,2		F	12000	12	4612-626 331					

* TÜV-Certification planned.

Wheel Brushes

knotted wire



PERFECT

Wheel brushes for easy installation on angle grinders; for deburring and cleaning weld seams. Do-it-yourself version.

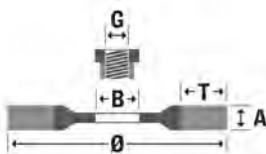

USAGE

115-180

	0,26	0,35	0,50	0,60	0,80
roughening	<input type="checkbox"/>	<input type="checkbox"/>	<input type="checkbox"/>	<input type="checkbox"/>	<input type="checkbox"/>
planing	<input type="checkbox"/>	<input type="checkbox"/>	<input type="checkbox"/>	<input type="checkbox"/>	<input type="checkbox"/>
deburring	<input type="checkbox"/>	<input type="checkbox"/>	<input type="checkbox"/>	<input type="checkbox"/>	<input type="checkbox"/>
edge honing	<input type="checkbox"/>	<input type="checkbox"/>	<input type="checkbox"/>	<input type="checkbox"/>	<input type="checkbox"/>
structuring	<input type="checkbox"/>	<input type="checkbox"/>	<input type="checkbox"/>	<input type="checkbox"/>	<input type="checkbox"/>
descaling/paint stripping	<input type="checkbox"/>	<input type="checkbox"/>	<input type="checkbox"/>	<input type="checkbox"/>	<input type="checkbox"/>
weld seams	<input checked="" type="checkbox"/>	<input checked="" type="checkbox"/>	<input checked="" type="checkbox"/>	<input checked="" type="checkbox"/>	<input checked="" type="checkbox"/>

TRIM AND MATERIAL

Products available with:

Steel wire twist knot →

Steel	Cast steel	Stainless steel	Non-ferrous metal	Aluminium	Soft wood	Hard wood
<input checked="" type="checkbox"/>	<input checked="" type="checkbox"/>	<input type="checkbox"/>	<input type="checkbox"/>	<input type="checkbox"/>	<input type="checkbox"/>	<input type="checkbox"/>

mm								0,35	RRP
Ø	A	T	B	G	Adapt.	rpm	pcs.	Order-No.	€
115	10	20	22,2			12500	10	2008-631 151	
125	12	27	22,2			12500	8	2118-631 151	



Brushes

Angle grinder

Wheel Brushes

knotted Osborn wire



EVOLUTION

Wheel brushes for easy installation on angle grinders; for deburring and cleaning weld seams. Special knotting and hardened wire for industrial applications and long service life.

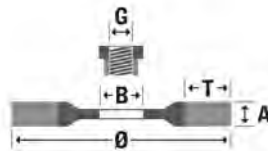

115-180

USAGE

	0,26	0,35	0,50	0,60	0,80
roughening	<input type="checkbox"/>	<input type="checkbox"/>	<input type="checkbox"/>	<input type="checkbox"/>	<input type="checkbox"/>
deburring	<input type="checkbox"/>	<input type="checkbox"/>	<input type="checkbox"/>	<input type="checkbox"/>	<input type="checkbox"/>
edge honing	<input type="checkbox"/>	<input type="checkbox"/>	<input type="checkbox"/>	<input type="checkbox"/>	<input type="checkbox"/>
descaling/paint stripping	<input type="checkbox"/>	<input type="checkbox"/>	<input type="checkbox"/>	<input type="checkbox"/>	<input type="checkbox"/>
slag residue	<input type="checkbox"/>	<input type="checkbox"/>	<input type="checkbox"/>	<input type="checkbox"/>	<input type="checkbox"/>
silicates residue	<input type="checkbox"/>	<input type="checkbox"/>	<input type="checkbox"/>	<input type="checkbox"/>	<input type="checkbox"/>
blue color residue	<input type="checkbox"/>	<input type="checkbox"/>	<input type="checkbox"/>	<input type="checkbox"/>	<input type="checkbox"/>

TRIM AND MATERIAL

Products available with:

Steel wire twist knot →

Stainless steel →

Steel	Cast steel	Stainless steel	Non-ferrous metal	Aluminium	Soft wood	Hard wood
<input checked="" type="checkbox"/>	<input checked="" type="checkbox"/>	<input checked="" type="checkbox"/>	<input type="checkbox"/>	<input type="checkbox"/>	<input type="checkbox"/>	<input type="checkbox"/>

mm									Osborn 0,35	RRP	Osborn 0,50	RRP			
Ø	A	T	B	G	Adapt.	rpm	pcs.	Order-No.	€	Order-No.	€	Order-No.	€	Order-No.	€
75	13	17	1/2"		F	20000	12	9906-026 011		9906-026 012					
100	13	22	5/8"		F	18000	12	9906-026 116		9906-026 117					
100	13	22	7/8"		F	18000	12	9906-026 280		9906-026 281					
115	6	19	7/8"		F	12500	12			2906-026 501					
115	6	19		M14x2,0		12500	12	0002-626 305		0002-626 505					
125	6	24	7/8"		F	12500	12	0002-626 311		0002-626 251					

mm									Osborn 0,50	RRP					
Ø	A	T	B	G	Adapt.	rpm	pcs.	Order-No.	€	Order-No.	€	Order-No.	€	Order-No.	€
115	6	19	7/8"		F	12500	12	0002-626 650							
125	6	24	7/8"		F	12500	12	0002-626 651							

Wheel Brushes

knotted Osborn wire



EVOLUTION

Wheel brushes for easy installation on angle grinders; for deburring and cleaning weld seams. Special knotting and hardened wire for industrial applications and long service life.

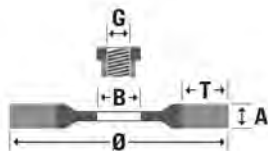

115-180

USAGE

	0,26	0,35	0,50	0,60	0,80
roughening	<input type="checkbox"/>	<input type="checkbox"/>	<input type="checkbox"/>	<input type="checkbox"/>	<input type="checkbox"/>
deburring	<input type="checkbox"/>	<input type="checkbox"/>	<input type="checkbox"/>	<input type="checkbox"/>	<input type="checkbox"/>
edge honing	<input type="checkbox"/>	<input type="checkbox"/>	<input type="checkbox"/>	<input type="checkbox"/>	<input type="checkbox"/>
descaling/paint stripping	<input type="checkbox"/>	<input type="checkbox"/>	<input type="checkbox"/>	<input type="checkbox"/>	<input type="checkbox"/>
slag residue	<input type="checkbox"/>	<input type="checkbox"/>	<input type="checkbox"/>	<input type="checkbox"/>	<input type="checkbox"/>
silicates residue	<input type="checkbox"/>	<input type="checkbox"/>	<input type="checkbox"/>	<input type="checkbox"/>	<input type="checkbox"/>
blue color residue	<input type="checkbox"/>	<input type="checkbox"/>	<input type="checkbox"/>	<input type="checkbox"/>	<input type="checkbox"/>

TRIM AND MATERIAL

Products available with:

Steel wire twist knot →

Stainless steel →

Steel	Cast steel	Stainless steel	Non-ferrous metal	Aluminium	Soft wood	Hard wood
<input checked="" type="checkbox"/>	<input checked="" type="checkbox"/>	<input checked="" type="checkbox"/>	<input type="checkbox"/>	<input type="checkbox"/>	<input type="checkbox"/>	<input type="checkbox"/>

mm									Osborn 0,35	RRP	Osborn 0,50	RRP			
Ø	A	T	B	G	Adapt.	rpm	pcs.	Order-No.	€	Order-No.	€	Order-No.	€	Order-No.	€
150	6	38	7/8"		F	12000	12			9906-026 501					
150	25	38	7/8"		F	12000	12	9906-026 247							
150	6	38		M14x2,0		12000	10			9906-026 500					
150	13	38	7/8"		F	12000	12	9906-026 248							
165	6	29	7/8"		F		12			0002-626 061					
171	6	29	7/8"		F	12000	12			9706-026 904					
178	6	38	22,2		F	12000	12			9906-026 051					
178	6	38		M14x2,0		12000	10			9906-026 053					

Brushes Angle grinder

Wheel Brushes
knotted wire



EVOLUTION



Brushes with special clockwise/anticlockwise knotting for smooth, vibrationfree use.

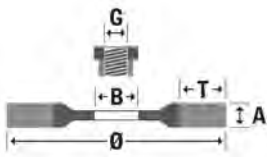

USAGE

115-180

	0,26	0,35	0,50	0,60	0,80
roughening	<input type="checkbox"/>	<input type="checkbox"/>	<input type="checkbox"/>	<input type="checkbox"/>	<input type="checkbox"/>
deburring	<input type="checkbox"/>	<input type="checkbox"/>	<input type="checkbox"/>	<input type="checkbox"/>	<input type="checkbox"/>
edge honing	<input type="checkbox"/>	<input type="checkbox"/>	<input type="checkbox"/>	<input type="checkbox"/>	<input type="checkbox"/>
descaling/paint stripping	<input type="checkbox"/>	<input type="checkbox"/>	<input type="checkbox"/>	<input type="checkbox"/>	<input type="checkbox"/>
slag residue	<input type="checkbox"/>	<input type="checkbox"/>	<input type="checkbox"/>	<input type="checkbox"/>	<input type="checkbox"/>
silicates residue	<input type="checkbox"/>	<input type="checkbox"/>	<input type="checkbox"/>	<input type="checkbox"/>	<input type="checkbox"/>
blue color residue	<input type="checkbox"/>	<input type="checkbox"/>	<input type="checkbox"/>	<input type="checkbox"/>	<input type="checkbox"/>

TRIM AND MATERIAL

Products available with:

Steel wire twist knot → Steel Cast steel Stainless steel Non-ferrous metal Aluminium Soft wood Hard wood

mm						0,35	RRP	0,50	RRP		
Ø	A	T	B	rpm	pcs.	Order-No.	€	Order-No.	€	Order-No.	€
115	12	23	22,2	12500	10	1202-631 131		1202-631 151			
125	13	28	22,2	12500	8	1212-631 131		1212-631 151			
178	13	42	22,2	12500	6	1202-653 131		1202-653 151			

Wheel Brushes
knotted Osborn wire
plasticbonded



EVOLUTION

Non-deforming brushes to remove slag and silicates. Suitable for root and filler welds. Recommended for MMA/manually welded joints with heavier deposits.

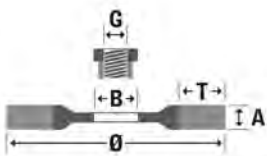

USAGE

125-180

	0,26	0,35	0,50	0,60	0,80
roughening	<input type="checkbox"/>	<input type="checkbox"/>	<input type="checkbox"/>	<input type="checkbox"/>	<input type="checkbox"/>
deburring	<input type="checkbox"/>	<input type="checkbox"/>	<input type="checkbox"/>	<input type="checkbox"/>	<input type="checkbox"/>
edge honing	<input type="checkbox"/>	<input type="checkbox"/>	<input type="checkbox"/>	<input type="checkbox"/>	<input type="checkbox"/>
descaling/paint stripping	<input type="checkbox"/>	<input type="checkbox"/>	<input type="checkbox"/>	<input type="checkbox"/>	<input type="checkbox"/>
slag residue	<input type="checkbox"/>	<input type="checkbox"/>	<input type="checkbox"/>	<input type="checkbox"/>	<input type="checkbox"/>
silicates residue	<input type="checkbox"/>	<input type="checkbox"/>	<input type="checkbox"/>	<input type="checkbox"/>	<input type="checkbox"/>
blue color residue	<input type="checkbox"/>	<input type="checkbox"/>	<input type="checkbox"/>	<input type="checkbox"/>	<input type="checkbox"/>

TRIM AND MATERIAL

Products available with:

Steel wire twist knot → Steel Cast steel Stainless steel Non-ferrous metal Aluminium Soft wood Hard wood

mm						Osborn 0,50	RRP	Osborn 0,50 *	RRP			
Ø	A	T	B	G	rpm	pcs.	Order-No.	€	Order-No.	€	Order-No.	€
115	6	19	22,2		12000	10	5402-921 873		9812-921 873			
125	6	24	22,2		8500	1	9802-921 873		9812-921 873			
178	6	38	22,2		8500	1	9802-921 875		9812-921 875			

* pointed model. Other articles regular.

Brushes

Angle grinder

Wheel Brushes
crimped wire
plasticbonded



EVOLUTION

Non-deforming brushes to remove silicate and welding residues. Recommended for joints welded using TIG/MIG/MAG. Slim type for narrow seams.

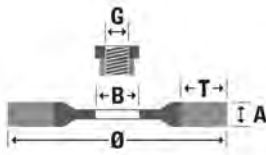

150-180

USAGE

roughening	<input type="checkbox"/>	<input type="checkbox"/>	<input type="checkbox"/>	<input type="checkbox"/>	<input type="checkbox"/>	<input type="checkbox"/>	<input type="checkbox"/>	<input type="checkbox"/>	<input type="checkbox"/>
deburring	<input type="checkbox"/>	<input type="checkbox"/>	<input type="checkbox"/>	<input type="checkbox"/>	<input type="checkbox"/>	<input type="checkbox"/>	<input type="checkbox"/>	<input type="checkbox"/>	<input type="checkbox"/>
edge honing	<input type="checkbox"/>	<input type="checkbox"/>	<input type="checkbox"/>	<input type="checkbox"/>	<input type="checkbox"/>	<input type="checkbox"/>	<input type="checkbox"/>	<input type="checkbox"/>	<input type="checkbox"/>
descaling/paint stripping	<input type="checkbox"/>	<input type="checkbox"/>	<input type="checkbox"/>	<input type="checkbox"/>	<input type="checkbox"/>	<input type="checkbox"/>	<input type="checkbox"/>	<input type="checkbox"/>	<input type="checkbox"/>
slag residue	<input type="checkbox"/>	<input type="checkbox"/>	<input type="checkbox"/>	<input type="checkbox"/>	<input type="checkbox"/>	<input type="checkbox"/>	<input type="checkbox"/>	<input type="checkbox"/>	<input type="checkbox"/>
silicates residue	<input type="checkbox"/>	<input type="checkbox"/>	<input type="checkbox"/>	<input type="checkbox"/>	<input type="checkbox"/>	<input type="checkbox"/>	<input type="checkbox"/>	<input type="checkbox"/>	<input type="checkbox"/>
blue color residue	<input type="checkbox"/>	<input type="checkbox"/>	<input type="checkbox"/>	<input type="checkbox"/>	<input type="checkbox"/>	<input type="checkbox"/>	<input type="checkbox"/>	<input type="checkbox"/>	<input type="checkbox"/>

TRIM AND MATERIAL

Products available with: Steel wire straight →

Steel	<input checked="" type="checkbox"/>	Cast steel	<input type="checkbox"/>	Stainless steel	<input type="checkbox"/>	Non-ferrous metal	<input type="checkbox"/>	Aluminium	<input type="checkbox"/>	Soft wood	<input type="checkbox"/>	Hard wood	<input type="checkbox"/>
-------	-------------------------------------	------------	--------------------------	-----------------	--------------------------	-------------------	--------------------------	-----------	--------------------------	-----------	--------------------------	-----------	--------------------------

mm							0,38	RRP					
Ø	A	T	B	G	rpm	pcs.	Order-No.	€	Order-No.	€	Order-No.	€	
115	5	27		M14x2,0	12000	6	5402-921 051						
125	6	27		M14x2,0	12000	1	4102-921 051						
150	5	29	22,2		8500	12	0002-921 874						
178	5	41	22,2	M14x2,0	8500	10	0002-921 876						
178	5	41	22,2		8500	12	0002-921 875						
178	5	41	22,2	5/8"	8500	10	0002-921 889						
178	3	41	22,2		8000	1	7702-921 875						

Wheel Brushes
crimped wire



SPECIAL



Suitable for an antique finish on wood and light cleaning work on metal surfaces.

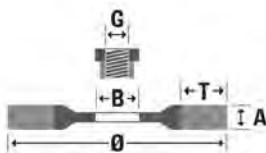

115

USAGE

roughening	<input type="checkbox"/>	<input type="checkbox"/>	<input type="checkbox"/>	<input type="checkbox"/>	<input type="checkbox"/>	<input type="checkbox"/>	<input type="checkbox"/>	<input type="checkbox"/>	<input type="checkbox"/>
planing	<input type="checkbox"/>	<input type="checkbox"/>	<input type="checkbox"/>	<input type="checkbox"/>	<input type="checkbox"/>	<input type="checkbox"/>	<input type="checkbox"/>	<input type="checkbox"/>	<input type="checkbox"/>
deburring	<input type="checkbox"/>	<input type="checkbox"/>	<input type="checkbox"/>	<input type="checkbox"/>	<input type="checkbox"/>	<input type="checkbox"/>	<input type="checkbox"/>	<input type="checkbox"/>	<input type="checkbox"/>
edge honing	<input type="checkbox"/>	<input type="checkbox"/>	<input type="checkbox"/>	<input type="checkbox"/>	<input type="checkbox"/>	<input type="checkbox"/>	<input type="checkbox"/>	<input type="checkbox"/>	<input type="checkbox"/>
structuring	<input type="checkbox"/>	<input type="checkbox"/>	<input type="checkbox"/>	<input type="checkbox"/>	<input type="checkbox"/>	<input type="checkbox"/>	<input type="checkbox"/>	<input type="checkbox"/>	<input type="checkbox"/>
descaling/paint stripping	<input type="checkbox"/>	<input type="checkbox"/>	<input type="checkbox"/>	<input type="checkbox"/>	<input type="checkbox"/>	<input type="checkbox"/>	<input type="checkbox"/>	<input type="checkbox"/>	<input type="checkbox"/>
weld seams	<input type="checkbox"/>	<input type="checkbox"/>	<input type="checkbox"/>	<input type="checkbox"/>	<input type="checkbox"/>	<input type="checkbox"/>	<input type="checkbox"/>	<input type="checkbox"/>	<input type="checkbox"/>

TRIM AND MATERIAL

Products available with: Steel wire straight →

Steel	<input checked="" type="checkbox"/>	Cast steel	<input type="checkbox"/>	Stainless steel	<input type="checkbox"/>	Non-ferrous metal	<input type="checkbox"/>	Aluminium	<input type="checkbox"/>	Soft wood	<input type="checkbox"/>	Hard wood	<input type="checkbox"/>
-------	-------------------------------------	------------	--------------------------	-----------------	--------------------------	-------------------	--------------------------	-----------	--------------------------	-----------	--------------------------	-----------	--------------------------

mm							0,27 cordwire	RRP					
Ø	A	T	G	rpm	pcs.	Order-No.	€	Order-No.	€	Order-No.	€		
115	12	28	M14x2,0	12500	6	2812-522 051							

Brushes Angle grinder

BRUSHES



Wheel Brushes abrasive filament



SPECIAL

Brushes for structuring wood.
Recommended for angle polishers and
angle grinders with adjustable-speed.

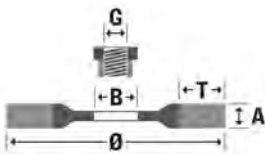

150-180

USAGE

	40/46	60	80	120	180	320	Fibre
roughening	<input checked="" type="checkbox"/>	<input checked="" type="checkbox"/>	<input checked="" type="checkbox"/>	<input type="checkbox"/>	<input type="checkbox"/>	<input type="checkbox"/>	<input type="checkbox"/>
planing	<input type="checkbox"/>	<input type="checkbox"/>	<input type="checkbox"/>	<input type="checkbox"/>	<input type="checkbox"/>	<input type="checkbox"/>	<input type="checkbox"/>
deburring	<input type="checkbox"/>	<input type="checkbox"/>	<input type="checkbox"/>	<input checked="" type="checkbox"/>	<input checked="" type="checkbox"/>	<input checked="" type="checkbox"/>	<input type="checkbox"/>
edge honing	<input type="checkbox"/>	<input type="checkbox"/>	<input type="checkbox"/>	<input checked="" type="checkbox"/>	<input checked="" type="checkbox"/>	<input checked="" type="checkbox"/>	<input type="checkbox"/>
structuring	<input checked="" type="checkbox"/>	<input checked="" type="checkbox"/>	<input checked="" type="checkbox"/>	<input checked="" type="checkbox"/>	<input checked="" type="checkbox"/>	<input checked="" type="checkbox"/>	<input type="checkbox"/>
descaling/paint stripping	<input checked="" type="checkbox"/>	<input checked="" type="checkbox"/>	<input checked="" type="checkbox"/>	<input checked="" type="checkbox"/>	<input checked="" type="checkbox"/>	<input checked="" type="checkbox"/>	<input type="checkbox"/>
weld seams	<input type="checkbox"/>	<input type="checkbox"/>	<input type="checkbox"/>	<input type="checkbox"/>	<input type="checkbox"/>	<input type="checkbox"/>	<input type="checkbox"/>

TRIM AND MATERIAL

Products available with:

Abrasive bristle →

Steel	Cast steel	Stainless steel	Non-ferrous metal	Aluminium	Soft wood	Hard wood
<input type="checkbox"/>	<input type="checkbox"/>	<input type="checkbox"/>	<input type="checkbox"/>	<input type="checkbox"/>	<input checked="" type="checkbox"/>	<input checked="" type="checkbox"/>

mm					Novofil 46	RRP	Novofil 60	RRP	Novofil 80	RRP	
Ø	A	T	G	rpm	pcs.	Order-No.	€	Order-No.	€	Order-No.	€
140	55	30	M14	4500	6	5421-401 913		5411-401 913		5401-401 913	

Cup Brushes knotted wire



SPECIAL

High performance cup brushes for
surface finishing. High cleaning action
from knotted wire.

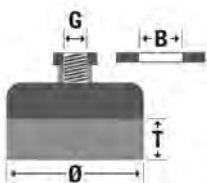

115-125

USAGE

	0,26	0,35	0,50	0,60	0,80
roughening	<input type="checkbox"/>	<input type="checkbox"/>	<input checked="" type="checkbox"/>	<input checked="" type="checkbox"/>	<input checked="" type="checkbox"/>
deburring	<input type="checkbox"/>	<input type="checkbox"/>	<input checked="" type="checkbox"/>	<input checked="" type="checkbox"/>	<input checked="" type="checkbox"/>
edge honing	<input type="checkbox"/>	<input type="checkbox"/>	<input checked="" type="checkbox"/>	<input checked="" type="checkbox"/>	<input checked="" type="checkbox"/>
descaling/paint stripping	<input type="checkbox"/>	<input type="checkbox"/>	<input checked="" type="checkbox"/>	<input checked="" type="checkbox"/>	<input checked="" type="checkbox"/>
slag residue	<input type="checkbox"/>	<input type="checkbox"/>	<input checked="" type="checkbox"/>	<input checked="" type="checkbox"/>	<input checked="" type="checkbox"/>
silicates residue	<input type="checkbox"/>	<input type="checkbox"/>	<input checked="" type="checkbox"/>	<input checked="" type="checkbox"/>	<input checked="" type="checkbox"/>
blue color residue	<input type="checkbox"/>	<input type="checkbox"/>	<input checked="" type="checkbox"/>	<input checked="" type="checkbox"/>	<input checked="" type="checkbox"/>

TRIM AND MATERIAL

Products available with:

Steel wire twist knot →

Stainless steel →

Steel	Cast steel	Stainless steel	Non-ferrous metal	Aluminium	Soft wood	Hard wood
<input checked="" type="checkbox"/>	<input checked="" type="checkbox"/>	<input checked="" type="checkbox"/>	<input type="checkbox"/>	<input type="checkbox"/>	<input type="checkbox"/>	<input type="checkbox"/>

mm					0,35	RRP	0,50	RRP			
Ø	T	B	G	rpm	pcs.	Order-No.	€	Order-No.	€	Order-No.	€
65	20	16		12500	10	1602-608 131		1602-608 151			
65	20		M10x1,25	12500	10	2352-608 131		2352-608 151			
65	20		M10x1,5	12500	10	0102-608 131		0102-608 151			
65	20		M14x2,0	12500	10	0002-608 131		0002-608 151			
65	30		M14x2,0	12500	10	3892-608 131 **					

** extra long trim

mm					0,35	RRP	0,50	RRP	0,50 1,4401	RRP	
Ø	T	B	G	rpm	pcs.	Order-No.	€	Order-No.	€	Order-No.	€
65	20	16		12500	6	1602-608 331					
65	20		M10x1,25	12500	6	2352-608 331		2352-608 351			
65	20		M10x1,5	12500	6	0102-608 331		0102-608 351			
65	20		M14x2,0	12500	6	0002-608 331		0002-608 351		0442-608 351 *	

* TÜV-Certification planned.

Brushes

Angle grinder

Cup Brushes
knotted wire



SPECIAL



High performance cup brushes for surface finishing. High cleaning action from knotted wire. Trim is prevented from splaying by removable support rings. Once the trim is worn, support rings can be removed, so that brush can be fully used.

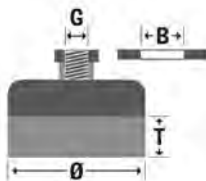

125

USAGE

roughening	<input type="checkbox"/>	0,26
deburring	<input type="checkbox"/>	0,35
edge honing	<input type="checkbox"/>	0,50
descaling/paint stripping	<input type="checkbox"/>	0,60
slag residue	<input type="checkbox"/>	0,80
silicates residue	<input type="checkbox"/>	
blue color residue	<input type="checkbox"/>	

TRIM AND MATERIAL

Products available with: Steel wire twist knot

Steel	<input checked="" type="checkbox"/>
Cast steel	<input checked="" type="checkbox"/>
Stainless steel	<input type="checkbox"/>
Non-ferrous metal	<input type="checkbox"/>
Aluminium	<input type="checkbox"/>
Soft wood	<input type="checkbox"/>
Hard wood	<input type="checkbox"/>

mm					0,35	RRP	0,50	RRP		
Ø	T	G	rpm	pcs.	Order-No.	€	Order-No.	€	Order-No.	€
75	20	M14x2,0	11000	10	9908-608 132		9908-608 152			
75	20	5/8 Zoll	11000	10	9918-608 132		9918-608 152			

Cup Brushes
knotted wire



EVOLUTION

Cup brushes hardened wire for long service life. Recommended for cleaning cover welds and surfaces in the oil and gas industry. Industrial version.

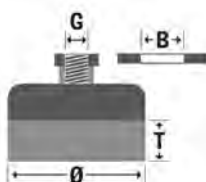

115-150

USAGE

roughening	<input type="checkbox"/>	0,26
planing	<input type="checkbox"/>	0,35
deburring	<input type="checkbox"/>	0,50
edge honing	<input type="checkbox"/>	0,60
structuring	<input type="checkbox"/>	0,80
descaling/paint stripping	<input type="checkbox"/>	
weld seams	<input type="checkbox"/>	

TRIM AND MATERIAL

Products available with: Steel wire twist knot

Steel	<input checked="" type="checkbox"/>
Cast steel	<input checked="" type="checkbox"/>
Stainless steel	<input type="checkbox"/>
Non-ferrous metal	<input type="checkbox"/>
Aluminium	<input type="checkbox"/>
Soft wood	<input type="checkbox"/>
Hard wood	<input type="checkbox"/>

mm						Osborn 0,50	RRP	Osborn 0,80	RRP		
Ø	A	T	G	rpm	pcs.	Order-No.	€	Order-No.	€	Order-No.	€
90	32	65	M14x2,0	7500	6	9906-033 125					
90	32	65	5/8"	7500	6	9906-033 126					
150	45	45	M14x2,0	6000	1	9906-033 016					
150	45	70	M14x2,0	6000	1			9906-033 022			
150	45	70	5/8"	6000	1			9906-033 021			
150	45	75	M14x2,0	6000	1	9906-033 031	*				
150	45	75	5/8"	6000	1	9906-033 030	*				

* two-rowed

Brushes Angle grinder

Cup Brushes

knotted wire



SPECIAL



High performance cup brushes for surface finishing. High cleaning action from knotted wire. Industrial grade.

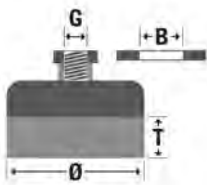

USAGE

150-230

	0,26	0,35	0,50	0,60	0,80
roughening	<input type="checkbox"/>	<input type="checkbox"/>	<input type="checkbox"/>	<input type="checkbox"/>	<input type="checkbox"/>
deburring	<input type="checkbox"/>	<input type="checkbox"/>	<input type="checkbox"/>	<input type="checkbox"/>	<input type="checkbox"/>
edge honing	<input type="checkbox"/>	<input type="checkbox"/>	<input type="checkbox"/>	<input type="checkbox"/>	<input type="checkbox"/>
descaling/paint stripping	<input type="checkbox"/>	<input type="checkbox"/>	<input type="checkbox"/>	<input type="checkbox"/>	<input type="checkbox"/>
slag residue	<input type="checkbox"/>	<input type="checkbox"/>	<input type="checkbox"/>	<input type="checkbox"/>	<input type="checkbox"/>
silicates residue	<input type="checkbox"/>	<input type="checkbox"/>	<input type="checkbox"/>	<input type="checkbox"/>	<input type="checkbox"/>
blue color residue	<input type="checkbox"/>	<input type="checkbox"/>	<input type="checkbox"/>	<input type="checkbox"/>	<input type="checkbox"/>

TRIM AND MATERIAL

Products available with:

Steel wire twist knot →

Stainless steel →

Steel	Cast steel	Stainless steel	Non-ferrous metal	Aluminium	Soft wood	Hard wood
<input checked="" type="checkbox"/>	<input checked="" type="checkbox"/>	<input type="checkbox"/>	<input type="checkbox"/>	<input type="checkbox"/>	<input type="checkbox"/>	<input type="checkbox"/>

mm						0,35	RRP	0,50	RRP	0,80	RRP
Ø	T	B	G	rpm	pcs.	Order-No.	€	Order-No.	€	Order-No.	€
80	20		5/8 Zoll	8500	6	0802-608 133		0802-608 153		0802-608 183	
80	20		M14x2,0	8500	6	0002-608 133		0002-608 153		0002-608 183	
100	20		M14x2,0	8500	3	0002-608 134		0002-608 154		0002-608 184	
100	20		5/8 Zoll	8500	3	0802-608 134		0802-608 154		0802-608 184	
120	20		M14x2,0	6500	4	0002-608 135		0002-608 155		0002-608 185	
120	20		5/8 Zoll	6500	4	0802-608 135		0802-608 155		0802-608 185	

mm						0,35	RRP	0,50	RRP	0,50 1.4401	RRP
Ø	T	B	G	rpm	pcs.	Order-No.	€	Order-No.	€	Order-No.	€
80	20		M14x2,0	8500	3	0002-608 333		0002-608 353		0442-608 353 *	
100	20		M14x2,0	8500	3	0002-608 334		0002-608 354		0442-608 354 *	

* TÜV-Certification planned.

Cup Brushes

knotted wire



PERFECT

Aggressive tools for fast heavy-duty cleaning a brushing of large surfaces. Do-it-yourself version.

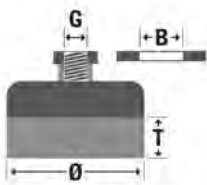

USAGE

150-230

	0,26	0,35	0,50	0,60	0,80
roughening	<input type="checkbox"/>	<input type="checkbox"/>	<input type="checkbox"/>	<input type="checkbox"/>	<input type="checkbox"/>
planing	<input type="checkbox"/>	<input type="checkbox"/>	<input type="checkbox"/>	<input type="checkbox"/>	<input type="checkbox"/>
deburring	<input type="checkbox"/>	<input type="checkbox"/>	<input type="checkbox"/>	<input type="checkbox"/>	<input type="checkbox"/>
edge honing	<input type="checkbox"/>	<input type="checkbox"/>	<input type="checkbox"/>	<input type="checkbox"/>	<input type="checkbox"/>
structuring	<input type="checkbox"/>	<input type="checkbox"/>	<input type="checkbox"/>	<input type="checkbox"/>	<input type="checkbox"/>
descaling/paint stripping	<input type="checkbox"/>	<input type="checkbox"/>	<input type="checkbox"/>	<input type="checkbox"/>	<input type="checkbox"/>
weld seams	<input type="checkbox"/>	<input type="checkbox"/>	<input type="checkbox"/>	<input type="checkbox"/>	<input type="checkbox"/>

TRIM AND MATERIAL

Products available with:

Steel wire twist knot →

Steel	Cast steel	Stainless steel	Non-ferrous metal	Aluminium	Soft wood	Hard wood
<input checked="" type="checkbox"/>	<input checked="" type="checkbox"/>	<input type="checkbox"/>	<input type="checkbox"/>	<input type="checkbox"/>	<input type="checkbox"/>	<input type="checkbox"/>

mm						0,35	RRP	0,50	RRP	0,80	RRP
Ø	T	B	G	rpm	pcs.	Order-No.	€	Order-No.	€	Order-No.	€
65	20		M14x2,0	12500	10	2008-608 131		2008-608 151			
75	27		M14x2,0	11000	10			2008-608 152			
80	22		M14x2,0	8500	10			2008-608 153			
100	24		M14x2,0	8500	5			2008-608 154		2008-608 184	



Brushes

Angle grinder

Cup Brushes
crimped wire



SPECIAL



Material friendly, flexible brush for cleaning, paint stripping and descaling of surfaces. Industrial grade.

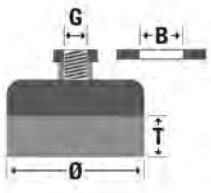

115-125

USAGE

roughening	<input type="checkbox"/>	0.26
deburring	<input type="checkbox"/>	0.35
edge honing	<input type="checkbox"/>	0.50
descaling/paint stripping	<input type="checkbox"/>	0.60
slag residue	<input type="checkbox"/>	0.80
silicates residue	<input type="checkbox"/>	
blue color residue	<input type="checkbox"/>	

TRIM AND MATERIAL

Products available with:

Steel wire crimped	Steel	Cast steel	Stainless steel	Non-ferrous metal	Aluminium	Soft wood	Hard wood
Stainless steel							
Brass wire							

mm						0,20	RRP	0,30	RRP	0,30	RRP
Ø	T	B	G	rpm	pcs.	Order-No.	€	Order-No.	€	Order-No.	€
60	21	16		12500	10			1602-613 161			
60	21	16		12500	4					1602-613 361	
60	21		M10x1,25	12500	10	5262-613 141					
60	21		M10x1,5	12500	10	0102-613 141		0102-613 161			
60	21		M14x2,0	12500	10	0002-613 141		0002-613 161			
60	21		M14x2,0	12500	4					0002-613 361	
75	23	16		12500	10	1602-613 142		1602-613 162			
75	23	16		12500	3					1602-613 362	
75	23		M10x1,25	12500	10	5652-613 142		5652-613 162			
75	23		M10x1,5	12500	10	0102-613 142		0102-613 162			
75	23		M14x2,0	12500	10	0002-613 142		0002-613 162			
75	23		M14x2,0	12500	4					0002-613 362	
75	23		5,8 Zoll	12500	10	0802-613 142		0802-613 162			
75	23		5,8 Zoll	12500	4					0802-613 362	

mm						0,30	RRP	0,30	RRP	0,30	RRP
Ø	T	B	G	rpm	pcs.	Order-No.	€	Order-No.	€	Order-No.	€
60	21		M10x1,25	12500	10			4912-613 561	*		
60	21		M14x2,0	12500	4	0442-613 361	*				
60	21		M14x2,0	12500	10			4902-613 561	*		
75	25		M14x2,0	12500	4	0442-613 362	*				
75	25		M14x2,0	12500	10			4902-613 562	*		

* TÜV-Certification planned.

Cup Brushes
crimped wire



SPECIAL



Material friendly, flexible brush for cleaning, paint stripping and descaling of surfaces. Industrial grade.

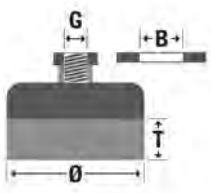

150-230

USAGE

roughening	<input type="checkbox"/>	0.26
deburring	<input type="checkbox"/>	0.35
edge honing	<input type="checkbox"/>	0.50
descaling/paint stripping	<input type="checkbox"/>	0.60
slag residue	<input type="checkbox"/>	0.80
silicates residue	<input type="checkbox"/>	
blue color residue	<input type="checkbox"/>	

TRIM AND MATERIAL

Products available with:

Steel wire crimped	Steel	Cast steel	Stainless steel	Non-ferrous metal	Aluminium	Soft wood	Hard wood
Stainless steel							
Brass wire							

mm						0,20	RRP	0,30	RRP	0,50	RRP
Ø	T	B	G	rpm	pcs.	Order-No.	€	Order-No.	€	Order-No.	€
80	30		M14x2,0	8500	5	0002-613 143		0002-613 163			
80	25		5/8 Zoll	8500	5	0802-613 143		0802-613 163			
80	25		M14x2,0	8500	5					0002-613 193	
100	30		M14x2,0	8500	3	0002-613 144				0002-613 194	
100	30		M14x2,0	8500	4			0002-613 164			
100	30		5/8 Zoll	8500	3	0802-613 144		0802-613 164		0802-613 194	
125	30		M14x2,0	6500	4	0002-613 145		0002-613 165		0002-613 195	
125	30		5/8 Zoll	6500	4			0802-613 165		0802-613 195	
150	40		M14x2,0	4500	3	0002-613 146		0002-613 166		0002-613 196	
150	40		5/8 Zoll	4500	3	0802-613 146		0802-613 166		0802-613 196	

mm						0,30	RRP	0,30	RRP	0,30	RRP
Ø	T	B	G	rpm	pcs.	Order-No.	€	Order-No.	€	Order-No.	€
80	25		M14x2,0	8500	4	0002-613 363		0442-613 363	*		
80	25		M14x2,0	8500	5					4902-613 563	*
80	25		5/8 Zoll	8500	4	0802-613 363					
100	25		M14x2,0	8500	3	0002-613 364		0442-613 364	*		
100	30		M14x2,0	8500	4					4912-613 564	*
100	30		5/8 Zoll	8500	3	0802-613 364					
125	30		5/8 Zoll	6500	2	0802-613 365					
125	30		M14x2,0	6500	2	0002-613 365		0442-613 365	*		

* TÜV-Certification planned.

Brushes Angle grinder



Cup Brushes
crimped wire



PERFECT

Material friendly, flexible brush for cleaning, paint stripping and descaling of surfaces. Do-it-yourself version.

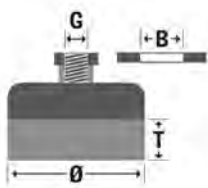

150-180

USAGE

	0,15	0,25	0,27	0,30	0,35	0,40	0,50
roughening	<input type="checkbox"/>	<input type="checkbox"/>	<input type="checkbox"/>	<input type="checkbox"/>	<input type="checkbox"/>	<input type="checkbox"/>	<input type="checkbox"/>
planing	<input type="checkbox"/>	<input type="checkbox"/>	<input type="checkbox"/>	<input type="checkbox"/>	<input type="checkbox"/>	<input type="checkbox"/>	<input type="checkbox"/>
deburring	<input type="checkbox"/>	<input type="checkbox"/>	<input type="checkbox"/>	<input type="checkbox"/>	<input type="checkbox"/>	<input type="checkbox"/>	<input type="checkbox"/>
edge honing	<input type="checkbox"/>	<input type="checkbox"/>	<input type="checkbox"/>	<input type="checkbox"/>	<input type="checkbox"/>	<input type="checkbox"/>	<input type="checkbox"/>
structuring	<input type="checkbox"/>	<input type="checkbox"/>	<input type="checkbox"/>	<input type="checkbox"/>	<input type="checkbox"/>	<input type="checkbox"/>	<input type="checkbox"/>
descaling/paint stripping	<input type="checkbox"/>	<input type="checkbox"/>	<input type="checkbox"/>	<input type="checkbox"/>	<input type="checkbox"/>	<input type="checkbox"/>	<input type="checkbox"/>
weld seams	<input type="checkbox"/>	<input type="checkbox"/>	<input type="checkbox"/>	<input type="checkbox"/>	<input type="checkbox"/>	<input type="checkbox"/>	<input type="checkbox"/>

TRIM AND MATERIAL

Products available with: Steel wire straight →

Steel	Cast steel	Stainless steel	Non-ferrous metal	Aluminium	Soft wood	Hard wood
<input checked="" type="checkbox"/>	<input type="checkbox"/>	<input type="checkbox"/>	<input type="checkbox"/>	<input type="checkbox"/>	<input type="checkbox"/>	<input type="checkbox"/>

mm					0,30	RRP	0,30 brass-coated	RRP				
Ø	A	T	B	G	rpm	pcs.	Order-No.	€	Order-No.	€	Order-No.	€
60		18			12500	10	2008-613 161		2008-613 061			
75		25			12500	10	2008-613 162		2008-613 062			
80		25			8500	10	2008-613 163		2008-613 063			
100		25			8500	5	2008-613 164		2008-613 064			
125		30			6500	5	2008-613 165		2008-613 065			



Cup Brushes Longlife
crimped wire



EVOLUTION



Material friendly. Soft cleaning brushes for surface finishing. Special long-life wire for very long service life and reduced wire breakage.

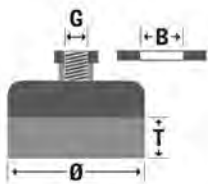

115-230

USAGE

	0,26	0,35	0,50	0,60	0,80
roughening	<input type="checkbox"/>	<input type="checkbox"/>	<input type="checkbox"/>	<input type="checkbox"/>	<input type="checkbox"/>
deburring	<input type="checkbox"/>	<input type="checkbox"/>	<input type="checkbox"/>	<input type="checkbox"/>	<input type="checkbox"/>
edge honing	<input type="checkbox"/>	<input type="checkbox"/>	<input type="checkbox"/>	<input type="checkbox"/>	<input type="checkbox"/>
descaling/paint stripping	<input type="checkbox"/>	<input type="checkbox"/>	<input type="checkbox"/>	<input type="checkbox"/>	<input type="checkbox"/>
slag residue	<input type="checkbox"/>	<input type="checkbox"/>	<input type="checkbox"/>	<input type="checkbox"/>	<input type="checkbox"/>
silicates residue	<input type="checkbox"/>	<input type="checkbox"/>	<input type="checkbox"/>	<input type="checkbox"/>	<input type="checkbox"/>
blue color residue	<input type="checkbox"/>	<input type="checkbox"/>	<input type="checkbox"/>	<input type="checkbox"/>	<input type="checkbox"/>

TRIM AND MATERIAL

Products available with: Steel wire straight →

Steel	Cast steel	Stainless steel	Non-ferrous metal	Aluminium	Soft wood	Hard wood
<input checked="" type="checkbox"/>	<input type="checkbox"/>	<input type="checkbox"/>	<input type="checkbox"/>	<input type="checkbox"/>	<input type="checkbox"/>	<input type="checkbox"/>

mm					Longlife 0,30	RRP				
Ø	T	G	rpm	pcs.	Order-No.	€	Order-No.	€	Order-No.	€
60	20	M14x2,0	12500	10	3902-613 161					
75	25	M14x2,0	12500	10	3912-613 163					
80	25	M14x2,0	12500	5	3902-613 163					
100	22	M14x2,0	8500	4	3902-613 164					

Brushes

Angle grinder

Cup Brushes
abrasive filament



SPECIAL

Paint stripping, deburring and cleaning of metal and wooden surfaces.

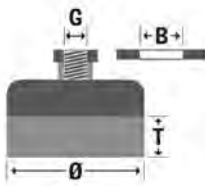

150

USAGE

roughening	<input type="checkbox"/>	0.26
deburring	<input checked="" type="checkbox"/>	0.35
edge honing	<input checked="" type="checkbox"/>	0.50
descaling/paint stripping	<input checked="" type="checkbox"/>	0.60
slag residue	<input checked="" type="checkbox"/>	0.80
silicates residue	<input type="checkbox"/>	
blue color residue	<input type="checkbox"/>	

TRIM AND MATERIAL

Products available with:

Abrasive bristle → Steel Cast steel Stainless steel Non-ferrous metal Aluminium Soft wood Hard wood

mm						Novofil 80	RRP	Novofil 120	RRP	Novofil 180	RRP
Ø	T	B	G	rpm	pcs.	Order-No.	€	Order-No.	€	Order-No.	€
100	25	22,2		8500	3	8812-607 914		2312-607 914		1802-607 914	
100	25		M14x2,0	8500	3	6402-608 914		6412-608 914		1802-608 914	

Cup Brushes
abrasive filament



SPECIAL

Particularly suitable for finishing or denibbing of wooden surfaces.

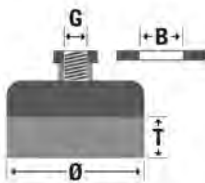

150-180

USAGE

roughening	<input checked="" type="checkbox"/>	40/46
planing	<input checked="" type="checkbox"/>	60
deburring	<input checked="" type="checkbox"/>	80
edge honing	<input checked="" type="checkbox"/>	120
structuring	<input checked="" type="checkbox"/>	180
descaling/paint stripping	<input checked="" type="checkbox"/>	320
weld seams	<input checked="" type="checkbox"/>	Fibre

TRIM AND MATERIAL

Products available with:

Abrasive bristle → Steel Cast steel Stainless steel Non-ferrous metal Aluminium Soft wood Hard wood

mm						Novofil 46	RRP	Novofil 60	RRP	Novofil 80	RRP
Ø	A	T	G	rpm	pcs.	Order-No.	€	Order-No.	€	Order-No.	€
130	70	50	M14x2,0	2500	4	9301-614 916		9311-614 916		9321-614 916	

mm						Novofil 120	RRP				
Ø	A	T	G	rpm	pcs.	Order-No.	€	Order-No.	€	Order-No.	€
130	70	50	M14x2,0	2500	4	9331-614 916					

Brushes Angle grinder

Bevel Brushes

knotted wire



SPECIAL



Particularly suitable for processing inaccessible areas e.g. angles, edges or corners.

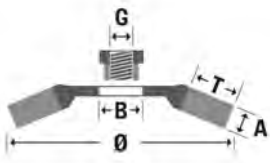

115-125

USAGE

	0,26	0,35	0,50	0,60	0,80
roughening	<input type="checkbox"/>	<input type="checkbox"/>	<input type="checkbox"/>	<input type="checkbox"/>	<input type="checkbox"/>
deburring	<input type="checkbox"/>	<input type="checkbox"/>	<input type="checkbox"/>	<input type="checkbox"/>	<input type="checkbox"/>
edge honing	<input type="checkbox"/>	<input type="checkbox"/>	<input type="checkbox"/>	<input type="checkbox"/>	<input type="checkbox"/>
descaling/paint stripping	<input type="checkbox"/>	<input type="checkbox"/>	<input type="checkbox"/>	<input type="checkbox"/>	<input type="checkbox"/>
slag residue	<input type="checkbox"/>	<input type="checkbox"/>	<input type="checkbox"/>	<input type="checkbox"/>	<input type="checkbox"/>
silicates residue	<input type="checkbox"/>	<input type="checkbox"/>	<input type="checkbox"/>	<input type="checkbox"/>	<input type="checkbox"/>
blue color residue	<input type="checkbox"/>	<input type="checkbox"/>	<input type="checkbox"/>	<input type="checkbox"/>	<input type="checkbox"/>

TRIM AND MATERIAL

Products available with:

Steel wire twist knot →

Stainless steel →

Steel	Cast steel	Stainless steel	Non-ferrous metal	Aluminium	Soft wood	Hard wood
<input checked="" type="checkbox"/>	<input checked="" type="checkbox"/>	<input checked="" type="checkbox"/>	<input type="checkbox"/>	<input type="checkbox"/>	<input type="checkbox"/>	<input type="checkbox"/>

mm							0,35 18 knots	RRP	0,50 18 knots	RRP		
Ø	A	T	B	G	rpm	pcs.	Order-No.	€	Order-No.	€	Order-No.	€
100	13	22	16		12500	10			1602-622 151			
100	13	22		M10x1,25	12500	10	4802-622 131 *		2352-622 151			
100	13	22		M10x1,5	12500	10	0102-622 131		0102-622 151			
100	13	22		M14x2,0	12500	10	0002-622 131		0002-622 151			
115	15	20	16		12500	10			1602-632 151			
115	15	20		M14x2,0	12500	10	0002-632 131		0002-632 151			
115	15	20		5/8 Zoll	12500	10	0802-632 131		0802-632 151			
125	15	23		M14x2,0	12500	10	3602-632 131		2902-632 151			

* TÜV-Certification planned.

mm							0,35 22 knots	RRP	0,50 22 knots	RRP		
Ø	A	T	B	G	rpm	pcs.	Order-No.	€	Order-No.	€	Order-No.	€
100	13	22		M14x2,0	12500	10	0002-623 131		0002-623 151			

mm							0,35 18 knots	RRP	0,50 18 knots	RRP	0,50 1.4401	RRP
Ø	A	T	B	G	rpm	pcs.	Order-No.	€	Order-No.	€	Order-No.	€
100	13	22		M10x1,25	12500	5	4802-622 331		2352-622 351			
100	13	22		M10x1,5	12500	5	0102-622 331		0102-622 351			
100	13	22		M14x2,0	12500	5	0002-622 331		0002-622 351		0442-622 351 *	
115	15	20		M14x2,0	12500	5	0002-632 331		0002-632 351		0442-632 351 *	
115	15	20		5/8 Zoll	12500	5	0802-632 331		0802-632 351			
125	15	23		M14x2,0	12500	10	3602-632 331		3602-632 351			

* TÜV-Certification planned.

mm							0,35 22 knots	RRP	0,50 22 knots	RRP		
Ø	A	T	B	G	rpm	pcs.	Order-No.	€	Order-No.	€	Order-No.	€
100	13	22		M14x2,0	12500	5	0002-623 331		0002-623 351			

Bevel Brushes

knotted wire



PERFECT

The ideal shape for brushing hard-to-reach areas. Multi-purpose brushes for light and medium cleaning jobs.

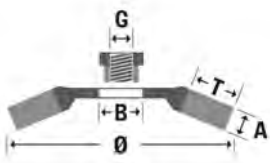

115-125

USAGE

	0,26	0,35	0,50	0,60	0,80
roughening	<input type="checkbox"/>	<input type="checkbox"/>	<input type="checkbox"/>	<input type="checkbox"/>	<input type="checkbox"/>
planing	<input type="checkbox"/>	<input type="checkbox"/>	<input type="checkbox"/>	<input type="checkbox"/>	<input type="checkbox"/>
deburring	<input type="checkbox"/>	<input type="checkbox"/>	<input type="checkbox"/>	<input type="checkbox"/>	<input type="checkbox"/>
edge honing	<input type="checkbox"/>	<input type="checkbox"/>	<input type="checkbox"/>	<input type="checkbox"/>	<input type="checkbox"/>
structuring	<input type="checkbox"/>	<input type="checkbox"/>	<input type="checkbox"/>	<input type="checkbox"/>	<input type="checkbox"/>
descaling/paint stripping	<input type="checkbox"/>	<input type="checkbox"/>	<input type="checkbox"/>	<input type="checkbox"/>	<input type="checkbox"/>
weld seams	<input type="checkbox"/>	<input type="checkbox"/>	<input type="checkbox"/>	<input type="checkbox"/>	<input type="checkbox"/>

TRIM AND MATERIAL

Products available with:

Steel wire twist knot →

Steel	Cast steel	Stainless steel	Non-ferrous metal	Aluminium	Soft wood	Hard wood
<input checked="" type="checkbox"/>	<input checked="" type="checkbox"/>	<input type="checkbox"/>	<input type="checkbox"/>	<input type="checkbox"/>	<input type="checkbox"/>	<input type="checkbox"/>

mm							0,50	RRP				
Ø	A	T	B	G	rpm	pcs.	Order-No.	€	Order-No.	€	Order-No.	€
100	13	22		M14x2,0	12500	8	2008-622 151					



Brushes

Angle grinder

Bevel Brushes
crimped wire



SPECIAL



Particularly suitable for processing inaccessible areas e.g. angles, edges or corners.

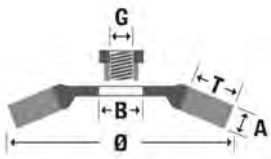

USAGE

115-125

roughening	<input type="checkbox"/>	<input type="checkbox"/>	<input type="checkbox"/>	<input type="checkbox"/>	<input type="checkbox"/>	<input type="checkbox"/>	<input type="checkbox"/>
deburring	<input type="checkbox"/>	<input type="checkbox"/>	<input type="checkbox"/>	<input type="checkbox"/>	<input type="checkbox"/>	<input type="checkbox"/>	<input type="checkbox"/>
edge honing	<input type="checkbox"/>	<input type="checkbox"/>	<input type="checkbox"/>	<input type="checkbox"/>	<input type="checkbox"/>	<input type="checkbox"/>	<input type="checkbox"/>
descaling/paint stripping	<input type="checkbox"/>	<input type="checkbox"/>	<input type="checkbox"/>	<input type="checkbox"/>	<input type="checkbox"/>	<input type="checkbox"/>	<input type="checkbox"/>
slag residue	<input type="checkbox"/>	<input type="checkbox"/>	<input type="checkbox"/>	<input type="checkbox"/>	<input type="checkbox"/>	<input type="checkbox"/>	<input type="checkbox"/>
silicates residue	<input type="checkbox"/>	<input type="checkbox"/>	<input type="checkbox"/>	<input type="checkbox"/>	<input type="checkbox"/>	<input type="checkbox"/>	<input type="checkbox"/>
blue color residue	<input type="checkbox"/>	<input type="checkbox"/>	<input type="checkbox"/>	<input type="checkbox"/>	<input type="checkbox"/>	<input type="checkbox"/>	<input type="checkbox"/>

TRIM AND MATERIAL

Products available with:

Steel wire crimped → Steel Cast steel Stainless steel Non-ferrous metal Aluminium Soft wood Hard wood

Stainless steel → Steel Cast steel Stainless steel Non-ferrous metal Aluminium Soft wood Hard wood

mm							0,30	RRP	0,30 brass-coated	RRP		
Ø	A	T	B	G	rpm	pcs.	Order-No.	€	Order-No.	€	Order-No.	€
100	20	20		M10x1,25	12500	10	2352-512 162					
100	20	10		M10x1,25	12500	10	2352-512 161					
100	20	20		M10x1,5	12500	10	0102-512 162		0002-512 062			
100	20	20		M10x1,5	12500	10	0102-512 161					
100	10	20		M14x2,0	12500	10	0002-512 162		0002-512 061			
100	10	20		M14x2,0	12500	10	0002-512 161					
125	10	25		M14x2,0	12500	10	0002-514 161					

mm							0,20	RRP	0,30	RRP	0,30 1.4401	RRP
Ø	A	T	B	G	rpm	pcs.	Order-No.	€	Order-No.	€	Order-No.	€
100	20	20		M10x1,25	12500	5	2352-512 342		2352-512 362			
100	20	20		M10x1,5	12500	5	0102-512 342		0102-512 362			
100	20	20		M14x2,0	12500	5	0002-512 342		0002-512 362			
100	10	20		M14x2,0	12500	5			0002-512 361			
125	10	25		M14x2,0	12500	5	0002-514 341		0002-514 361		0442-514 361	

Bevel Brushes
crimped wire



PERFECT

The ideal shape for brushing hard-to-reach areas. Multi-purpose brushes for light and medium cleaning jobs.

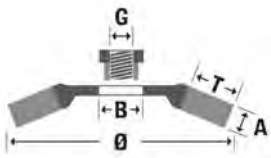

USAGE

125

roughening	<input type="checkbox"/>	<input type="checkbox"/>	<input type="checkbox"/>	<input type="checkbox"/>	<input type="checkbox"/>	<input type="checkbox"/>	<input type="checkbox"/>
planing	<input type="checkbox"/>	<input type="checkbox"/>	<input type="checkbox"/>	<input type="checkbox"/>	<input type="checkbox"/>	<input type="checkbox"/>	<input type="checkbox"/>
deburring	<input type="checkbox"/>	<input type="checkbox"/>	<input type="checkbox"/>	<input type="checkbox"/>	<input type="checkbox"/>	<input type="checkbox"/>	<input type="checkbox"/>
edge honing	<input type="checkbox"/>	<input type="checkbox"/>	<input type="checkbox"/>	<input type="checkbox"/>	<input type="checkbox"/>	<input type="checkbox"/>	<input type="checkbox"/>
structuring	<input type="checkbox"/>	<input type="checkbox"/>	<input type="checkbox"/>	<input type="checkbox"/>	<input type="checkbox"/>	<input type="checkbox"/>	<input type="checkbox"/>
descaling/paint stripping	<input type="checkbox"/>	<input type="checkbox"/>	<input type="checkbox"/>	<input type="checkbox"/>	<input type="checkbox"/>	<input type="checkbox"/>	<input type="checkbox"/>
weld seams	<input type="checkbox"/>	<input type="checkbox"/>	<input type="checkbox"/>	<input type="checkbox"/>	<input type="checkbox"/>	<input type="checkbox"/>	<input type="checkbox"/>

TRIM AND MATERIAL

Products available with:

Steel wire straight → Steel Cast steel Stainless steel Non-ferrous metal Aluminium Soft wood Hard wood

mm							0,30 brass-coated	RRP	0,30	RRP		
Ø	A	T	B	G	rpm	pcs.	Order-No.	€	Order-No.	€	Order-No.	€
100	10	20		M14x2,0	12500	10	2008-512 061		2008-512 161			



Brushes Angle grinder



F-Adapter

Inch		pcs.	Order-No.	RRP			
Inner Ø	Outer Ø			€	Order-No.	€	Order-No.
3/8"	5/8"	1	0003-000 222				
1/2"	5/8"	1	0003-000 223				
3/8"	7/8"	1	0003-000 242				
7/8"	1/2"	1	0003-000 243				
7/8"	5/8"	1	0003-000 244				

For reduction of arbor holes.

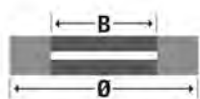

Brushes

Angle grinder

CORDLESS IS KING



More power, longer battery life and no cables: the new generation of cordless power tools, make work easy, even if there is no electricity socket available. Battery life and the actual performance of these tools, has made a huge leap in recent years. Cordless power tools are now an alternative for a whole range of users. Whether on construction sites, or for plumbing, HVAC, janitor services, firefighting, road service and other mobile units, cordless power tools are now considered an essential piece of equipment.



Why special tools?

Cordless power tools are commonly used by mobile services, where not the full range of accessories is available. Users therefore need universal tools which can tackle a variety of tasks on different materials. By this the amount of accessories to be carried along on a construction site can be reduced when steel, stainless steel and wood need to be worked on.

Commonly cordless angle grinders run with a 30% reduced working speed compared to usual angle grinders. Having specifically developed accessories for cordless power tools in use means that the perfect result of brushes, grinding- or cutting discs can be reached by a speed of 7,000 to 8,000 rpm. Osborn Brushes are reduced in weight and therefore prolong the battery life between recharges by 20–25%.

Advantages



- Low weight
- Precise Working
- Multifunctional
- Easy to handle
- Reduced imbalance and vibration
- Longer battery life (20–25%)
- Fewer charging cycles
- Universal usage on all materials
- Can be used for different materials

WE MAKE IT EASY FOR YOU!

OSBORN has developed accessories which are flexible in use, light weight, easy to handle and assure highest precision.

The end result will meet all your expectations and fulfill all aspects of work safety. This is the only way to work effectively and get the best out of your cordless power tool.

Brushes

Angle grinder

BRUSHES



Cup Brushes

crimped wire



Suitable for:
Steel, stainless steel, brass, wood

Cleaning, satinising, flattening and degreasing

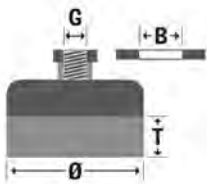

mm					0,30	RRP				
Ø	T	G	rpm	pcs.	Order-No.	€	Order-No.	€	Order-No.	€
60	21	M14x2,0	12500	5	6912-613 561					

Developed for usage on cordless power tools!

Cup Brushes

abrasive nylon



Universal cleaningbrush, reduced weight, with SIC abrasive nylon to process large surfaces.

Suitable for:
Steel, stainless steel, non-ferrous, aluminum, brass, wood

Deburring, paint stripping, cleaning, satinising, degreasing

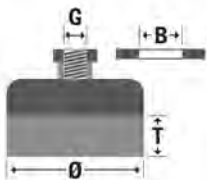

mm					grit 80	RRP				
Ø	T	G	rpm	pcs.	Order-No.	€	Order-No.	€	Order-No.	€
60	21	M14x2,0	12500	5	6912-613 891					

Developed for usage on cordless power tools!

Brushes

Angle grinder



Universal cleaningbrush, reduced weight, with SIC abrasive nylon to process inaccessible areas like edges, angles, corners and cleaning MIG/MAG/TIG weld seams.

Suitable for:
Steel, stainless steel, non-ferrous, aluminum, brass, wood

Deburring, paint stripping, cleaning, satinising, degreasing

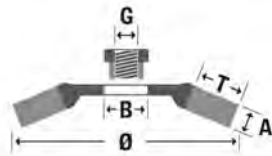

mm							grit 80	RRP				
Ø	A	T	B	G	rpm	pcs.	Order-No.	€	Order-No.	€	Order-No.	€
100		20		M14x2,0	12500	5	6912-622 891					



Please note:

Find polishing and satinising accessories for cordless power tools in chapter Polishing/Satinising on page 95 and 104.

Brushes Power drill

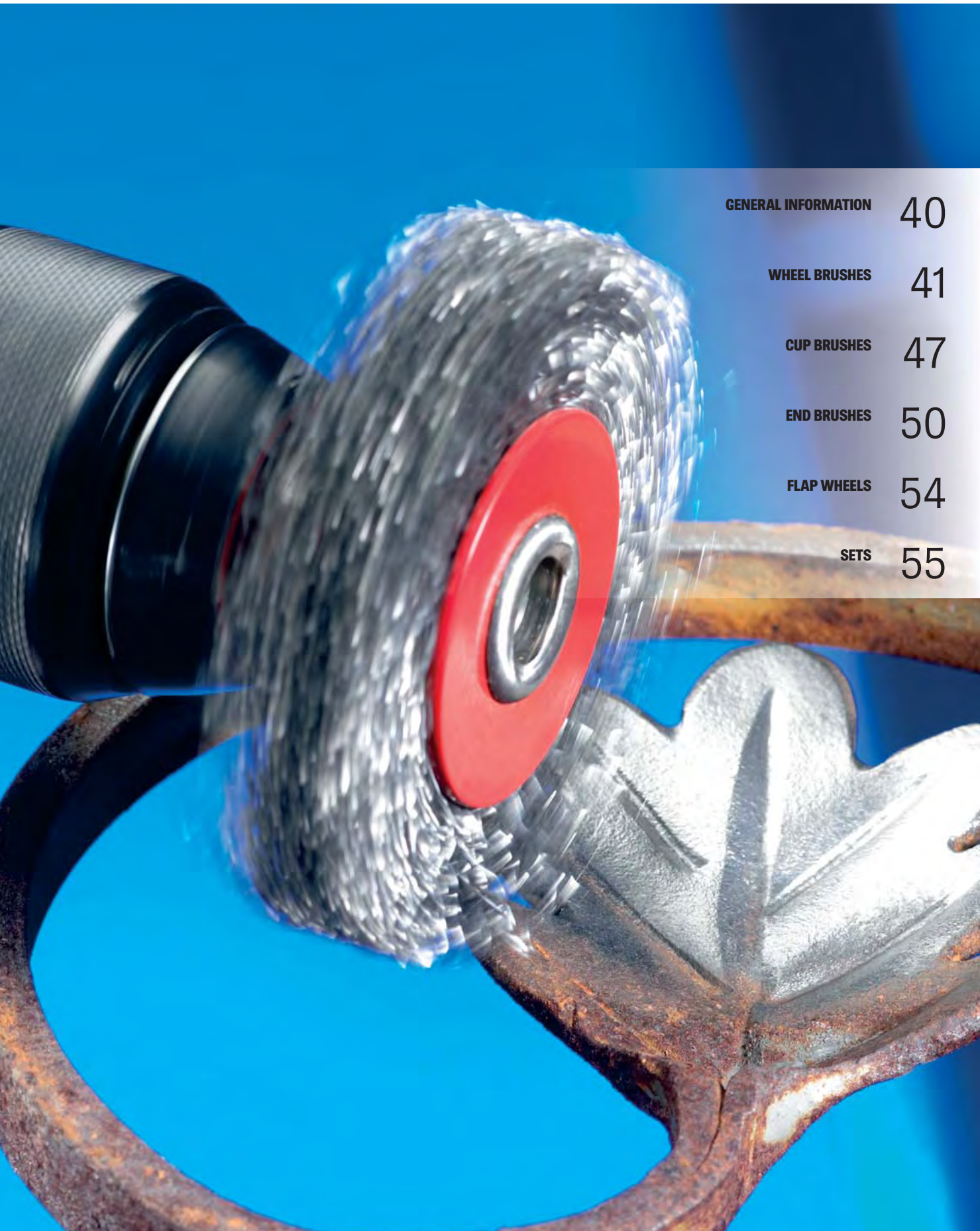

GENERAL INFORMATION 40

WHEEL BRUSHES 41

CUP BRUSHES 47

END BRUSHES 50

FLAP WHEELS 54

SETS 55

Brushes

Power drill



Important user information

Brushes for power drills



To be noted when selecting brushes and using power drills:

1. General user information

The brushes on the following pages are suitable for all brands of power drills. It does not matter whether you are using a 1- or 2-speed machine or a percussion drill.

The recommended speed is approx. 1,500 - 3,500 rpm.

2. Typical brush types for power drills



Wheel brushes

Available with knotted and crimped wire, as well as abrasive filaments or plastic bonded wires.



Cup brushes

Available with knotted and crimped wire, as well as abrasive filaments and plastic bonded wires.



End brushes

Available with crimped wire, abrasive filaments and plastic bonded wires.

Please note:

Cup and end brushes spread during operation.



Flap wheel brushes

Available with crimped wire, abrasive filaments or Tampico fibre.



Tube & internal brushes

All details can be found in the chapter on internal finishing.

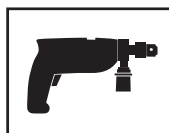

The machine information on the packaging and displays

Details on machine suitability can also be found on the machine icons on Osborn packaging and counter and shelf displays.

Brushes Power drill

BRUSHES



Wheel Brushes
knotted wire

SPECIAL

For heavy-duty cleaning and deburring applications such as slag and silicate removal, weld seam finishing or removal of the underfloor protection in motor vehicles.

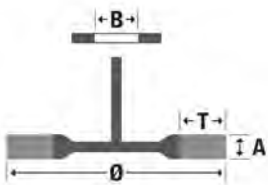

USAGE

	0,25	0,35	0,50	0,60	0,80
roughening	<input type="checkbox"/>	<input type="checkbox"/>	<input checked="" type="checkbox"/>	<input checked="" type="checkbox"/>	<input checked="" type="checkbox"/>
planing	<input type="checkbox"/>	<input type="checkbox"/>	<input type="checkbox"/>	<input type="checkbox"/>	<input type="checkbox"/>
deburring	<input checked="" type="checkbox"/>	<input checked="" type="checkbox"/>	<input type="checkbox"/>	<input type="checkbox"/>	<input type="checkbox"/>
edge honing	<input checked="" type="checkbox"/>	<input type="checkbox"/>	<input type="checkbox"/>	<input type="checkbox"/>	<input type="checkbox"/>
structuring	<input type="checkbox"/>	<input type="checkbox"/>	<input type="checkbox"/>	<input type="checkbox"/>	<input type="checkbox"/>
descaling/paint stripping	<input checked="" type="checkbox"/>	<input checked="" type="checkbox"/>	<input checked="" type="checkbox"/>	<input checked="" type="checkbox"/>	<input checked="" type="checkbox"/>
weld seams	<input checked="" type="checkbox"/>	<input checked="" type="checkbox"/>	<input checked="" type="checkbox"/>	<input checked="" type="checkbox"/>	<input checked="" type="checkbox"/>

TRIM AND MATERIAL

Products available with:

Steel wire twist knot	<input checked="" type="checkbox"/>	<input checked="" type="checkbox"/>	<input type="checkbox"/>	<input type="checkbox"/>	<input type="checkbox"/>	<input type="checkbox"/>	<input type="checkbox"/>
Stainless steel	<input type="checkbox"/>	<input type="checkbox"/>	<input checked="" type="checkbox"/>	<input checked="" type="checkbox"/>	<input checked="" type="checkbox"/>	<input type="checkbox"/>	<input type="checkbox"/>

mm						0,35	RRP	0,50	RRP	0,50	RRP
Ø	A	T	S	rpm	pcs.	Order-No.	€	Order-No.	€	Order-No.	€
75	12	18	6	20000	12	0202-611 131		0202-611 151		0202-611 351	

Wheel Brushes
knotted wire

SPECIAL

Do-it-yourself type for commercially available power drills in self-service packaging.

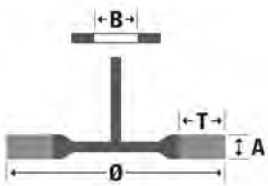

USAGE

	0,25	0,35	0,50	0,60	0,80
roughening	<input type="checkbox"/>	<input type="checkbox"/>	<input checked="" type="checkbox"/>	<input checked="" type="checkbox"/>	<input checked="" type="checkbox"/>
planing	<input checked="" type="checkbox"/>	<input checked="" type="checkbox"/>	<input type="checkbox"/>	<input type="checkbox"/>	<input type="checkbox"/>
deburring	<input checked="" type="checkbox"/>	<input checked="" type="checkbox"/>	<input type="checkbox"/>	<input type="checkbox"/>	<input type="checkbox"/>
edge honing	<input checked="" type="checkbox"/>	<input type="checkbox"/>	<input type="checkbox"/>	<input type="checkbox"/>	<input type="checkbox"/>
structuring	<input type="checkbox"/>	<input type="checkbox"/>	<input type="checkbox"/>	<input type="checkbox"/>	<input type="checkbox"/>
descaling/paint stripping	<input checked="" type="checkbox"/>	<input checked="" type="checkbox"/>	<input checked="" type="checkbox"/>	<input checked="" type="checkbox"/>	<input checked="" type="checkbox"/>
weld seams	<input checked="" type="checkbox"/>	<input checked="" type="checkbox"/>	<input checked="" type="checkbox"/>	<input checked="" type="checkbox"/>	<input checked="" type="checkbox"/>

TRIM AND MATERIAL

Products available with:

Steel wire twist knot	<input checked="" type="checkbox"/>	<input checked="" type="checkbox"/>	<input type="checkbox"/>	<input type="checkbox"/>	<input type="checkbox"/>	<input type="checkbox"/>	<input type="checkbox"/>
Stainless steel	<input type="checkbox"/>	<input type="checkbox"/>	<input checked="" type="checkbox"/>	<input checked="" type="checkbox"/>	<input checked="" type="checkbox"/>	<input type="checkbox"/>	<input type="checkbox"/>

mm						0,50	UVP	0,50	UVP
Ø	A	T	S	rpm	pcs.	Order-No.	€	Order-No.	€
75	12	18	6	20000	8	7202-611 151		7012-611 351	

Brushes

Power drill

Wheel Brushes

crimped wire



SPECIAL



Recommended working speed approx. 50% of maximum RPM. For non-destructive and light cleaning work, deburring and processing bores.

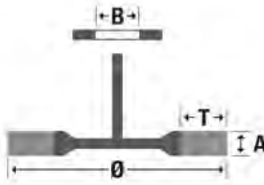

USAGE

	0,15	0,20	0,25/0,27	0,30	0,35	0,40	0,50
roughening	<input type="checkbox"/>	<input type="checkbox"/>	<input type="checkbox"/>	<input type="checkbox"/>	<input type="checkbox"/>	<input type="checkbox"/>	<input type="checkbox"/>
planing	<input type="checkbox"/>	<input type="checkbox"/>	<input type="checkbox"/>	<input type="checkbox"/>	<input type="checkbox"/>	<input type="checkbox"/>	<input type="checkbox"/>
deburring	<input type="checkbox"/>	<input type="checkbox"/>	<input type="checkbox"/>	<input type="checkbox"/>	<input type="checkbox"/>	<input type="checkbox"/>	<input type="checkbox"/>
edge honing	<input type="checkbox"/>	<input type="checkbox"/>	<input type="checkbox"/>	<input type="checkbox"/>	<input type="checkbox"/>	<input type="checkbox"/>	<input type="checkbox"/>
structuring	<input type="checkbox"/>	<input type="checkbox"/>	<input type="checkbox"/>	<input type="checkbox"/>	<input type="checkbox"/>	<input type="checkbox"/>	<input type="checkbox"/>
descaling/paint stripping	<input type="checkbox"/>	<input type="checkbox"/>	<input type="checkbox"/>	<input type="checkbox"/>	<input type="checkbox"/>	<input type="checkbox"/>	<input type="checkbox"/>
weld seams	<input type="checkbox"/>	<input type="checkbox"/>	<input type="checkbox"/>	<input type="checkbox"/>	<input type="checkbox"/>	<input type="checkbox"/>	<input type="checkbox"/>

TRIM AND MATERIAL

Products available with:

Steel wire crimped

Stainless steel

Brass wire

	Steel	Cast steel	Stainless steel	Non-ferrous metal	Aluminium	Soft wood	Hard wood
Steel wire crimped	<input checked="" type="checkbox"/>	<input checked="" type="checkbox"/>	<input checked="" type="checkbox"/>	<input checked="" type="checkbox"/>	<input checked="" type="checkbox"/>	<input checked="" type="checkbox"/>	<input checked="" type="checkbox"/>
Stainless steel	<input type="checkbox"/>	<input type="checkbox"/>	<input checked="" type="checkbox"/>	<input checked="" type="checkbox"/>	<input checked="" type="checkbox"/>	<input checked="" type="checkbox"/>	<input checked="" type="checkbox"/>
Brass wire	<input type="checkbox"/>	<input type="checkbox"/>	<input type="checkbox"/>	<input checked="" type="checkbox"/>	<input checked="" type="checkbox"/>	<input checked="" type="checkbox"/>	<input checked="" type="checkbox"/>

mm				0,15	RRP	0,20	RRP	0,30	RRP
Ø	A	T	rpm	Order-No.	€	Order-No.	€	Order-No.	€
20	6	4	20000	10	0002-501 132			0002-501 142	
20	9	4	20000	10				0002-501 143	
30	6	6	20000	10				0002-502 141	
30	9	6	20000	10	0002-502 132			0002-502 142	
30	12	6	20000	10				0002-502 143	
40	11	10	18000	10	0002-503 132			0002-503 142	
40	16	10	18000	10				0002-503 143	
50	10	13	15000	10				0002-504 141	0002-504 161
50	17	13	15000	10	0002-504 132			0002-504 142	0002-504 162
50	23	13	15000	10				0002-504 143	0002-504 163
60	12	15	15000	10				0002-505 141	0002-505 161
60	18	15	15000	10	0002-505 132			0002-505 142	0002-505 162
70	11	15	15000	10				0002-506 141	0002-506 161
70	18	15	15000	10	0002-506 132			0002-506 142	
80	19	20	15000	10				0002-507 142	0002-507 162

mm				0,15	RRP	0,20	RRP	0,30	RRP
Ø	A	T	rpm	Order-No.	€	Order-No.	€	Order-No.	€
30	6	6	20000	10		0002-502 341			
30	9	6	20000	10	0002-502 332				
30	12	6	20000	10	0002-502 333				
40	7	10	18000	10	0002-503 331				
40	11	10	18000	10	0002-503 332				
40	16	10	18000	10	0002-503 333				
50	10	13	15000	10		0002-504 341		0002-504 361	
50	17	13	15000	10	0002-504 332			0002-504 342	0002-504 362
50	23	13	15000	10		0002-504 343		0002-504 363	
60	12	15	15000	10		0002-505 341		0002-505 361	
60	18	15	15000	10	0002-505 332			0002-505 342	0002-505 362
60	23	15	15000	10		0002-505 343		0002-505 363	
70	11	15	15000	10		0002-506 341		0002-506 361	
70	18	15	15000	10	0002-506 332			0002-506 342	0002-506 362
70	23	15	15000	10		0002-506 343		0002-506 363	
80	10	20	12000	10				5162-507 361	
80	19	20	12000	10		0002-507 342		0002-507 362	

mm				0,20	RRP				
Ø	A	T	rpm	Order-No.	€	Order-No.	€	Order-No.	€
30	9	6	20000	10	0002-502 542				
40	11	10	18000	10	0002-503 542				
50	17	13	15000	10	0002-504 542				
60	18	15	15000	10	0002-505 542				
70	18	15	15000	10	0002-506 542				
80	19	20	12000	10	0002-507 542				

Brushes Power drill

BRUSHES

Wheel Brushes crimped wire



High performance brushes for powerdrills and straight grinders in self-service packaging.

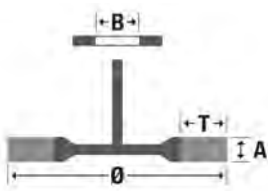

USAGE

		0,15	0,20	0,25/0,27					
roughening	<input type="checkbox"/>	<input type="checkbox"/>	<input type="checkbox"/>	<input type="checkbox"/>	<input type="checkbox"/>	<input type="checkbox"/>	<input type="checkbox"/>	<input type="checkbox"/>	<input type="checkbox"/>
planing	<input type="checkbox"/>	<input type="checkbox"/>	<input type="checkbox"/>	<input type="checkbox"/>	<input type="checkbox"/>	<input type="checkbox"/>	<input type="checkbox"/>	<input type="checkbox"/>	<input type="checkbox"/>
deburring	<input type="checkbox"/>	<input type="checkbox"/>	<input type="checkbox"/>	<input type="checkbox"/>	<input type="checkbox"/>	<input type="checkbox"/>	<input type="checkbox"/>	<input type="checkbox"/>	<input type="checkbox"/>
edge honing	<input type="checkbox"/>	<input type="checkbox"/>	<input type="checkbox"/>	<input type="checkbox"/>	<input type="checkbox"/>	<input type="checkbox"/>	<input type="checkbox"/>	<input type="checkbox"/>	<input type="checkbox"/>
structuring	<input type="checkbox"/>	<input type="checkbox"/>	<input type="checkbox"/>	<input type="checkbox"/>	<input type="checkbox"/>	<input type="checkbox"/>	<input type="checkbox"/>	<input type="checkbox"/>	<input type="checkbox"/>
descaling/paint stripping	<input type="checkbox"/>	<input type="checkbox"/>	<input type="checkbox"/>	<input type="checkbox"/>	<input type="checkbox"/>	<input type="checkbox"/>	<input type="checkbox"/>	<input type="checkbox"/>	<input type="checkbox"/>
weld seams	<input type="checkbox"/>	<input type="checkbox"/>	<input type="checkbox"/>	<input type="checkbox"/>	<input type="checkbox"/>	<input type="checkbox"/>	<input type="checkbox"/>	<input type="checkbox"/>	<input type="checkbox"/>

TRIM AND MATERIAL

Products available with:

Steel wire crimped		Steel	Cast steel	Stainless steel	Non-ferrous metal	Aluminium	Soft wood	Hard wood
Stainless steel								
Brass wire								

mm						0,20	RRP	0,30	RRP	0,20	RRP
Ø	A	T	S	rpm	pcs.	Order-No.	€	Order-No.	€	Order-No.	€
50	17	13	6	15000	6					3002-504 342	
60	18	15	6	15000	6			7002-505 162			
70	18	15	6	15000	6	7022-506 142					
80	19	20	6	12000	6	7002-507 142		7002-507 162		7002-507 342	

mm						0,30	RRP	0,20	RRP
Ø	A	T	S	rpm	pcs.	Order-No.	€	Order-No.	€
50	17	13	6	15000	6	7002-504 362			
60	18	15	6	15000	6			7002-505 542	
80	19	20	6	12000	6	7002-507 362			

Wheel Brushes crimped wire



Do-it-yourself type for commercially available power drills.

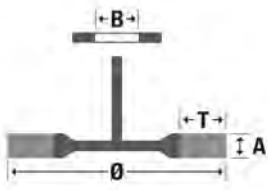

USAGE

		0,15	0,20	0,25/0,27					
roughening	<input type="checkbox"/>	<input type="checkbox"/>	<input type="checkbox"/>	<input type="checkbox"/>	<input type="checkbox"/>	<input type="checkbox"/>	<input type="checkbox"/>	<input type="checkbox"/>	<input type="checkbox"/>
planing	<input type="checkbox"/>	<input type="checkbox"/>	<input type="checkbox"/>	<input type="checkbox"/>	<input type="checkbox"/>	<input type="checkbox"/>	<input type="checkbox"/>	<input type="checkbox"/>	<input type="checkbox"/>
deburring	<input type="checkbox"/>	<input type="checkbox"/>	<input type="checkbox"/>	<input type="checkbox"/>	<input type="checkbox"/>	<input type="checkbox"/>	<input type="checkbox"/>	<input type="checkbox"/>	<input type="checkbox"/>
edge honing	<input type="checkbox"/>	<input type="checkbox"/>	<input type="checkbox"/>	<input type="checkbox"/>	<input type="checkbox"/>	<input type="checkbox"/>	<input type="checkbox"/>	<input type="checkbox"/>	<input type="checkbox"/>
structuring	<input type="checkbox"/>	<input type="checkbox"/>	<input type="checkbox"/>	<input type="checkbox"/>	<input type="checkbox"/>	<input type="checkbox"/>	<input type="checkbox"/>	<input type="checkbox"/>	<input type="checkbox"/>
descaling/paint stripping	<input type="checkbox"/>	<input type="checkbox"/>	<input type="checkbox"/>	<input type="checkbox"/>	<input type="checkbox"/>	<input type="checkbox"/>	<input type="checkbox"/>	<input type="checkbox"/>	<input type="checkbox"/>
weld seams	<input type="checkbox"/>	<input type="checkbox"/>	<input type="checkbox"/>	<input type="checkbox"/>	<input type="checkbox"/>	<input type="checkbox"/>	<input type="checkbox"/>	<input type="checkbox"/>	<input type="checkbox"/>

TRIM AND MATERIAL

Products available with:

Steel wire crimped		Steel	Cast steel	Stainless steel	Non-ferrous metal	Aluminium	Soft wood	Hard wood
Stainless steel								

mm						0,20	RRP	0,30	RRP
Ø	A	T	S	rpm	pcs.	Order-No.	€	Order-No.	€
50	7	10		4500	20	0003-600 211		0008-600 221	
63	9	13		4500	20	0003-600 311		0008-600 321	
75	10	16		4500	10	0008-600 411		0008-600 421	
75	15	16		4500	10			0008-600 422	
100	12	22		4500	10	0008-600 511		0008-600 521	
100	17	22		4500	10			0008-600 522	

mm						0,20	RRP	0,30	RRP
Ø	A	T	S	rpm	pcs.	Order-No.	€	Order-No.	€
50	7	10		4500	20	0088-600 221			
75	10	16		4500	10			0008-600 432	
100	10	22		4500	10	0008-600 531		0088-600 521	

Brushes

Power drill

Wheel Brushes
crimped wire



PERFECT

Do-it-yourself type for commercially available power drills in self-service packaging.

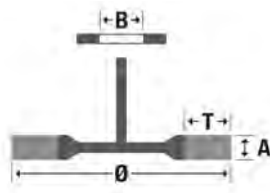

USAGE

	0,15	0,20	0,25/0,27	0,30	0,35	0,40	0,50
roughening	<input type="checkbox"/>	<input type="checkbox"/>	<input type="checkbox"/>	<input type="checkbox"/>	<input type="checkbox"/>	<input type="checkbox"/>	<input type="checkbox"/>
planing	<input type="checkbox"/>	<input type="checkbox"/>	<input type="checkbox"/>	<input type="checkbox"/>	<input type="checkbox"/>	<input type="checkbox"/>	<input type="checkbox"/>
deburring	<input type="checkbox"/>	<input type="checkbox"/>	<input type="checkbox"/>	<input type="checkbox"/>	<input type="checkbox"/>	<input type="checkbox"/>	<input type="checkbox"/>
edge honing	<input type="checkbox"/>	<input type="checkbox"/>	<input type="checkbox"/>	<input type="checkbox"/>	<input type="checkbox"/>	<input type="checkbox"/>	<input type="checkbox"/>
structuring	<input type="checkbox"/>	<input type="checkbox"/>	<input type="checkbox"/>	<input type="checkbox"/>	<input type="checkbox"/>	<input type="checkbox"/>	<input type="checkbox"/>
descaling/paint stripping	<input type="checkbox"/>	<input type="checkbox"/>	<input type="checkbox"/>	<input type="checkbox"/>	<input type="checkbox"/>	<input type="checkbox"/>	<input type="checkbox"/>
weld seams	<input type="checkbox"/>	<input type="checkbox"/>	<input type="checkbox"/>	<input type="checkbox"/>	<input type="checkbox"/>	<input type="checkbox"/>	<input type="checkbox"/>

TRIM AND MATERIAL

Products available with:

Steel wire crimped → Steel Cast steel Stainless steel Non-ferrous metal Aluminium Soft wood Hard wood

Stainless steel → Steel Cast steel Stainless steel Non-ferrous metal Aluminium Soft wood Hard wood

mm						0,30	RRP	0,30	UVP
Ø	A	T	S	rpm	pcs.	Order-No.	€	Order-No.	€
50	7	10	6	4500	8			7003-600 221	
75	10	16	6	4500	8			7003-600 421	
100	12	22	6	4500	8			7003-600 521	
100	12	22	6	4500	6	7018-600 521			

Wheel Brushes
crimped wire



SPECIAL

Wheel brushes for wood working. Particularly suitable for brushing out annual (year) rings. Supplied on 8 mm shaft.

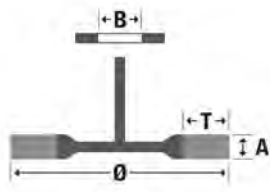

USAGE

	0,15	0,20	0,25/0,27	0,30	0,35	0,40	0,50
roughening	<input type="checkbox"/>	<input type="checkbox"/>	<input type="checkbox"/>	<input type="checkbox"/>	<input type="checkbox"/>	<input type="checkbox"/>	<input type="checkbox"/>
planing	<input type="checkbox"/>	<input type="checkbox"/>	<input type="checkbox"/>	<input type="checkbox"/>	<input type="checkbox"/>	<input type="checkbox"/>	<input type="checkbox"/>
deburring	<input type="checkbox"/>	<input type="checkbox"/>	<input type="checkbox"/>	<input type="checkbox"/>	<input type="checkbox"/>	<input type="checkbox"/>	<input type="checkbox"/>
edge honing	<input type="checkbox"/>	<input type="checkbox"/>	<input type="checkbox"/>	<input type="checkbox"/>	<input type="checkbox"/>	<input type="checkbox"/>	<input type="checkbox"/>
structuring	<input type="checkbox"/>	<input type="checkbox"/>	<input type="checkbox"/>	<input type="checkbox"/>	<input type="checkbox"/>	<input type="checkbox"/>	<input type="checkbox"/>
descaling/paint stripping	<input type="checkbox"/>	<input type="checkbox"/>	<input type="checkbox"/>	<input type="checkbox"/>	<input type="checkbox"/>	<input type="checkbox"/>	<input type="checkbox"/>
weld seams	<input type="checkbox"/>	<input type="checkbox"/>	<input type="checkbox"/>	<input type="checkbox"/>	<input type="checkbox"/>	<input type="checkbox"/>	<input type="checkbox"/>

TRIM AND MATERIAL

Products available with:

Steel wire crimped → Steel Cast steel Stainless steel Non-ferrous metal Aluminium Soft wood Hard wood

mm						0,25 cordwire	RRP		
Ø	A	T	rpm	pcs.	Order-No.	€	Order-No.	€	Order-No.
80	35	25	4000	10	0908-507 061				

Brushes Power drill

BRUSHES



Wheel Brushes
crimped wire

SPECIAL

Do-it-yourself type for commercially available power drills in self-service packaging.

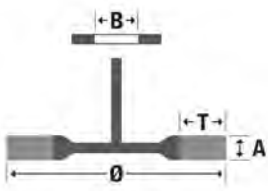

USAGE

	0,15	0,20	0,25/0,27	0,30	0,35	0,40	0,50
roughening	<input type="checkbox"/>	<input type="checkbox"/>	<input type="checkbox"/>	<input type="checkbox"/>	<input type="checkbox"/>	<input type="checkbox"/>	<input type="checkbox"/>
planing	<input checked="" type="checkbox"/>	<input checked="" type="checkbox"/>	<input checked="" type="checkbox"/>	<input checked="" type="checkbox"/>	<input checked="" type="checkbox"/>	<input checked="" type="checkbox"/>	<input checked="" type="checkbox"/>
deburring	<input checked="" type="checkbox"/>	<input checked="" type="checkbox"/>	<input checked="" type="checkbox"/>	<input checked="" type="checkbox"/>	<input checked="" type="checkbox"/>	<input checked="" type="checkbox"/>	<input checked="" type="checkbox"/>
edge honing	<input checked="" type="checkbox"/>	<input checked="" type="checkbox"/>	<input checked="" type="checkbox"/>	<input checked="" type="checkbox"/>	<input checked="" type="checkbox"/>	<input checked="" type="checkbox"/>	<input checked="" type="checkbox"/>
structuring	<input type="checkbox"/>	<input checked="" type="checkbox"/>	<input checked="" type="checkbox"/>	<input checked="" type="checkbox"/>	<input checked="" type="checkbox"/>	<input checked="" type="checkbox"/>	<input checked="" type="checkbox"/>
descaling/paint stripping	<input type="checkbox"/>	<input type="checkbox"/>	<input type="checkbox"/>	<input type="checkbox"/>	<input type="checkbox"/>	<input type="checkbox"/>	<input type="checkbox"/>
weld seams	<input checked="" type="checkbox"/>	<input checked="" type="checkbox"/>	<input checked="" type="checkbox"/>	<input checked="" type="checkbox"/>	<input checked="" type="checkbox"/>	<input checked="" type="checkbox"/>	<input checked="" type="checkbox"/>

TRIM AND MATERIAL

Products available with:

Steel wire crimped → Steel Cast steel Stainless steel Non-ferrous metal Aluminium Soft wood Hard wood

mm					0,25 cordwire	RRP				
Ø	A	T	rpm	pcs.	Order-No.	€	Order-No.	€	Order-No.	€
80	35	25	4000	10	7003-507 061					

Wheel Brushes
crimped wire plastic-bonded

EVOLUTION

Brush with plastic-bonded wire for longer service life and reduced wire breakage.

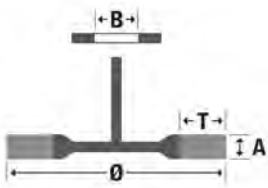

USAGE

	0,15	0,20	0,25/0,27	0,30	0,35	0,40	0,50
roughening	<input type="checkbox"/>	<input type="checkbox"/>	<input type="checkbox"/>	<input type="checkbox"/>	<input type="checkbox"/>	<input type="checkbox"/>	<input type="checkbox"/>
planing	<input checked="" type="checkbox"/>	<input checked="" type="checkbox"/>	<input checked="" type="checkbox"/>	<input checked="" type="checkbox"/>	<input checked="" type="checkbox"/>	<input checked="" type="checkbox"/>	<input checked="" type="checkbox"/>
deburring	<input checked="" type="checkbox"/>	<input checked="" type="checkbox"/>	<input checked="" type="checkbox"/>	<input checked="" type="checkbox"/>	<input checked="" type="checkbox"/>	<input checked="" type="checkbox"/>	<input checked="" type="checkbox"/>
edge honing	<input checked="" type="checkbox"/>	<input checked="" type="checkbox"/>	<input checked="" type="checkbox"/>	<input checked="" type="checkbox"/>	<input checked="" type="checkbox"/>	<input checked="" type="checkbox"/>	<input checked="" type="checkbox"/>
structuring	<input type="checkbox"/>	<input checked="" type="checkbox"/>	<input checked="" type="checkbox"/>	<input checked="" type="checkbox"/>	<input checked="" type="checkbox"/>	<input checked="" type="checkbox"/>	<input checked="" type="checkbox"/>
descaling/paint stripping	<input type="checkbox"/>	<input type="checkbox"/>	<input type="checkbox"/>	<input type="checkbox"/>	<input type="checkbox"/>	<input type="checkbox"/>	<input type="checkbox"/>
weld seams	<input checked="" type="checkbox"/>	<input checked="" type="checkbox"/>	<input checked="" type="checkbox"/>	<input checked="" type="checkbox"/>	<input checked="" type="checkbox"/>	<input checked="" type="checkbox"/>	<input checked="" type="checkbox"/>

TRIM AND MATERIAL

Products available with:

Steel wire crimped → Steel Cast steel Stainless steel Non-ferrous metal Aluminium Soft wood Hard wood

mm					0,30	RRP				
Ø	A	T	rpm	pcs.	Order-No.	€	Order-No.	€	Order-No.	€
63	8	20	15000	12	0002-911 941					
76	8	26	15000	12	0002-911 951					

Brushes

Power drill

Wheel Brushes
abrasive filament



PERFECT 

The trim on these brushes follows the contours of the work piece without significantly affecting the surface. Brushes with abrasive bristles for cleaning materials.

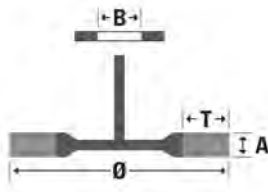

USAGE



	40/46	60	80	120	180	320	Fibre
roughening	<input checked="" type="checkbox"/>	<input checked="" type="checkbox"/>	<input checked="" type="checkbox"/>	<input checked="" type="checkbox"/>	<input checked="" type="checkbox"/>	<input checked="" type="checkbox"/>	<input checked="" type="checkbox"/>
planing	<input type="checkbox"/>	<input type="checkbox"/>	<input type="checkbox"/>	<input type="checkbox"/>	<input type="checkbox"/>	<input type="checkbox"/>	<input type="checkbox"/>
deburring	<input type="checkbox"/>	<input type="checkbox"/>	<input type="checkbox"/>	<input type="checkbox"/>	<input type="checkbox"/>	<input type="checkbox"/>	<input type="checkbox"/>
edge honing	<input type="checkbox"/>	<input type="checkbox"/>	<input type="checkbox"/>	<input type="checkbox"/>	<input type="checkbox"/>	<input type="checkbox"/>	<input type="checkbox"/>
structuring	<input type="checkbox"/>	<input type="checkbox"/>	<input type="checkbox"/>	<input type="checkbox"/>	<input type="checkbox"/>	<input type="checkbox"/>	<input type="checkbox"/>
descaling/paint stripping	<input type="checkbox"/>	<input type="checkbox"/>	<input type="checkbox"/>	<input type="checkbox"/>	<input type="checkbox"/>	<input type="checkbox"/>	<input type="checkbox"/>
weld seams	<input type="checkbox"/>	<input type="checkbox"/>	<input type="checkbox"/>	<input type="checkbox"/>	<input type="checkbox"/>	<input type="checkbox"/>	<input type="checkbox"/>

TRIM AND MATERIAL

Products available with:

Abrasive bristle → Steel Cast steel Stainless steel Non-ferrous metal Aluminium Soft wood Hard wood

mm					grit 80 red	RRP	grit 180 blue	RRP		
Ø	A	T	rpm	pcs.	Order-No.	€	Order-No.	€	Order-No.	€
75	10	16	4500	10	0802-600 491		0182-600 491			
100	10	23	4500	10	0802-600 591		0182-600 591			

Wheel Brushes
abrasive filament



PERFECT 

Do-it-yourself type for commercially available power drills in self-service packaging.

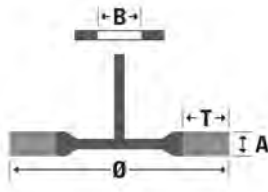

USAGE



	40/46	60	80	120	180	320	Fibre
roughening	<input checked="" type="checkbox"/>	<input checked="" type="checkbox"/>	<input checked="" type="checkbox"/>	<input checked="" type="checkbox"/>	<input checked="" type="checkbox"/>	<input checked="" type="checkbox"/>	<input checked="" type="checkbox"/>
planing	<input type="checkbox"/>	<input type="checkbox"/>	<input type="checkbox"/>	<input type="checkbox"/>	<input type="checkbox"/>	<input type="checkbox"/>	<input type="checkbox"/>
deburring	<input type="checkbox"/>	<input type="checkbox"/>	<input type="checkbox"/>	<input type="checkbox"/>	<input type="checkbox"/>	<input type="checkbox"/>	<input type="checkbox"/>
edge honing	<input type="checkbox"/>	<input type="checkbox"/>	<input type="checkbox"/>	<input type="checkbox"/>	<input type="checkbox"/>	<input type="checkbox"/>	<input type="checkbox"/>
structuring	<input type="checkbox"/>	<input type="checkbox"/>	<input type="checkbox"/>	<input type="checkbox"/>	<input type="checkbox"/>	<input type="checkbox"/>	<input type="checkbox"/>
descaling/paint stripping	<input type="checkbox"/>	<input type="checkbox"/>	<input type="checkbox"/>	<input type="checkbox"/>	<input type="checkbox"/>	<input type="checkbox"/>	<input type="checkbox"/>
weld seams	<input type="checkbox"/>	<input type="checkbox"/>	<input type="checkbox"/>	<input type="checkbox"/>	<input type="checkbox"/>	<input type="checkbox"/>	<input type="checkbox"/>

TRIM AND MATERIAL

Products available with:

Abrasive bristle → Steel Cast steel Stainless steel Non-ferrous metal Aluminium Soft wood Hard wood

mm					grit 80 red	RRP	grit 180 blue	RRP		
Ø	A	T	rpm	pcs.	Order-No.	€	Order-No.	€	Order-No.	€
75	10	16	4500	10	7802-600 491		7182-600 491			
100	10	23	4500	10	7802-600 591		7182-600 591			

Brushes Power drill

BRUSHES



Cup Brushes
knotted wire

SPECIAL

High performance cup brushes for demanding cleaning work.

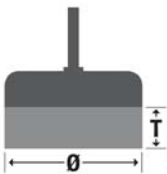

USAGE

	0,25	0,35	0,50	0,60	0,80
roughening	<input type="checkbox"/>	<input type="checkbox"/>	<input checked="" type="checkbox"/>	<input checked="" type="checkbox"/>	<input checked="" type="checkbox"/>
planing	<input type="checkbox"/>	<input type="checkbox"/>	<input type="checkbox"/>	<input type="checkbox"/>	<input type="checkbox"/>
deburring	<input checked="" type="checkbox"/>	<input checked="" type="checkbox"/>	<input type="checkbox"/>	<input type="checkbox"/>	<input type="checkbox"/>
edge honing	<input checked="" type="checkbox"/>	<input type="checkbox"/>	<input type="checkbox"/>	<input type="checkbox"/>	<input type="checkbox"/>
structuring	<input type="checkbox"/>	<input type="checkbox"/>	<input type="checkbox"/>	<input type="checkbox"/>	<input type="checkbox"/>
descaling/paint stripping	<input checked="" type="checkbox"/>	<input checked="" type="checkbox"/>	<input checked="" type="checkbox"/>	<input checked="" type="checkbox"/>	<input checked="" type="checkbox"/>
weld seams	<input checked="" type="checkbox"/>	<input checked="" type="checkbox"/>	<input checked="" type="checkbox"/>	<input checked="" type="checkbox"/>	<input checked="" type="checkbox"/>

TRIM AND MATERIAL

Products available with:

Steel wire twist knot → Steel Cast steel Stainless steel Non-ferrous metal Aluminium Soft wood Hard wood

mm				0,50	RRP				
Ø	T	rpm	pcs.	Order-No.	€	Order-No.	€	Order-No.	€
65	23	6000	10	1004-608 151					

Cup Brushes
knotted wire

SPECIAL

Do-it-yourself type for commercially available power drills in self-service packaging.

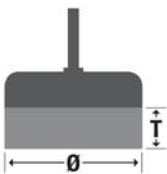

USAGE

	0,25	0,35	0,50	0,60	0,80
roughening	<input type="checkbox"/>	<input type="checkbox"/>	<input checked="" type="checkbox"/>	<input checked="" type="checkbox"/>	<input checked="" type="checkbox"/>
planing	<input checked="" type="checkbox"/>	<input type="checkbox"/>	<input type="checkbox"/>	<input type="checkbox"/>	<input type="checkbox"/>
deburring	<input checked="" type="checkbox"/>	<input type="checkbox"/>	<input type="checkbox"/>	<input type="checkbox"/>	<input type="checkbox"/>
edge honing	<input checked="" type="checkbox"/>	<input type="checkbox"/>	<input type="checkbox"/>	<input type="checkbox"/>	<input type="checkbox"/>
structuring	<input type="checkbox"/>	<input type="checkbox"/>	<input type="checkbox"/>	<input type="checkbox"/>	<input type="checkbox"/>
descaling/paint stripping	<input checked="" type="checkbox"/>	<input checked="" type="checkbox"/>	<input checked="" type="checkbox"/>	<input checked="" type="checkbox"/>	<input checked="" type="checkbox"/>
weld seams	<input checked="" type="checkbox"/>	<input checked="" type="checkbox"/>	<input checked="" type="checkbox"/>	<input checked="" type="checkbox"/>	<input checked="" type="checkbox"/>

TRIM AND MATERIAL

Products available with:

Steel wire twist knot → Steel Cast steel Stainless steel Non-ferrous metal Aluminium Soft wood Hard wood

mm				0,50	RRP				
Ø	T	rpm	pcs.	Order-No.	€	Order-No.	€	Order-No.	€
65	23	6000	10	7004-608 151					

Brushes

Power drill

Cup Brushes
crimped wire



PERFECT

Do-it-yourself type for power drills.



USAGE

	0,15	0,20	0,25/0,27	0,30	0,35	0,40	0,50
roughening	<input type="checkbox"/>	<input type="checkbox"/>	<input type="checkbox"/>	<input type="checkbox"/>	<input type="checkbox"/>	<input type="checkbox"/>	<input type="checkbox"/>
planing	<input type="checkbox"/>	<input type="checkbox"/>	<input type="checkbox"/>	<input type="checkbox"/>	<input type="checkbox"/>	<input type="checkbox"/>	<input type="checkbox"/>
deburring	<input type="checkbox"/>	<input type="checkbox"/>	<input type="checkbox"/>	<input type="checkbox"/>	<input type="checkbox"/>	<input type="checkbox"/>	<input type="checkbox"/>
edge honing	<input type="checkbox"/>	<input type="checkbox"/>	<input type="checkbox"/>	<input type="checkbox"/>	<input type="checkbox"/>	<input type="checkbox"/>	<input type="checkbox"/>
structuring	<input type="checkbox"/>	<input type="checkbox"/>	<input type="checkbox"/>	<input type="checkbox"/>	<input type="checkbox"/>	<input type="checkbox"/>	<input type="checkbox"/>
descaling/paint stripping	<input type="checkbox"/>	<input type="checkbox"/>	<input type="checkbox"/>	<input type="checkbox"/>	<input type="checkbox"/>	<input type="checkbox"/>	<input type="checkbox"/>
weld seams	<input type="checkbox"/>	<input type="checkbox"/>	<input type="checkbox"/>	<input type="checkbox"/>	<input type="checkbox"/>	<input type="checkbox"/>	<input type="checkbox"/>

TRIM AND MATERIAL

Products available with:

Steel wire crimped	Steel	Cast steel	Stainless steel	Non-ferrous metal	Aluminium	Soft wood	Hard wood
Stainless steel	<input checked="" type="checkbox"/>	<input checked="" type="checkbox"/>	<input checked="" type="checkbox"/>	<input checked="" type="checkbox"/>	<input checked="" type="checkbox"/>	<input checked="" type="checkbox"/>	<input checked="" type="checkbox"/>
Brass wire	<input type="checkbox"/>	<input type="checkbox"/>	<input type="checkbox"/>	<input type="checkbox"/>	<input type="checkbox"/>	<input type="checkbox"/>	<input type="checkbox"/>

mm				0,20	RRP	0,30	RRP	0,20	RRP
Ø	T	rpm	pcs.	Order-No.	€	Order-No.	€	Order-No.	€
50	17	4500	20	0008-600 811		0008-600 821		0023-600 851	
75	20	4500	10	0008-600 911		0008-600 921		0023-600 951	

mm				0,30	RRP				
Ø	T	rpm	pcs.	Order-No.	€	Order-No.	€	Order-No.	€
50	17	4500	20	0008-600 832					
75	20	4500	10	0008-600 361					

Cup Brushes
crimped wire



PERFECT

Do-it-yourself type for power drills in self-service packaging.



USAGE

	0,15	0,20	0,25/0,27	0,30	0,35	0,40	0,50
roughening	<input type="checkbox"/>	<input type="checkbox"/>	<input type="checkbox"/>	<input type="checkbox"/>	<input type="checkbox"/>	<input type="checkbox"/>	<input type="checkbox"/>
planing	<input type="checkbox"/>	<input type="checkbox"/>	<input type="checkbox"/>	<input type="checkbox"/>	<input type="checkbox"/>	<input type="checkbox"/>	<input type="checkbox"/>
deburring	<input type="checkbox"/>	<input type="checkbox"/>	<input type="checkbox"/>	<input type="checkbox"/>	<input type="checkbox"/>	<input type="checkbox"/>	<input type="checkbox"/>
edge honing	<input type="checkbox"/>	<input type="checkbox"/>	<input type="checkbox"/>	<input type="checkbox"/>	<input type="checkbox"/>	<input type="checkbox"/>	<input type="checkbox"/>
structuring	<input type="checkbox"/>	<input type="checkbox"/>	<input type="checkbox"/>	<input type="checkbox"/>	<input type="checkbox"/>	<input type="checkbox"/>	<input type="checkbox"/>
descaling/paint stripping	<input type="checkbox"/>	<input type="checkbox"/>	<input type="checkbox"/>	<input type="checkbox"/>	<input type="checkbox"/>	<input type="checkbox"/>	<input type="checkbox"/>
weld seams	<input type="checkbox"/>	<input type="checkbox"/>	<input type="checkbox"/>	<input type="checkbox"/>	<input type="checkbox"/>	<input type="checkbox"/>	<input type="checkbox"/>

TRIM AND MATERIAL

Products available with:

Steel wire crimped	Steel	Cast steel	Stainless steel	Non-ferrous metal	Aluminium	Soft wood	Hard wood
Stainless steel	<input checked="" type="checkbox"/>	<input checked="" type="checkbox"/>	<input checked="" type="checkbox"/>	<input checked="" type="checkbox"/>	<input checked="" type="checkbox"/>	<input checked="" type="checkbox"/>	<input checked="" type="checkbox"/>

mm				0,30	RRP	0,30	UVP		
Ø	T	S	rpm	pcs.	Order-No.	€	Order-No.	€	Order-No.
50	17	6	4500	8			7003-600 821		
50	17	6	4500	6	7008-600 832				
75	20	6	4500	8			7003-600 921		
75	20	6	4500	6	7008-600 361				



Cup Brushes
crimped wire
plastic-bonded

EVOLUTION

Brush with plastic-bonded wire for longer service life and reduced wire breakage.

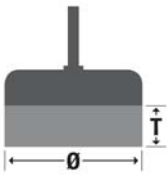

USAGE

	0,15	0,20	0,25/0,27	
roughening	<input type="checkbox"/>	<input type="checkbox"/>	<input type="checkbox"/>	<input type="checkbox"/>
planing	<input type="checkbox"/>	<input type="checkbox"/>	<input type="checkbox"/>	<input type="checkbox"/>
deburring	<input type="checkbox"/>	<input type="checkbox"/>	<input type="checkbox"/>	<input type="checkbox"/>
edge honing	<input type="checkbox"/>	<input type="checkbox"/>	<input type="checkbox"/>	<input type="checkbox"/>
structuring	<input type="checkbox"/>	<input type="checkbox"/>	<input type="checkbox"/>	<input type="checkbox"/>
descaling/paint stripping	<input type="checkbox"/>	<input type="checkbox"/>	<input type="checkbox"/>	<input type="checkbox"/>
weld seams	<input type="checkbox"/>	<input type="checkbox"/>	<input type="checkbox"/>	<input type="checkbox"/>

TRIM AND MATERIAL

Products available with:

Steel wire crimped → Steel Cast steel Stainless steel Non-ferrous metal Aluminium Soft wood Hard wood

mm				0,30	RRP				
Ø	T	rpm	pcs.	Order-No.	€	Order-No.	€	Order-No.	€
50	15	15000	12	0002-930 821					

Cup Brushes
abrasive filament

PERFECT

The trim on these brushes follows the contours of the work piece without significantly affecting the surface. Brushes with abrasive bristles for cleaning materials.



USAGE

	40/46	60	80	120	180	320	Fibre
roughening	<input checked="" type="checkbox"/>	<input type="checkbox"/>	<input type="checkbox"/>	<input type="checkbox"/>	<input type="checkbox"/>	<input type="checkbox"/>	<input type="checkbox"/>
planing	<input type="checkbox"/>	<input type="checkbox"/>	<input type="checkbox"/>	<input type="checkbox"/>	<input type="checkbox"/>	<input type="checkbox"/>	<input type="checkbox"/>
deburring	<input type="checkbox"/>	<input type="checkbox"/>	<input type="checkbox"/>	<input type="checkbox"/>	<input type="checkbox"/>	<input type="checkbox"/>	<input type="checkbox"/>
edge honing	<input type="checkbox"/>	<input type="checkbox"/>	<input type="checkbox"/>	<input type="checkbox"/>	<input type="checkbox"/>	<input type="checkbox"/>	<input type="checkbox"/>
structuring	<input type="checkbox"/>	<input type="checkbox"/>	<input type="checkbox"/>	<input type="checkbox"/>	<input type="checkbox"/>	<input type="checkbox"/>	<input type="checkbox"/>
descaling/paint stripping	<input type="checkbox"/>	<input type="checkbox"/>	<input type="checkbox"/>	<input type="checkbox"/>	<input type="checkbox"/>	<input type="checkbox"/>	<input type="checkbox"/>
weld seams	<input type="checkbox"/>	<input type="checkbox"/>	<input type="checkbox"/>	<input type="checkbox"/>	<input type="checkbox"/>	<input type="checkbox"/>	<input checked="" type="checkbox"/>

TRIM AND MATERIAL

Products available with:

Abrasive bristle → Steel Cast steel Stainless steel Non-ferrous metal Aluminium Soft wood Hard wood

mm				grit 80 red	RRP	grit 180 blue	RRP		
Ø	T	rpm	pcs.	Order-No.	€	Order-No.	€	Order-No.	€
50	17	4500	10	0802-600 891		0182-600 891			
75	23	4500	10	0802-600 991		0182-600 991			

Brushes

Power drill

Cup Brushes
abrasive filament



PERFECT



Do-it-yourself type for power drills in self-service packaging.



USAGE

	40/46	80	120	180	320	Fibre
roughening	<input checked="" type="checkbox"/>	<input checked="" type="checkbox"/>	<input checked="" type="checkbox"/>	<input checked="" type="checkbox"/>	<input checked="" type="checkbox"/>	<input checked="" type="checkbox"/>
planing	<input type="checkbox"/>	<input type="checkbox"/>	<input type="checkbox"/>	<input type="checkbox"/>	<input type="checkbox"/>	<input type="checkbox"/>
deburring	<input type="checkbox"/>	<input type="checkbox"/>	<input type="checkbox"/>	<input type="checkbox"/>	<input type="checkbox"/>	<input type="checkbox"/>
edge honing	<input type="checkbox"/>	<input type="checkbox"/>	<input type="checkbox"/>	<input type="checkbox"/>	<input type="checkbox"/>	<input type="checkbox"/>
structuring	<input type="checkbox"/>	<input type="checkbox"/>	<input type="checkbox"/>	<input type="checkbox"/>	<input type="checkbox"/>	<input type="checkbox"/>
descaling/paint stripping	<input type="checkbox"/>	<input type="checkbox"/>	<input type="checkbox"/>	<input type="checkbox"/>	<input type="checkbox"/>	<input type="checkbox"/>
weld seams	<input type="checkbox"/>	<input type="checkbox"/>	<input type="checkbox"/>	<input type="checkbox"/>	<input type="checkbox"/>	<input type="checkbox"/>

TRIM AND MATERIAL

Products available with:

Abrasive bristle →

Steel	Cast steel	Stainless steel	Non-ferrous metal	Aluminium	Soft wood	Hard wood
<input checked="" type="checkbox"/>	<input checked="" type="checkbox"/>	<input checked="" type="checkbox"/>	<input checked="" type="checkbox"/>	<input checked="" type="checkbox"/>	<input checked="" type="checkbox"/>	<input checked="" type="checkbox"/>

mm		max		grit 80 red	RRP	grit 180 blue	RRP		
Ø	T	rpm	pcs.	Order-No.	€	Order-No.	€	Order-No.	€
50	17	4500	10	7802-600 891		7182-600 891			
75	23	4500	10	7802-600 991		7182-600 991			

End Brushes
crimped wire



SPECIAL

End brushes for pin-point accuracy and hard-to-reach areas. Professional version.

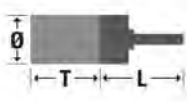

USAGE

	0,15	0,20	0,25/0,27	0,30	0,35	0,40	0,50
roughening	<input type="checkbox"/>	<input type="checkbox"/>	<input type="checkbox"/>	<input type="checkbox"/>	<input type="checkbox"/>	<input type="checkbox"/>	<input type="checkbox"/>
planing	<input type="checkbox"/>	<input type="checkbox"/>	<input type="checkbox"/>	<input type="checkbox"/>	<input type="checkbox"/>	<input type="checkbox"/>	<input type="checkbox"/>
deburring	<input type="checkbox"/>	<input type="checkbox"/>	<input type="checkbox"/>	<input type="checkbox"/>	<input type="checkbox"/>	<input type="checkbox"/>	<input type="checkbox"/>
edge honing	<input type="checkbox"/>	<input type="checkbox"/>	<input type="checkbox"/>	<input type="checkbox"/>	<input type="checkbox"/>	<input type="checkbox"/>	<input type="checkbox"/>
structuring	<input type="checkbox"/>	<input type="checkbox"/>	<input type="checkbox"/>	<input type="checkbox"/>	<input type="checkbox"/>	<input type="checkbox"/>	<input type="checkbox"/>
descaling/paint stripping	<input type="checkbox"/>	<input type="checkbox"/>	<input type="checkbox"/>	<input type="checkbox"/>	<input type="checkbox"/>	<input type="checkbox"/>	<input type="checkbox"/>
weld seams	<input type="checkbox"/>	<input type="checkbox"/>	<input type="checkbox"/>	<input type="checkbox"/>	<input type="checkbox"/>	<input type="checkbox"/>	<input type="checkbox"/>

TRIM AND MATERIAL

Products available with:

Steel wire crimped →

Stainless steel →

Brass wire →

Steel	Cast steel	Stainless steel	Non-ferrous metal	Aluminium	Soft wood	Hard wood
<input checked="" type="checkbox"/>	<input checked="" type="checkbox"/>	<input checked="" type="checkbox"/>	<input checked="" type="checkbox"/>	<input checked="" type="checkbox"/>	<input checked="" type="checkbox"/>	<input checked="" type="checkbox"/>

mm		max		0,20	RRP	0,30	RRP	0,50	RRP
Ø	T	L	rpm	Order-No.	€	Order-No.	€	Order-No.	€
10	20	40	20000	0003-509 141		0003-509 161		0003-509 191	
17	25	45	18000	0002-509 142		0002-509 162		0002-509 192	
25	25	50	18000	0002-509 143		0002-509 163		0002-509 193	
30	25	45	15000	0002-509 144		0002-509 164		0002-509 194	

mm		max		0,20	RRP	0,30	RRP	0,30	RRP
Ø	T	L	rpm	Order-No.	€	Order-No.	€	Order-No.	€
10	20	40	20000	0003-509 341		0003-509 361		0003-509 561	
17	25	45	18000	0002-509 342		0002-509 362		0002-509 562	
25	25	50	18000	0002-509 343		0002-509 363		0002-509 563	
30	25	45	15000	0002-509 344		0002-509 364		0002-509 564	

Brushes Power drill

BRUSHES



End Brushes
crimped wire

PERFECT

End brushes for pin-point accuracy and hard-to-reach areas. DIY version.

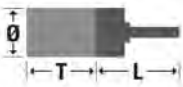

USAGE

	0,15	0,20	0,25/0,27	0,30	0,35	0,40	0,50
roughening	<input type="checkbox"/>	<input type="checkbox"/>	<input type="checkbox"/>	<input type="checkbox"/>	<input type="checkbox"/>	<input type="checkbox"/>	<input type="checkbox"/>
planing	<input type="checkbox"/>	<input type="checkbox"/>	<input type="checkbox"/>	<input type="checkbox"/>	<input type="checkbox"/>	<input type="checkbox"/>	<input type="checkbox"/>
deburring	<input type="checkbox"/>	<input type="checkbox"/>	<input type="checkbox"/>	<input type="checkbox"/>	<input type="checkbox"/>	<input type="checkbox"/>	<input type="checkbox"/>
edge honing	<input type="checkbox"/>	<input type="checkbox"/>	<input type="checkbox"/>	<input type="checkbox"/>	<input type="checkbox"/>	<input type="checkbox"/>	<input type="checkbox"/>
structuring	<input type="checkbox"/>	<input type="checkbox"/>	<input type="checkbox"/>	<input type="checkbox"/>	<input type="checkbox"/>	<input type="checkbox"/>	<input type="checkbox"/>
descaling/paint stripping	<input type="checkbox"/>	<input type="checkbox"/>	<input type="checkbox"/>	<input type="checkbox"/>	<input type="checkbox"/>	<input type="checkbox"/>	<input type="checkbox"/>
weld seams	<input type="checkbox"/>	<input type="checkbox"/>	<input type="checkbox"/>	<input type="checkbox"/>	<input type="checkbox"/>	<input type="checkbox"/>	<input type="checkbox"/>

TRIM AND MATERIAL

Products available with:

Steel wire crimped → Steel Cast steel Stainless steel Non-ferrous metal Aluminium Soft wood Hard wood

Stainless steel → Steel Cast steel Stainless steel Non-ferrous metal Aluminium Soft wood Hard wood

mm			rpm	pcs.	0,30	RRP	0,30	RRP		
Ø	T	L			Order-No.	€	Order-No.	€	Order-No.	€
12	20	45	4500	20	0008-509 161					
17	25	45	4500	12	0008-509 162					
25	25	50	4500	12			0008-509 363			
25	30	50	4500	12	0008-509 163					
30	35	50	4500	12	0008-509 164					

End Brushes
crimped wire

PERFECT

End brushes for pin-point accuracy and hard-to-reach areas. DIY version in self-service packaging.



USAGE

	0,15	0,20	0,25/0,27	0,30	0,35	0,40	0,50
roughening	<input type="checkbox"/>	<input type="checkbox"/>	<input type="checkbox"/>	<input type="checkbox"/>	<input type="checkbox"/>	<input type="checkbox"/>	<input type="checkbox"/>
planing	<input type="checkbox"/>	<input type="checkbox"/>	<input type="checkbox"/>	<input type="checkbox"/>	<input type="checkbox"/>	<input type="checkbox"/>	<input type="checkbox"/>
deburring	<input type="checkbox"/>	<input type="checkbox"/>	<input type="checkbox"/>	<input type="checkbox"/>	<input type="checkbox"/>	<input type="checkbox"/>	<input type="checkbox"/>
edge honing	<input type="checkbox"/>	<input type="checkbox"/>	<input type="checkbox"/>	<input type="checkbox"/>	<input type="checkbox"/>	<input type="checkbox"/>	<input type="checkbox"/>
structuring	<input type="checkbox"/>	<input type="checkbox"/>	<input type="checkbox"/>	<input type="checkbox"/>	<input type="checkbox"/>	<input type="checkbox"/>	<input type="checkbox"/>
descaling/paint stripping	<input type="checkbox"/>	<input type="checkbox"/>	<input type="checkbox"/>	<input type="checkbox"/>	<input type="checkbox"/>	<input type="checkbox"/>	<input type="checkbox"/>
weld seams	<input type="checkbox"/>	<input type="checkbox"/>	<input type="checkbox"/>	<input type="checkbox"/>	<input type="checkbox"/>	<input type="checkbox"/>	<input type="checkbox"/>

TRIM AND MATERIAL

Products available with:

Steel wire crimped → Steel Cast steel Stainless steel Non-ferrous metal Aluminium Soft wood Hard wood

Stainless steel → Steel Cast steel Stainless steel Non-ferrous metal Aluminium Soft wood Hard wood

mm				rpm	pcs.	0,30	RRP	0,30	RRP		
Ø	T	L	S			Order-No.	€	Order-No.	€	Order-No.	€
25	30	50	6	4500	12	1718-509 163		7008-509 363			

Brushes

Power drill

End Brushes
crimped wire
plastic-bonded



EVOLUTION



Brush with plastic-bonded wire for longer service life and reduced wire breakage.

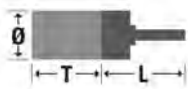

USAGE



	0,15	0,20	0,25/0,27	0,30	0,35	0,40	0,50
roughening	<input type="checkbox"/>	<input type="checkbox"/>	<input type="checkbox"/>	<input type="checkbox"/>	<input type="checkbox"/>	<input type="checkbox"/>	<input type="checkbox"/>
planing	<input type="checkbox"/>	<input type="checkbox"/>	<input type="checkbox"/>	<input type="checkbox"/>	<input type="checkbox"/>	<input type="checkbox"/>	<input type="checkbox"/>
deburring	<input type="checkbox"/>	<input type="checkbox"/>	<input type="checkbox"/>	<input type="checkbox"/>	<input type="checkbox"/>	<input type="checkbox"/>	<input type="checkbox"/>
edge honing	<input type="checkbox"/>	<input type="checkbox"/>	<input type="checkbox"/>	<input type="checkbox"/>	<input type="checkbox"/>	<input type="checkbox"/>	<input type="checkbox"/>
structuring	<input type="checkbox"/>	<input type="checkbox"/>	<input type="checkbox"/>	<input type="checkbox"/>	<input type="checkbox"/>	<input type="checkbox"/>	<input type="checkbox"/>
descaling/paint stripping	<input type="checkbox"/>	<input type="checkbox"/>	<input type="checkbox"/>	<input type="checkbox"/>	<input type="checkbox"/>	<input type="checkbox"/>	<input type="checkbox"/>
weld seams	<input type="checkbox"/>	<input type="checkbox"/>	<input type="checkbox"/>	<input type="checkbox"/>	<input type="checkbox"/>	<input type="checkbox"/>	<input type="checkbox"/>

TRIM AND MATERIAL

Products available with:

Steel wire crimped → Steel Cast steel Stainless steel Non-ferrous metal Aluminium Soft wood Hard wood

mm						0,30	RRP				
Ø	T	K	L	rpm	pcs.	Order-No.	€	Order-No.	€	Order-No.	€
17	24	16	43	15000	12	0002-930 902					
24	23	23	43	15000	12	0002-930 907					
31	23	29	43	15000	12	0002-930 912					

End Brushes
abrasive filament



PERFECT



The trim on these brushes follows the contours of the work piece without significantly affecting the surface. Brushes with abrasive bristles for cleaning materials.

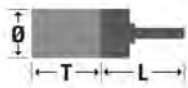

USAGE



	40/46	60	80	120	180	320	Fibre
roughening	<input type="checkbox"/>	<input type="checkbox"/>	<input type="checkbox"/>	<input type="checkbox"/>	<input type="checkbox"/>	<input type="checkbox"/>	<input type="checkbox"/>
planing	<input type="checkbox"/>	<input type="checkbox"/>	<input type="checkbox"/>	<input type="checkbox"/>	<input type="checkbox"/>	<input type="checkbox"/>	<input type="checkbox"/>
deburring	<input type="checkbox"/>	<input type="checkbox"/>	<input type="checkbox"/>	<input type="checkbox"/>	<input type="checkbox"/>	<input type="checkbox"/>	<input type="checkbox"/>
edge honing	<input type="checkbox"/>	<input type="checkbox"/>	<input type="checkbox"/>	<input type="checkbox"/>	<input type="checkbox"/>	<input type="checkbox"/>	<input type="checkbox"/>
structuring	<input type="checkbox"/>	<input type="checkbox"/>	<input type="checkbox"/>	<input type="checkbox"/>	<input type="checkbox"/>	<input type="checkbox"/>	<input type="checkbox"/>
descaling/paint stripping	<input type="checkbox"/>	<input type="checkbox"/>	<input type="checkbox"/>	<input type="checkbox"/>	<input type="checkbox"/>	<input type="checkbox"/>	<input type="checkbox"/>
weld seams	<input type="checkbox"/>	<input type="checkbox"/>	<input type="checkbox"/>	<input type="checkbox"/>	<input type="checkbox"/>	<input type="checkbox"/>	<input checked="" type="checkbox"/>

TRIM AND MATERIAL

Products available with:

Abrasive bristle → Steel Cast steel Stainless steel Non-ferrous metal Aluminium Soft wood Hard wood

mm						grit 80 red	RRP	grit 180 blue	RRP		
Ø	T	K	L	rpm	pcs.	Order-No.	€	Order-No.	€	Order-No.	€
25	25	22	45	5000	12	0812-509 913		1812-509 913			

Brushes Power drill

BRUSHES



End Brushes
abrasive filament

PERFECT

Do-it-yourself type for power drills in self-service packaging.



USAGE

	40/46	60	80	120	180	320	Fibre
roughening	<input checked="" type="checkbox"/>	<input checked="" type="checkbox"/>	<input checked="" type="checkbox"/>	<input checked="" type="checkbox"/>	<input checked="" type="checkbox"/>	<input checked="" type="checkbox"/>	<input type="checkbox"/>
planing	<input type="checkbox"/>	<input type="checkbox"/>	<input type="checkbox"/>	<input type="checkbox"/>	<input type="checkbox"/>	<input type="checkbox"/>	<input type="checkbox"/>
deburring	<input type="checkbox"/>	<input type="checkbox"/>	<input type="checkbox"/>	<input type="checkbox"/>	<input type="checkbox"/>	<input type="checkbox"/>	<input type="checkbox"/>
edge honing	<input type="checkbox"/>	<input type="checkbox"/>	<input type="checkbox"/>	<input type="checkbox"/>	<input type="checkbox"/>	<input type="checkbox"/>	<input type="checkbox"/>
structuring	<input type="checkbox"/>	<input type="checkbox"/>	<input type="checkbox"/>	<input type="checkbox"/>	<input type="checkbox"/>	<input type="checkbox"/>	<input type="checkbox"/>
descaling/paint stripping	<input type="checkbox"/>	<input type="checkbox"/>	<input type="checkbox"/>	<input type="checkbox"/>	<input type="checkbox"/>	<input type="checkbox"/>	<input type="checkbox"/>
weld seams	<input type="checkbox"/>	<input type="checkbox"/>	<input type="checkbox"/>	<input type="checkbox"/>	<input type="checkbox"/>	<input type="checkbox"/>	<input type="checkbox"/>

TRIM AND MATERIAL

Products available with:

Abrasive bristle → Steel Cast steel Stainless steel Non-ferrous metal Aluminium Soft wood Hard wood

mm						grit 80 red	RRP	grit 180 blue	RRP		
Ø	T	K	L	rpm	pcs.	Order-No.	€	Order-No.	€	Order-No.	€
25	25	22	45	5000	12	7812-509 913		7802-509 913			

End Brushes
abrasive filament

SPECIAL

End brushes with silicon carbide bristles
Professional, industrial quality version.

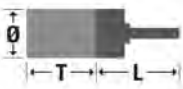

USAGE

	40/46	60	80	120	180	320	Fibre
roughening	<input checked="" type="checkbox"/>	<input checked="" type="checkbox"/>	<input checked="" type="checkbox"/>	<input checked="" type="checkbox"/>	<input checked="" type="checkbox"/>	<input checked="" type="checkbox"/>	<input type="checkbox"/>
planing	<input type="checkbox"/>	<input type="checkbox"/>	<input type="checkbox"/>	<input type="checkbox"/>	<input type="checkbox"/>	<input type="checkbox"/>	<input type="checkbox"/>
deburring	<input type="checkbox"/>	<input type="checkbox"/>	<input type="checkbox"/>	<input type="checkbox"/>	<input type="checkbox"/>	<input type="checkbox"/>	<input type="checkbox"/>
edge honing	<input type="checkbox"/>	<input type="checkbox"/>	<input type="checkbox"/>	<input type="checkbox"/>	<input type="checkbox"/>	<input type="checkbox"/>	<input type="checkbox"/>
structuring	<input type="checkbox"/>	<input type="checkbox"/>	<input type="checkbox"/>	<input type="checkbox"/>	<input type="checkbox"/>	<input type="checkbox"/>	<input type="checkbox"/>
descaling/paint stripping	<input type="checkbox"/>	<input type="checkbox"/>	<input type="checkbox"/>	<input type="checkbox"/>	<input type="checkbox"/>	<input type="checkbox"/>	<input type="checkbox"/>
weld seams	<input type="checkbox"/>	<input type="checkbox"/>	<input type="checkbox"/>	<input type="checkbox"/>	<input type="checkbox"/>	<input type="checkbox"/>	<input type="checkbox"/>

TRIM AND MATERIAL

Products available with:

Abrasive bristle → Steel Cast steel Stainless steel Non-ferrous metal Aluminium Soft wood Hard wood

mm						Novofil 120	RRP	Novofil 180	RRP	Novofil 320	RRP
Ø	T	K	L	rpm	pcs.	Order-No.	€	Order-No.	€	Order-No.	€
10	25	10	50	5000	12			1802-509 911		3202-509 911	
15	25	15	43	5000	12	1202-509 912		1802-509 912		3202-509 912	
22	25	22	50	5000	12	1202-509 913		1802-509 913		3202-509 913	
28	25	28	45	5000	12	1202-509 914		1802-509 914		3202-509 914	

Brushes

Power drill

Flap Wheel Brushes
crimped wire

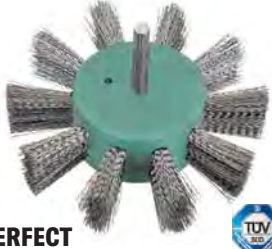

PERFECT 

Light and flexible flap wheel brushes with 25 mm operating width for power drills.

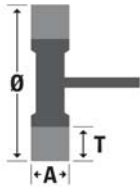

USAGE

	0,15	0,20	0,25/0,27	0,30	0,35	0,40	0,50
roughening	<input type="checkbox"/>	<input type="checkbox"/>	<input type="checkbox"/>	<input type="checkbox"/>	<input type="checkbox"/>	<input type="checkbox"/>	<input type="checkbox"/>
planing	<input type="checkbox"/>	<input type="checkbox"/>	<input type="checkbox"/>	<input type="checkbox"/>	<input type="checkbox"/>	<input type="checkbox"/>	<input type="checkbox"/>
deburring	<input type="checkbox"/>	<input type="checkbox"/>	<input type="checkbox"/>	<input type="checkbox"/>	<input type="checkbox"/>	<input type="checkbox"/>	<input type="checkbox"/>
edge honing	<input type="checkbox"/>	<input type="checkbox"/>	<input type="checkbox"/>	<input type="checkbox"/>	<input type="checkbox"/>	<input type="checkbox"/>	<input type="checkbox"/>
structuring	<input type="checkbox"/>	<input type="checkbox"/>	<input type="checkbox"/>	<input type="checkbox"/>	<input type="checkbox"/>	<input type="checkbox"/>	<input type="checkbox"/>
descaling/paint stripping	<input type="checkbox"/>	<input type="checkbox"/>	<input type="checkbox"/>	<input type="checkbox"/>	<input type="checkbox"/>	<input type="checkbox"/>	<input type="checkbox"/>
weld seams	<input type="checkbox"/>	<input type="checkbox"/>	<input type="checkbox"/>	<input type="checkbox"/>	<input type="checkbox"/>	<input type="checkbox"/>	<input type="checkbox"/>

TRIM AND MATERIAL

Products available with:

Steel wire crimped → Steel Cast steel Stainless steel Non-ferrous metal Aluminium Soft wood Hard wood

mm					0,30 steel wire	RRP	0,30 brass-coated	RRP		
Ø	A	T	rpm	pcs.	Order-No.	€	Order-No.	€	Order-No.	€
100	23	25	3500	5	0004-401 132		0004-401 052			

Flap Wheel Brushes
abrasive / natural fibre



PERFECT 

Light and flexible flap wheel brushes with 25 mm operating width for power drills.

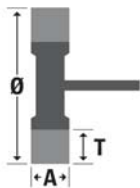

USAGE

	40/46	60	80	120	180	320	Fibre
roughening	<input type="checkbox"/>	<input type="checkbox"/>	<input type="checkbox"/>	<input type="checkbox"/>	<input type="checkbox"/>	<input type="checkbox"/>	<input type="checkbox"/>
planing	<input type="checkbox"/>	<input type="checkbox"/>	<input type="checkbox"/>	<input type="checkbox"/>	<input type="checkbox"/>	<input type="checkbox"/>	<input type="checkbox"/>
deburring	<input type="checkbox"/>	<input type="checkbox"/>	<input type="checkbox"/>	<input type="checkbox"/>	<input type="checkbox"/>	<input type="checkbox"/>	<input type="checkbox"/>
edge honing	<input type="checkbox"/>	<input type="checkbox"/>	<input type="checkbox"/>	<input type="checkbox"/>	<input type="checkbox"/>	<input type="checkbox"/>	<input type="checkbox"/>
structuring	<input type="checkbox"/>	<input type="checkbox"/>	<input type="checkbox"/>	<input type="checkbox"/>	<input type="checkbox"/>	<input type="checkbox"/>	<input type="checkbox"/>
descaling/paint stripping	<input type="checkbox"/>	<input type="checkbox"/>	<input type="checkbox"/>	<input type="checkbox"/>	<input type="checkbox"/>	<input type="checkbox"/>	<input type="checkbox"/>
weld seams	<input type="checkbox"/>	<input type="checkbox"/>	<input type="checkbox"/>	<input type="checkbox"/>	<input type="checkbox"/>	<input type="checkbox"/>	<input type="checkbox"/>

TRIM AND MATERIAL

Products available with:

Abrasive bristle → Steel Cast steel Stainless steel Non-ferrous metal Aluminium Soft wood Hard wood

Natural bristle → Steel Cast steel Stainless steel Non-ferrous metal Aluminium Soft wood Hard wood

mm					grit 80 red	RRP	grit 180 blue	RRP	fibre	RRP
Ø	A	T	rpm	pcs.	Order-No.	€	Order-No.	€	Order-No.	€
100	23	25	3500	5	0001-401 912		0011-401 912		0004-401 942	

Brushes Power drill

BRUSHES



Flap Wheel Brushes

abrasive / natural fibre

PERFECT

USAGE

	40/46								
roughening	<input checked="" type="checkbox"/>	<input checked="" type="checkbox"/>	<input checked="" type="checkbox"/>	<input checked="" type="checkbox"/>	<input checked="" type="checkbox"/>	<input checked="" type="checkbox"/>	<input checked="" type="checkbox"/>	<input checked="" type="checkbox"/>	<input checked="" type="checkbox"/>
planing	<input type="checkbox"/>	<input type="checkbox"/>	<input type="checkbox"/>	<input type="checkbox"/>	<input type="checkbox"/>	<input type="checkbox"/>	<input type="checkbox"/>	<input type="checkbox"/>	<input type="checkbox"/>
deburring	<input type="checkbox"/>	<input type="checkbox"/>	<input type="checkbox"/>	<input type="checkbox"/>	<input type="checkbox"/>	<input type="checkbox"/>	<input type="checkbox"/>	<input type="checkbox"/>	<input type="checkbox"/>
edge honing	<input type="checkbox"/>	<input type="checkbox"/>	<input type="checkbox"/>	<input type="checkbox"/>	<input type="checkbox"/>	<input type="checkbox"/>	<input type="checkbox"/>	<input type="checkbox"/>	<input type="checkbox"/>
structuring	<input type="checkbox"/>	<input type="checkbox"/>	<input type="checkbox"/>	<input type="checkbox"/>	<input type="checkbox"/>	<input type="checkbox"/>	<input type="checkbox"/>	<input type="checkbox"/>	<input type="checkbox"/>
descaling/paint stripping	<input type="checkbox"/>	<input type="checkbox"/>	<input type="checkbox"/>	<input type="checkbox"/>	<input type="checkbox"/>	<input type="checkbox"/>	<input type="checkbox"/>	<input type="checkbox"/>	<input type="checkbox"/>
weld seams	<input type="checkbox"/>	<input type="checkbox"/>	<input type="checkbox"/>	<input type="checkbox"/>	<input type="checkbox"/>	<input type="checkbox"/>	<input type="checkbox"/>	<input type="checkbox"/>	<input type="checkbox"/>

TRIM AND MATERIAL

Products available with:

Abrasive bristle	<input checked="" type="checkbox"/>	<input type="checkbox"/>	<input type="checkbox"/>	<input type="checkbox"/>	<input type="checkbox"/>	<input type="checkbox"/>	<input type="checkbox"/>	<input type="checkbox"/>	<input type="checkbox"/>
Natural bristle	<input type="checkbox"/>	<input type="checkbox"/>	<input type="checkbox"/>	<input type="checkbox"/>	<input type="checkbox"/>	<input type="checkbox"/>	<input type="checkbox"/>	<input type="checkbox"/>	<input type="checkbox"/>

mm					grit 80 red	RRP	grit 180 blue	RRP
Ø	A	T	rpm	pcs.	Order-No.	€	Order-No.	€
100	23	25	3500	5	7801-401 912		7811-401 912	

Do-it-yourself type for power drills in self-service packaging.

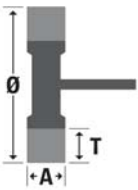

DIY Brush Set

5 pieces, crimped wire

PERFECT

USAGE

	0,15	0,20	0,25/0,27	0,30	0,35	0,40	0,50
roughening	<input type="checkbox"/>	<input type="checkbox"/>	<input type="checkbox"/>	<input type="checkbox"/>	<input type="checkbox"/>	<input type="checkbox"/>	<input type="checkbox"/>
planing	<input checked="" type="checkbox"/>	<input checked="" type="checkbox"/>	<input checked="" type="checkbox"/>	<input checked="" type="checkbox"/>	<input checked="" type="checkbox"/>	<input checked="" type="checkbox"/>	<input checked="" type="checkbox"/>
deburring	<input type="checkbox"/>	<input type="checkbox"/>	<input type="checkbox"/>	<input type="checkbox"/>	<input type="checkbox"/>	<input type="checkbox"/>	<input type="checkbox"/>
edge honing	<input type="checkbox"/>	<input type="checkbox"/>	<input type="checkbox"/>	<input type="checkbox"/>	<input type="checkbox"/>	<input type="checkbox"/>	<input type="checkbox"/>
structuring	<input type="checkbox"/>	<input type="checkbox"/>	<input type="checkbox"/>	<input type="checkbox"/>	<input type="checkbox"/>	<input type="checkbox"/>	<input type="checkbox"/>
descaling/paint stripping	<input type="checkbox"/>	<input type="checkbox"/>	<input type="checkbox"/>	<input type="checkbox"/>	<input type="checkbox"/>	<input type="checkbox"/>	<input type="checkbox"/>
weld seams	<input type="checkbox"/>	<input type="checkbox"/>	<input type="checkbox"/>	<input type="checkbox"/>	<input type="checkbox"/>	<input type="checkbox"/>	<input type="checkbox"/>

TRIM AND MATERIAL

Products available with:

Steel wire crimped	<input checked="" type="checkbox"/>	<input checked="" type="checkbox"/>	<input type="checkbox"/>	<input type="checkbox"/>	<input type="checkbox"/>	<input type="checkbox"/>	<input type="checkbox"/>	<input type="checkbox"/>
--------------------	-------------------------------------	-------------------------------------	--------------------------	--------------------------	--------------------------	--------------------------	--------------------------	--------------------------

		DIY brush set	RRP
rpm	pcs.	Order-No.	€
4500	10	1418-600 005	

0,30	Ø
wheel brush	50
wheel brush	75
end brush	25
cup brush	50
cup brush	70



Promotional set of five power drill brushes for metal processing in self-service packaging.

DIY Brush Set

5 pieces, abrasive filament

PERFECT

USAGE

	40/46								
roughening	<input checked="" type="checkbox"/>	<input checked="" type="checkbox"/>	<input checked="" type="checkbox"/>	<input checked="" type="checkbox"/>	<input checked="" type="checkbox"/>	<input checked="" type="checkbox"/>	<input checked="" type="checkbox"/>	<input checked="" type="checkbox"/>	<input checked="" type="checkbox"/>
planing	<input type="checkbox"/>	<input type="checkbox"/>	<input type="checkbox"/>	<input type="checkbox"/>	<input type="checkbox"/>	<input type="checkbox"/>	<input type="checkbox"/>	<input type="checkbox"/>	<input type="checkbox"/>
deburring	<input type="checkbox"/>	<input type="checkbox"/>	<input type="checkbox"/>	<input type="checkbox"/>	<input type="checkbox"/>	<input type="checkbox"/>	<input type="checkbox"/>	<input type="checkbox"/>	<input type="checkbox"/>
edge honing	<input type="checkbox"/>	<input type="checkbox"/>	<input type="checkbox"/>	<input type="checkbox"/>	<input type="checkbox"/>	<input type="checkbox"/>	<input type="checkbox"/>	<input type="checkbox"/>	<input type="checkbox"/>
structuring	<input type="checkbox"/>	<input type="checkbox"/>	<input type="checkbox"/>	<input type="checkbox"/>	<input type="checkbox"/>	<input type="checkbox"/>	<input type="checkbox"/>	<input type="checkbox"/>	<input type="checkbox"/>
descaling/paint stripping	<input type="checkbox"/>	<input type="checkbox"/>	<input type="checkbox"/>	<input type="checkbox"/>	<input type="checkbox"/>	<input type="checkbox"/>	<input type="checkbox"/>	<input type="checkbox"/>	<input type="checkbox"/>
weld seams	<input type="checkbox"/>	<input type="checkbox"/>	<input type="checkbox"/>	<input type="checkbox"/>	<input type="checkbox"/>	<input type="checkbox"/>	<input type="checkbox"/>	<input type="checkbox"/>	<input type="checkbox"/>

TRIM AND MATERIAL

Products available with:

Abrasive bristle	<input checked="" type="checkbox"/>	<input type="checkbox"/>	<input type="checkbox"/>	<input type="checkbox"/>	<input type="checkbox"/>	<input type="checkbox"/>	<input type="checkbox"/>	<input type="checkbox"/>	<input type="checkbox"/>
------------------	-------------------------------------	--------------------------	--------------------------	--------------------------	--------------------------	--------------------------	--------------------------	--------------------------	--------------------------

		DIY brush set	RRP
rpm	pcs.	Order-No.	€
4500	10	1518-600 005	

grit 80	Ø
wheel brush	50
wheel brush	75
end brush	25
cup brush	50
cup brush	75



Promotional set of five power drill brushes for woodworking in self-service packaging.

NEW!

Brushes

Power drill



		mm			RRP					
Ø	inch	F	S	pcs.	Order-No.	€	Order-No.	€	Order-No.	€
10		20	6	1	0003-000 100					
13		20	6	1	0003-000 130					
12,7	1/2 inch	20	6	1	0004-000 127					

For wheel brushes with arbor hole.
Brushes can be mounted up to a face width
of max. 20 mm.

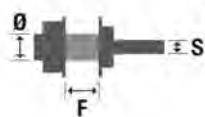

Brushes High-speed

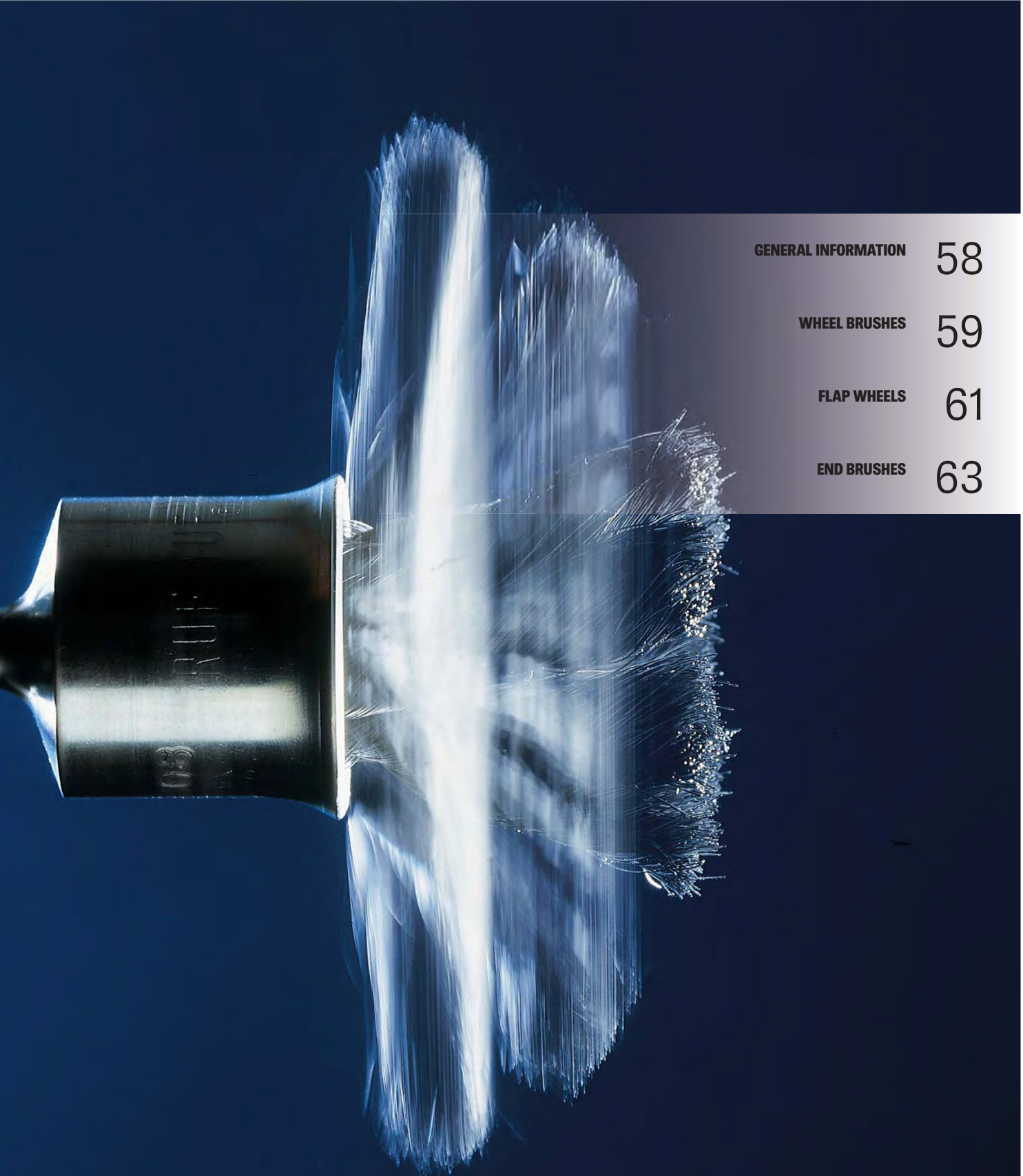

GENERAL INFORMATION 58

WHEEL BRUSHES 59

FLAP WHEELS 61

END BRUSHES 63

Brushes

High-speed



Important user information

Brushes for high-speed machines



To be noted when selecting brushes and using high-speed machines:

1. General user information

Thanks to their reinforced components and especially rigid clamping characteristics, the brushes on the following pages are suitable for high-speed drive units (e.g. straight grinders, pneumatic tools) and for all common brands.

2. Typical brushes for high-speed machines



Wheel brushes

Available with knotted and crimped wire.



End brushes

Available with knotted, abrasive and crimped wire, as well as extra-long shaft and special shapes.



Please note:

End brushes spread during operation.

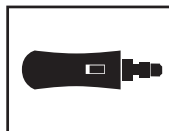

The machine information on the packaging and displays

Details on machine suitability can also be found on the machine icons on Osborn packaging and counter and shelf displays.

Wheel Brushes knotted wire



SPECIAL



For heavy-duty cleaning and deburring applications such as slag and silicate removal, weld seam finishing or removal of the underfloor protection in motor vehicles.

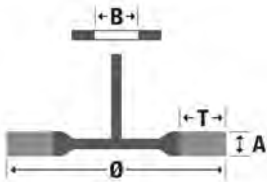

USAGE



	0,28	0,35	0,50	0,60	0,80
roughening	<input type="checkbox"/>	<input type="checkbox"/>	<input type="checkbox"/>	<input type="checkbox"/>	<input type="checkbox"/>
planing	<input type="checkbox"/>	<input type="checkbox"/>	<input type="checkbox"/>	<input type="checkbox"/>	<input type="checkbox"/>
deburring	<input checked="" type="checkbox"/>	<input checked="" type="checkbox"/>	<input checked="" type="checkbox"/>	<input checked="" type="checkbox"/>	<input checked="" type="checkbox"/>
edge honing	<input type="checkbox"/>	<input type="checkbox"/>	<input type="checkbox"/>	<input type="checkbox"/>	<input type="checkbox"/>
structuring	<input type="checkbox"/>	<input type="checkbox"/>	<input type="checkbox"/>	<input type="checkbox"/>	<input type="checkbox"/>
descaling/paint stripping	<input checked="" type="checkbox"/>	<input checked="" type="checkbox"/>	<input checked="" type="checkbox"/>	<input checked="" type="checkbox"/>	<input checked="" type="checkbox"/>
weld seams	<input checked="" type="checkbox"/>	<input checked="" type="checkbox"/>	<input checked="" type="checkbox"/>	<input checked="" type="checkbox"/>	<input checked="" type="checkbox"/>

TRIM AND MATERIAL

Products available with:

Steel wire twist knot	<input checked="" type="checkbox"/>	<input checked="" type="checkbox"/>	<input type="checkbox"/>	<input type="checkbox"/>	<input type="checkbox"/>	<input type="checkbox"/>	<input type="checkbox"/>
Stainless steel	<input type="checkbox"/>	<input type="checkbox"/>	<input checked="" type="checkbox"/>	<input checked="" type="checkbox"/>	<input checked="" type="checkbox"/>	<input type="checkbox"/>	<input type="checkbox"/>

mm				0,35	RRP	0,50	RRP	0,50	RRP			
Ø	A	T	B	Shank	rpm	pcs.	Order-No.	€	Order-No.	€	Order-No.	€
75	12	18		6	20000	12	0202-611 131		0202-611 151		0202-611 351	

Wheel Brushes crimped wire



SPECIAL



Recommended working speed approx. 50% of maximum RPM. For non-destructive and light cleaning work, deburring and processing bores.

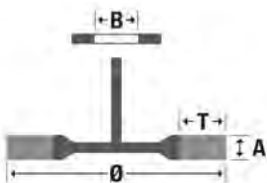

USAGE



	0,15	0,20	0,25/0,27	0,30	0,35	0,40	0,50
roughening	<input type="checkbox"/>	<input type="checkbox"/>	<input type="checkbox"/>	<input type="checkbox"/>	<input type="checkbox"/>	<input type="checkbox"/>	<input type="checkbox"/>
planing	<input type="checkbox"/>	<input type="checkbox"/>	<input type="checkbox"/>	<input type="checkbox"/>	<input type="checkbox"/>	<input type="checkbox"/>	<input type="checkbox"/>
deburring	<input checked="" type="checkbox"/>	<input checked="" type="checkbox"/>	<input checked="" type="checkbox"/>	<input checked="" type="checkbox"/>	<input checked="" type="checkbox"/>	<input checked="" type="checkbox"/>	<input checked="" type="checkbox"/>
edge honing	<input type="checkbox"/>	<input type="checkbox"/>	<input type="checkbox"/>	<input type="checkbox"/>	<input type="checkbox"/>	<input type="checkbox"/>	<input type="checkbox"/>
structuring	<input type="checkbox"/>	<input type="checkbox"/>	<input type="checkbox"/>	<input type="checkbox"/>	<input type="checkbox"/>	<input type="checkbox"/>	<input type="checkbox"/>
descaling/paint stripping	<input type="checkbox"/>	<input type="checkbox"/>	<input type="checkbox"/>	<input type="checkbox"/>	<input type="checkbox"/>	<input type="checkbox"/>	<input type="checkbox"/>
weld seams	<input checked="" type="checkbox"/>	<input checked="" type="checkbox"/>	<input checked="" type="checkbox"/>	<input checked="" type="checkbox"/>	<input checked="" type="checkbox"/>	<input checked="" type="checkbox"/>	<input checked="" type="checkbox"/>

TRIM AND MATERIAL

Products available with:

Steel wire crimped	<input checked="" type="checkbox"/>	<input checked="" type="checkbox"/>	<input type="checkbox"/>	<input type="checkbox"/>	<input type="checkbox"/>	<input type="checkbox"/>	<input type="checkbox"/>
Stainless steel	<input type="checkbox"/>	<input type="checkbox"/>	<input checked="" type="checkbox"/>	<input checked="" type="checkbox"/>	<input checked="" type="checkbox"/>	<input type="checkbox"/>	<input type="checkbox"/>
Brass wire	<input type="checkbox"/>	<input type="checkbox"/>	<input type="checkbox"/>	<input checked="" type="checkbox"/>	<input checked="" type="checkbox"/>	<input type="checkbox"/>	<input type="checkbox"/>

mm				0,15	RRP	0,20	RRP	0,30	RRP	
Ø	A	T	rpm	pcs.	Order-No.	€	Order-No.	€	Order-No.	€
20	6	4	20000	10	0002-501 132		0002-501 142			
20	9	4	20000	10			0002-501 143			
30	6	6	20000	10			0002-502 141			
30	9	6	20000	10	0002-502 132		0002-502 142			
30	12	6	20000	10			0002-502 143			
40	11	10	18000	10	0002-503 132		0002-503 142			
40	16	10	18000	10			0002-503 143			
50	10	13	15000	10			0002-504 141		0002-504 161	
50	17	13	15000	10	0002-504 132		0002-504 142		0002-504 162	
50	23	13	15000	10			0002-504 143		0002-504 163	
60	12	15	15000	10			0002-505 141		0002-505 161	
60	18	15	15000	10	0002-505 132		0002-505 142		0002-505 162	
70	11	15	15000	10			0002-506 141		0002-506 161	
70	18	15	15000	10	0002-506 132		0002-506 142		0002-506 162	
80	19	20	15000	10			0002-507 142		0002-507 162	

Continue next page.

Brushes

High-speed

Wheel Brushes
crimped wire



SPECIAL 

Recommended working speed approx. 50% of maximum RPM. For non-destructive and light cleaning work, deburring and processing bores.

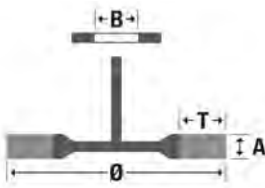

USAGE







	0,15	0,20	0,25/0,27	0,30	0,35	0,40	0,50
roughening	<input type="checkbox"/>	<input type="checkbox"/>	<input type="checkbox"/>	<input type="checkbox"/>	<input type="checkbox"/>	<input type="checkbox"/>	<input type="checkbox"/>
planing	<input type="checkbox"/>	<input type="checkbox"/>	<input type="checkbox"/>	<input type="checkbox"/>	<input type="checkbox"/>	<input type="checkbox"/>	<input type="checkbox"/>
deburring	<input type="checkbox"/>	<input type="checkbox"/>	<input type="checkbox"/>	<input type="checkbox"/>	<input type="checkbox"/>	<input type="checkbox"/>	<input type="checkbox"/>
edge honing	<input type="checkbox"/>	<input type="checkbox"/>	<input type="checkbox"/>	<input type="checkbox"/>	<input type="checkbox"/>	<input type="checkbox"/>	<input type="checkbox"/>
structuring	<input type="checkbox"/>	<input type="checkbox"/>	<input type="checkbox"/>	<input type="checkbox"/>	<input type="checkbox"/>	<input type="checkbox"/>	<input type="checkbox"/>
descaling/paint stripping	<input type="checkbox"/>	<input type="checkbox"/>	<input type="checkbox"/>	<input type="checkbox"/>	<input type="checkbox"/>	<input type="checkbox"/>	<input type="checkbox"/>
weld seams	<input type="checkbox"/>	<input type="checkbox"/>	<input type="checkbox"/>	<input type="checkbox"/>	<input type="checkbox"/>	<input type="checkbox"/>	<input type="checkbox"/>

TRIM AND MATERIAL

Products available with:

Steel wire crimped	<input checked="" type="checkbox"/>	<input type="checkbox"/>	<input type="checkbox"/>	<input type="checkbox"/>	<input type="checkbox"/>	<input type="checkbox"/>	<input type="checkbox"/>
Stainless steel	<input type="checkbox"/>	<input checked="" type="checkbox"/>	<input type="checkbox"/>	<input type="checkbox"/>	<input type="checkbox"/>	<input type="checkbox"/>	<input type="checkbox"/>
Brass wire	<input type="checkbox"/>	<input type="checkbox"/>	<input checked="" type="checkbox"/>	<input type="checkbox"/>	<input type="checkbox"/>	<input type="checkbox"/>	<input type="checkbox"/>

mm				0,15	RRP	0,20	RRP	0,30	RRP	
Ø	A	T	rpm	pcs.	Order-No.	€	Order-No.	€	Order-No.	€
30	6	6	20000	10			0002-502 341			
30	9	6	20000	10	0002-502 333		0002-502 342			
30	12	6	20000	10	0002-502 333		0002-502 343			
40	7	10	18000	10	0002-503 331		0002-503 341			
40	11	10	18000	10	0002-503 332		0002-503 342			
40	16	10	18000	10	0002-503 333		0002-503 343			
50	10	13	15000	10			0002-504 341		0002-504 361	
50	17	13	15000	10	0002-504 332		0002-504 342		0002-504 362	
50	23	13	15000	10			0002-504 343		0002-504 363	
60	12	15	15000	10			0002-505 341		0002-505 361	
60	18	15	15000	10	0002-505 332		0002-505 342		0002-505 362	
60	23	15	15000	10			0002-505 343		0002-505 363	
70	11	15	15000	10			0002-506 341		0002-506 361	
70	18	15	15000	10	0002-506 332		0002-506 342		0002-506 362	
70	23	15	15000	10			0002-506 343		0002-506 363	
80	10	20	12000	10					5162-507 361	
80	19	20	12000	10			0002-507 342		0002-507 362	

mm				0,20	RRP					
Ø	A	T	rpm	pcs.	Order-No.	€	Order-No.	€	Order-No.	€
30	9	6	20000	10	0002-502 542					
40	11	10	18000	10	0002-503 542					
50	17	13	15000	10	0002-504 542					
60	18	15	15000	10	0002-505 542					
70	18	15	15000	10	0002-506 542					
80	19	20	12000	10	0002-507 542					

Wheel Brushes
abrasive filament



SPECIAL

Silicon carbide abrasive bristle for deburring, edge rounding and surface finishing. Also suitable for non-ferrous metals.

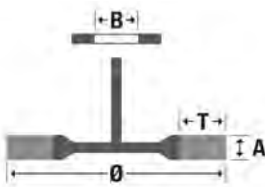

USAGE





	40/46	60	80	120	160	320	Fibre
roughening	<input checked="" type="checkbox"/>	<input type="checkbox"/>	<input type="checkbox"/>	<input type="checkbox"/>	<input type="checkbox"/>	<input type="checkbox"/>	<input type="checkbox"/>
planing	<input type="checkbox"/>	<input type="checkbox"/>	<input type="checkbox"/>	<input type="checkbox"/>	<input type="checkbox"/>	<input type="checkbox"/>	<input type="checkbox"/>
deburring	<input type="checkbox"/>	<input type="checkbox"/>	<input type="checkbox"/>	<input type="checkbox"/>	<input type="checkbox"/>	<input type="checkbox"/>	<input type="checkbox"/>
edge honing	<input type="checkbox"/>	<input type="checkbox"/>	<input type="checkbox"/>	<input type="checkbox"/>	<input type="checkbox"/>	<input type="checkbox"/>	<input type="checkbox"/>
structuring	<input type="checkbox"/>	<input type="checkbox"/>	<input type="checkbox"/>	<input type="checkbox"/>	<input type="checkbox"/>	<input type="checkbox"/>	<input type="checkbox"/>
descaling/paint stripping	<input type="checkbox"/>	<input type="checkbox"/>	<input type="checkbox"/>	<input type="checkbox"/>	<input type="checkbox"/>	<input type="checkbox"/>	<input type="checkbox"/>
weld seams	<input type="checkbox"/>	<input type="checkbox"/>	<input type="checkbox"/>	<input type="checkbox"/>	<input type="checkbox"/>	<input type="checkbox"/>	<input checked="" type="checkbox"/>

TRIM AND MATERIAL

Products available with:

Abrasive bristle	<input checked="" type="checkbox"/>	<input type="checkbox"/>	<input type="checkbox"/>	<input type="checkbox"/>	<input type="checkbox"/>	<input type="checkbox"/>	<input type="checkbox"/>
------------------	-------------------------------------	--------------------------	--------------------------	--------------------------	--------------------------	--------------------------	--------------------------

mm				grit 120	RRP	grit 180	RRP	grit 320	RRP		
Ø	A	T	B	rpm	pcs.	Order-No.	€	Order-No.	€	Order-No.	€
38	10	6	1/2"	20000	12	9906-011 146		9906-011 147		9906-011 148	
50	10	11	5/8"	15000	12	9906-011 149		9906-011 150		9906-011 151	
63	13	17	5/8"	15000	12	9906-011 153		9906-011 154		9906-011 155	

mm				grit 120	RRP	grit 180	RRP	grit 320	RRP		
Ø	A	T	S	rpm	pcs.	Order-No.	€	Order-No.	€	Order-No.	€
38	10	6	6	20000	10	9906-011 446		9906-011 447		9906-011 448	
50	10	11	6	15000	10	9906-011 449		9906-011 450		9906-011 451	
63	13	17	6	15000	10	9906-011 453		9906-011 454		9906-011 455	

Brushes High-speed

Flap Wheels



SPECIAL

Flap wheels are suited for surface finishing of most component parts out of steel, nonferrous metals, wood and hard plastics. With aluminium oxide.

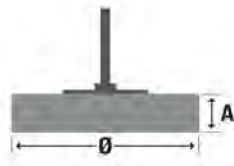

Ø	mm			rpm	pcs.	grit 40	RRP	grit 60	RRP	grit 80	RRP
	A	S	Order-No.			€	Order-No.	€	Order-No.	€	
30	10	6	25400	10	0043-003 010		0063-003 010		0083-003 010		
30	15	6	25400	10	0043-003 015		0063-003 015		0083-003 015		
40	15	6	19100	10	0043-004 015		0063-004 015		0083-004 015		
40	20	6	19100	10	0043-004 020		0063-004 020		0083-004 020		
40	30	6	17000	10	0063-004 030		0083-004 030		0123-004 030		
50	15	6	15200	10	0043-005 015		0063-005 015		0083-005 015		
50	20	6	15200	10	0043-005 020		0063-005 020		0083-005 020		
50	30	6	15200	10	0043-005 030		0063-005 030		0083-005 030		
60	20	6	12700	10	0043-006 020		0063-006 020		0083-006 020		
60	30	6	12700	10	0043-006 030		0063-006 030		0083-006 030		
60	40	6	12700	10	0043-006 040		0063-006 040		0083-006 040		
60	50	6	12700	10	0043-006 050		0063-006 050		0083-006 050		
80	30	6	8900	10	0043-008 030		0063-008 030		0083-008 030		
80	40	6	8900	10	0043-008 040		0063-008 040		0083-008 040		
80	50	6	8900	10	0043-008 050		0063-008 050		0083-008 050		

Ø	mm			rpm	pcs.	grit 120	RRP	grit 150	RRP	grit 180	RRP
	A	S	Order-No.			€	Order-No.	€	Order-No.	€	
30	10	6	25400	10	0123-003 010		0153-003 010		0183-003 010		
30	15	6	25400	10	0123-003 015		0153-003 015		0183-003 015		
40	15	6	19100	10	0123-004 015		0153-004 015		0183-004 015		
40	20	6	19100	10	0123-004 020		0153-004 020		0183-004 020		
50	15	6	15200	10	0123-005 015		0153-005 015		0183-005 015		
50	20	6	15200	10	0123-005 020		0153-005 020		0183-005 020		
50	30	6	15200	10	0123-005 030		0153-005 030		0183-005 030		
60	20	6	12700	10	0123-006 020		0153-006 020		0183-006 020		
60	30	6	12700	10	0123-006 030		0153-006 030		0183-006 030		
60	40	6	12700	10	0123-006 040		0153-006 040		0183-006 040		
60	50	6	12700	10	0123-006 050		0153-006 050		0183-006 050		
80	30	6	8900	10	0123-008 030		0153-008 030		0183-008 030		
80	40	6	8900	10	0123-008 040		0153-008 040		0183-008 040		
80	50	6	8900	10	0123-008 050		0153-008 050		0183-008 050		

Ø	mm			rpm	pcs.	grit 240	RRP			
	A	S	Order-No.			€	Order-No.	€	Order-No.	€
30	10	6	25400	10	0243-003 010					
30	15	6	25400	10	0243-003 015					
40	15	6	19100	10	0243-004 015					
40	20	6	19100	10	0243-004 020					
50	15	6	15200	10	0243-005 015					
50	20	6	15200	10	0243-005 020					
50	30	6	15200	10	0243-005 030					
60	20	6	12700	10	0243-006 020					
60	30	6	12700	10	0243-006 030					
60	40	6	12700	10	0243-006 040					
60	50	6	12700	10	0243-006 050					
80	30	6	8900	10	0243-008 030					
80	40	6	8900	10	0243-008 040					
80	50	6	8900	10	0243-008 050					

Brushes

High-speed

Flap Wheels of abrasive Fleece
non-woven combination



SPECIAL

Flap wheels with combined material: non-woven and abrasive cloth flaps for a fine surface pattern and as preparation for satinizing.

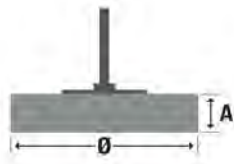

mm			max		grit 60	RRP	grit 80	RRP	grit 150	RRP
Ø	A	S	rpm	pcs.	Order-No.	€	Order-No.	€	Order-No.	€
40	20	6	17100	10	0063-404 020		0083-404 020		0153-404 020	
40	30	6	17100	10	0063-404 030		0083-404 030		0153-404 030	
50	20	6	13700	10	0063-405 020		0083-405 020		0153-405 020	
50	30	6	13700	10	0063-405 030		0083-405 030		0153-405 030	
50	40	6	13700	10	0063-405 040		0083-405 040		0153-405 040	
60	30	6	11500	10	0063-406 030		0083-406 030		0153-406 030	
60	40	6	11500	10	0063-406 040		0083-406 040		0153-406 040	
60	50	6	11500	10	0063-406 050		0083-406 050		0153-406 050	
80	40	6	8600	10	0063-408 040		0083-408 040		0153-408 040	
80	50	6	8600	10	0063-408 050		0083-408 050		0153-408 050	

mm			max		grit 240	RRP				
Ø	A	S	rpm	pcs.	Order-No.	€	Order-No.	€	Order-No.	€
40	20	6	17100	10	1243-404 020					
40	30	6	17100	10	1243-404 030					
50	20	6	13700	10	1243-405 020					
50	30	6	13700	10	1243-405 030					
50	40	6	13700	10	1243-405 040					
60	30	6	11500	10	1243-406 030					
60	40	6	11500	10	1243-406 040					
60	50	6	11500	10	1243-406 050					
80	40	6	8600	10	1243-408 040					
80	50	6	8600	10	1243-408 050					

Flap Wheels of abrasive Fleece



SPECIAL

Flap wheels of abrasive fleece are especially suited for surface cleaning. On metal surfaces, they produce a grinding finish with a high density. With aluminium oxide.

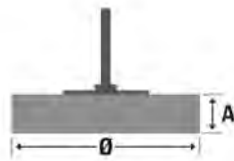

mm			max		coarse	RRP	medium	RRP	fine	RRP
Ø	A	S	rpm	pcs.	Order-No.	€	Order-No.	€	Order-No.	€
40	20	6	17100	10	0083-304 020		0153-304 020		0243-304 020	
40	30	6	17100	10	0083-304 030		0153-304 030		0243-304 030	
50	30	6	13700	10	0083-305 030		0153-305 030		0243-305 030	
50	40	6	13700	10	0083-305 040		0153-305 040		0243-305 040	
60	30	6	11500	10	0083-306 030		0153-306 030		0243-306 030	
60	50	6	11500	10	0083-306 050		0153-306 050		0243-306 050	
80	50	6	8600	10	0083-308 050		0153-308 050		0243-308 050	

mm			max		very fine	RRP				
Ø	A	S	rpm	pcs.	Order-No.	€	Order-No.	€	Order-No.	€
40	20	6	17100	10	0323-304 020					
40	30	6	17100	10	0323-304 030					
50	30	6	13700	10	0323-305 030					
50	40	6	13700	10	0323-305 040					
60	30	6	11500	10	0323-306 030					
60	50	6	11500	10	0323-306 050					
80	50	6	8600	10	0323-308 050					

Important:

Grit fleece	Comparable grit (FEPA)
coarse	80-120
medium	150-220
fine	240-360
very fine	400-600

Brushes High-speed

End Brushes
knotted wire



SPECIAL



USAGE





	0,26	0,35	0,50	0,60	0,80
roughening	<input type="checkbox"/>	<input type="checkbox"/>	<input type="checkbox"/>	<input type="checkbox"/>	<input type="checkbox"/>
planing	<input type="checkbox"/>	<input type="checkbox"/>	<input type="checkbox"/>	<input type="checkbox"/>	<input type="checkbox"/>
deburring	<input type="checkbox"/>	<input type="checkbox"/>	<input type="checkbox"/>	<input type="checkbox"/>	<input type="checkbox"/>
edge honing	<input type="checkbox"/>	<input type="checkbox"/>	<input type="checkbox"/>	<input type="checkbox"/>	<input type="checkbox"/>
structuring	<input type="checkbox"/>	<input type="checkbox"/>	<input type="checkbox"/>	<input type="checkbox"/>	<input type="checkbox"/>
descaling/paint stripping	<input type="checkbox"/>	<input type="checkbox"/>	<input type="checkbox"/>	<input type="checkbox"/>	<input type="checkbox"/>
weld seams	<input type="checkbox"/>	<input type="checkbox"/>	<input type="checkbox"/>	<input type="checkbox"/>	<input type="checkbox"/>

TRIM AND MATERIAL



Products available with:

Steel wire twist knot	<input checked="" type="checkbox"/>	<input checked="" type="checkbox"/>	<input type="checkbox"/>	<input type="checkbox"/>	<input type="checkbox"/>	<input type="checkbox"/>	<input type="checkbox"/>
Stainless steel	<input type="checkbox"/>	<input type="checkbox"/>	<input checked="" type="checkbox"/>	<input checked="" type="checkbox"/>	<input type="checkbox"/>	<input type="checkbox"/>	<input type="checkbox"/>

mm					0,26	RRP	0,35	RRP
Ø	T	L	rpm	pcs.	Order-No.	€	Order-No.	€
20	29	44	20000	12	0002-630 328			
23	29	44	20000	12	0002-630 334		0002-630 335	
30	29	44	20000	12	0002-630 340		0002-630 341	

Altering the RPMs means that the diameter can also be varied.



mm					0,26	RRP	0,35	RRP
Ø	T	L	rpm	pcs.	Order-No.	€	Order-No.	€
20	29	44	20000	12	0002-630 304		0002-630 305	
23	29	44	20000	12	0002-630 310		0002-630 311	
30	29	44	20000	12	0002-630 316		0002-630 317	

End Brushes
knotted Osborn wire



EVOLUTION



USAGE





	0,26	0,35	0,50	0,60	0,80
roughening	<input type="checkbox"/>	<input type="checkbox"/>	<input type="checkbox"/>	<input type="checkbox"/>	<input type="checkbox"/>
planing	<input type="checkbox"/>	<input type="checkbox"/>	<input type="checkbox"/>	<input type="checkbox"/>	<input type="checkbox"/>
deburring	<input type="checkbox"/>	<input type="checkbox"/>	<input type="checkbox"/>	<input type="checkbox"/>	<input type="checkbox"/>
edge honing	<input type="checkbox"/>	<input type="checkbox"/>	<input type="checkbox"/>	<input type="checkbox"/>	<input type="checkbox"/>
structuring	<input type="checkbox"/>	<input type="checkbox"/>	<input type="checkbox"/>	<input type="checkbox"/>	<input type="checkbox"/>
descaling/paint stripping	<input type="checkbox"/>	<input type="checkbox"/>	<input type="checkbox"/>	<input type="checkbox"/>	<input type="checkbox"/>
weld seams	<input type="checkbox"/>	<input type="checkbox"/>	<input type="checkbox"/>	<input type="checkbox"/>	<input type="checkbox"/>

TRIM AND MATERIAL

Products available with:

Steel wire twist knot	<input checked="" type="checkbox"/>	<input checked="" type="checkbox"/>	<input type="checkbox"/>	<input type="checkbox"/>	<input type="checkbox"/>	<input type="checkbox"/>	<input type="checkbox"/>
Stainless steel	<input type="checkbox"/>	<input type="checkbox"/>	<input checked="" type="checkbox"/>	<input checked="" type="checkbox"/>	<input type="checkbox"/>	<input type="checkbox"/>	<input type="checkbox"/>

mm					Osborn 0,15	RRP	Osborn 0,26	RRP	Osborn 0,35	RRP
Ø	L	T	S	rpm	pcs.	Order-No.	€	Order-No.	€	Order-No.
20	44	29	6	20000	12	9906-030 302		9906-030 304		9906-030 305
23	44	29	6	20000	12	9906-030 308		9906-030 310		9906-030 311
30	44	29	6	20000	12	9906-030 314		9906-030 316		9906-030 317

RUFTUF® with Original Osborn steel wire – a high performance wire developed by Osborn.



mm					Osborn 0,50	RRP
Ø	L	T	S	rpm	pcs.	Order-No.
23	44	29	6	20000	12	9906-030 312
30	44	29	6	20000	12	9906-030 318

Important:

Brushes flare during operation (see picture)

Information on the grade of flaring in relation to the body-diameter and operating speed, please see table.



Body-Ø	Wire size	At Speed ≤ min ⁻¹ 5000	At Speed ≤ min ⁻¹ 8000	At Speed ≤ min ⁻¹ 15000
20	0,26	55	70	75
20	0,35	25	50	70
23	0,26	40	65	75
23	0,35	35	55	70
30	0,26	55	70	85
30	0,35	50	70	80

Recommended operating speed approx. 50% of the maximum rpm.

Brushes

High-speed

End Brushes
knotted Osborn wire



EVOLUTION



USAGE



	0,26	0,35	0,50	0,60	0,80
roughening	<input type="checkbox"/>	<input type="checkbox"/>	<input type="checkbox"/>	<input type="checkbox"/>	<input type="checkbox"/>
planing	<input type="checkbox"/>	<input type="checkbox"/>	<input type="checkbox"/>	<input type="checkbox"/>	<input type="checkbox"/>
deburring	<input type="checkbox"/>	<input type="checkbox"/>	<input type="checkbox"/>	<input type="checkbox"/>	<input type="checkbox"/>
edge honing	<input type="checkbox"/>	<input type="checkbox"/>	<input type="checkbox"/>	<input type="checkbox"/>	<input type="checkbox"/>
structuring	<input type="checkbox"/>	<input type="checkbox"/>	<input type="checkbox"/>	<input type="checkbox"/>	<input type="checkbox"/>
descaling/paint stripping	<input type="checkbox"/>	<input type="checkbox"/>	<input type="checkbox"/>	<input type="checkbox"/>	<input type="checkbox"/>
weld seams	<input type="checkbox"/>	<input type="checkbox"/>	<input type="checkbox"/>	<input type="checkbox"/>	<input type="checkbox"/>

TRIM AND MATERIAL

Products available with:

Steel wire twist knot → Steel Cast steel Stainless steel Non-ferrous metal Aluminium Soft wood Hard wood

Stainless steel → Steel Cast steel Stainless steel Non-ferrous metal Aluminium Soft wood Hard wood

mm				rpm	pcs.	Osborn 0,15 *	RRP	Osborn 0,26 *	RRP	Osborn 0,35 *	RRP
Ø	L	T	S			Order-No.	€	Order-No.	€	Order-No.	€
20	44	29	6	20000	12	9906-030 326		9906-030 328		9906-030 329	
23	44	29	6	20000	12	9906-030 332		9906-030 334		9906-030 335	
30	44	29	6	20000	12	9906-030 338		9906-030 340		9906-030 341	

* stainless steel version degreased.

RUFTUF® with Original Osborn steel wire – a high performance wire developed by Osborn.

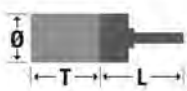

Important:
Brushes flare during operation (see picture)
Information on the grade of flaring in relation to the body-diameter and operating speed, please see table.

Body-Ø	Wire size	At Speed	At Speed	At Speed
		≤ min' 5000	≤ min' 8000	≤ min' 15000
20	0,26	55	70	75
20	0,35	25	50	70
23	0,26	40	65	75
23	0,35	35	55	70
30	0,26	55	70	85
30	0,35	50	70	80

Recommended operating speed approx. 50% of the maximum rpm.



i RUFTUF® end brushes are now also available with special rose bud twist. Available in steel wire and stainless steel wire, different wire diameters. Please contact us.

End Brushes

knotted wire



SPECIAL

Ideal for hard-to-reach areas. Extra-long tapered shank. Knotted wire.



USAGE

	0,26	0,35	0,50	0,60	0,80
roughening	<input type="checkbox"/>	<input type="checkbox"/>	<input type="checkbox"/>	<input type="checkbox"/>	<input type="checkbox"/>
planing	<input checked="" type="checkbox"/>	<input checked="" type="checkbox"/>	<input checked="" type="checkbox"/>	<input checked="" type="checkbox"/>	<input checked="" type="checkbox"/>
deburring	<input checked="" type="checkbox"/>	<input checked="" type="checkbox"/>	<input checked="" type="checkbox"/>	<input checked="" type="checkbox"/>	<input checked="" type="checkbox"/>
edge honing	<input checked="" type="checkbox"/>	<input checked="" type="checkbox"/>	<input checked="" type="checkbox"/>	<input checked="" type="checkbox"/>	<input checked="" type="checkbox"/>
structuring	<input checked="" type="checkbox"/>	<input checked="" type="checkbox"/>	<input checked="" type="checkbox"/>	<input checked="" type="checkbox"/>	<input checked="" type="checkbox"/>
descaling/paint stripping	<input checked="" type="checkbox"/>	<input checked="" type="checkbox"/>	<input checked="" type="checkbox"/>	<input checked="" type="checkbox"/>	<input checked="" type="checkbox"/>
weld seams	<input checked="" type="checkbox"/>	<input checked="" type="checkbox"/>	<input checked="" type="checkbox"/>	<input checked="" type="checkbox"/>	<input checked="" type="checkbox"/>

TRIM AND MATERIAL

Products available with:

	Steel	Cast steel	Stainless steel	Non-ferrous metal	Aluminium	Soft wood	Hard wood
Steel wire twist knot	<input checked="" type="checkbox"/>	<input checked="" type="checkbox"/>	<input type="checkbox"/>	<input type="checkbox"/>	<input type="checkbox"/>	<input type="checkbox"/>	<input type="checkbox"/>
Stainless steel	<input type="checkbox"/>	<input type="checkbox"/>	<input checked="" type="checkbox"/>	<input checked="" type="checkbox"/>	<input checked="" type="checkbox"/>	<input type="checkbox"/>	<input type="checkbox"/>

mm				0,25	RRP	0,35	RRP	0,50	RRP	
Ø	T	L	rpm	pcs.	Order-No.	€	Order-No.	€	Order-No.	€
10	26	72	15000	12	9803-630 151		9803-630 171		9803-630 101	

mm				0,25	RRP	0,35	RRP	0,50	RRP	
Ø	T	L	rpm	pcs.	Order-No.	€	Order-No.	€	Order-No.	€
10	26	72	15000	12	9803-630 351		9803-630 371		9803-630 301	

End Brushes

crimped wire



SPECIAL

Extra-long tapered shank.



USAGE

	0,15	0,20	0,25/0,27	0,30	0,35	0,40	0,50
roughening	<input type="checkbox"/>	<input type="checkbox"/>	<input type="checkbox"/>	<input type="checkbox"/>	<input type="checkbox"/>	<input type="checkbox"/>	<input type="checkbox"/>
planing	<input checked="" type="checkbox"/>	<input checked="" type="checkbox"/>	<input checked="" type="checkbox"/>	<input checked="" type="checkbox"/>	<input checked="" type="checkbox"/>	<input checked="" type="checkbox"/>	<input checked="" type="checkbox"/>
deburring	<input checked="" type="checkbox"/>	<input checked="" type="checkbox"/>	<input checked="" type="checkbox"/>	<input checked="" type="checkbox"/>	<input checked="" type="checkbox"/>	<input checked="" type="checkbox"/>	<input checked="" type="checkbox"/>
edge honing	<input checked="" type="checkbox"/>	<input checked="" type="checkbox"/>	<input checked="" type="checkbox"/>	<input checked="" type="checkbox"/>	<input checked="" type="checkbox"/>	<input checked="" type="checkbox"/>	<input checked="" type="checkbox"/>
structuring	<input checked="" type="checkbox"/>	<input checked="" type="checkbox"/>	<input checked="" type="checkbox"/>	<input checked="" type="checkbox"/>	<input checked="" type="checkbox"/>	<input checked="" type="checkbox"/>	<input checked="" type="checkbox"/>
descaling/paint stripping	<input checked="" type="checkbox"/>	<input checked="" type="checkbox"/>	<input checked="" type="checkbox"/>	<input checked="" type="checkbox"/>	<input checked="" type="checkbox"/>	<input checked="" type="checkbox"/>	<input checked="" type="checkbox"/>
weld seams	<input checked="" type="checkbox"/>	<input checked="" type="checkbox"/>	<input checked="" type="checkbox"/>	<input checked="" type="checkbox"/>	<input checked="" type="checkbox"/>	<input checked="" type="checkbox"/>	<input checked="" type="checkbox"/>

TRIM AND MATERIAL

Products available with:

	Steel	Cast steel	Stainless steel	Non-ferrous metal	Aluminium	Soft wood	Hard wood
Steel wire crimped	<input checked="" type="checkbox"/>	<input checked="" type="checkbox"/>	<input type="checkbox"/>	<input type="checkbox"/>	<input type="checkbox"/>	<input type="checkbox"/>	<input type="checkbox"/>
Stainless steel	<input type="checkbox"/>	<input type="checkbox"/>	<input checked="" type="checkbox"/>	<input checked="" type="checkbox"/>	<input checked="" type="checkbox"/>	<input type="checkbox"/>	<input type="checkbox"/>

mm				0,20	RRP	0,30	RRP	
Ø	T	L	rpm	pcs.	Order-No.	€	Order-No.	€
10	20	100	9000	10	0003-509 149		0003-509 169	

mm				0,20	RRP	0,30	RRP	
Ø	T	L	rpm	pcs.	Order-No.	€	Order-No.	€
10	20	100	9000	10	0003-509 349		0003-509 369	

Brushes

High-speed

End Brushes
crimped wire



SPECIAL

End brushes for pin-point accuracy and hard-to-reach areas. Professional version.



USAGE

	0,15	0,20	0,25/0,27	0,30	0,35	0,40	0,50
roughening	<input type="checkbox"/>	<input type="checkbox"/>	<input type="checkbox"/>	<input type="checkbox"/>	<input type="checkbox"/>	<input type="checkbox"/>	<input type="checkbox"/>
planing	<input type="checkbox"/>	<input type="checkbox"/>	<input type="checkbox"/>	<input type="checkbox"/>	<input type="checkbox"/>	<input type="checkbox"/>	<input type="checkbox"/>
deburring	<input type="checkbox"/>	<input type="checkbox"/>	<input type="checkbox"/>	<input type="checkbox"/>	<input type="checkbox"/>	<input type="checkbox"/>	<input type="checkbox"/>
edge honing	<input type="checkbox"/>	<input type="checkbox"/>	<input type="checkbox"/>	<input type="checkbox"/>	<input type="checkbox"/>	<input type="checkbox"/>	<input type="checkbox"/>
structuring	<input type="checkbox"/>	<input type="checkbox"/>	<input type="checkbox"/>	<input type="checkbox"/>	<input type="checkbox"/>	<input type="checkbox"/>	<input type="checkbox"/>
descaling/paint stripping	<input type="checkbox"/>	<input type="checkbox"/>	<input type="checkbox"/>	<input type="checkbox"/>	<input type="checkbox"/>	<input type="checkbox"/>	<input type="checkbox"/>
weld seams	<input type="checkbox"/>	<input type="checkbox"/>	<input type="checkbox"/>	<input type="checkbox"/>	<input type="checkbox"/>	<input type="checkbox"/>	<input type="checkbox"/>

TRIM AND MATERIAL

Products available with:

- Steel wire crimped → Steel, Cast steel, Stainless steel, Non-ferrous metal, Aluminium, Soft wood, Hard wood
- Stainless steel → Steel, Cast steel, Stainless steel, Non-ferrous metal, Aluminium, Soft wood, Hard wood
- Brass wire → Steel, Cast steel, Stainless steel, Non-ferrous metal, Aluminium, Soft wood, Hard wood

mm		max		0,20	RRP	0,30	RRP	0,50	RRP
Ø	T	L	rpm	Order-No.	€	Order-No.	€	Order-No.	€
10	20	40	20000	0003-509 141		0003-509 161		0003-509 191	
17	25	45	18000	0002-509 142		0002-509 162		0002-509 192	
25	25	50	18000	0002-509 143		0002-509 163		0002-509 193	
30	25	45	15000	0002-509 144		0002-509 164		0002-509 194	

mm		max		0,20	RRP	0,30	RRP	0,30	RRP
Ø	T	L	rpm	Order-No.	€	Order-No.	€	Order-No.	€
10	20	40	20000	0003-509 341		0003-509 361		0003-509 561	
17	25	45	18000	0002-509 342		0002-509 362		0002-509 562	
25	25	50	18000	0002-509 343		0002-509 363		0002-509 563	
30	25	45	15000	0003-509 561		0002-509 364		0002-509 564	

End Brushes
crimped wire



SPECIAL

Special design for dressing rounded welds or indentations.

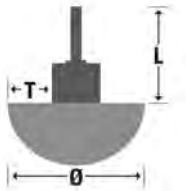

USAGE

	0,15	0,20	0,25/0,27	0,30	0,35	0,40	0,50
roughening	<input type="checkbox"/>	<input type="checkbox"/>	<input type="checkbox"/>	<input type="checkbox"/>	<input type="checkbox"/>	<input type="checkbox"/>	<input type="checkbox"/>
planing	<input type="checkbox"/>	<input type="checkbox"/>	<input type="checkbox"/>	<input type="checkbox"/>	<input type="checkbox"/>	<input type="checkbox"/>	<input type="checkbox"/>
deburring	<input type="checkbox"/>	<input type="checkbox"/>	<input type="checkbox"/>	<input type="checkbox"/>	<input type="checkbox"/>	<input type="checkbox"/>	<input type="checkbox"/>
edge honing	<input type="checkbox"/>	<input type="checkbox"/>	<input type="checkbox"/>	<input type="checkbox"/>	<input type="checkbox"/>	<input type="checkbox"/>	<input type="checkbox"/>
structuring	<input type="checkbox"/>	<input type="checkbox"/>	<input type="checkbox"/>	<input type="checkbox"/>	<input type="checkbox"/>	<input type="checkbox"/>	<input type="checkbox"/>
descaling/paint stripping	<input type="checkbox"/>	<input type="checkbox"/>	<input type="checkbox"/>	<input type="checkbox"/>	<input type="checkbox"/>	<input type="checkbox"/>	<input type="checkbox"/>
weld seams	<input type="checkbox"/>	<input type="checkbox"/>	<input type="checkbox"/>	<input type="checkbox"/>	<input type="checkbox"/>	<input type="checkbox"/>	<input type="checkbox"/>

TRIM AND MATERIAL

Products available with:

- Steel wire crimped → Steel, Cast steel, Stainless steel, Non-ferrous metal, Aluminium, Soft wood, Hard wood

mm		max		0,30	RRP		RRP		RRP
Ø	L	rpm	pcs.	Order-No.	€	Order-No.	€	Order-No.	€
50	45	15000	5	0002-509 165					
70	45	15000	5	0002-509 167					



End Brushes

crimped wire



SPECIAL

Flat shape, high form stability.



USAGE

	0,15	0,20	0,25/0,27	0,30	0,35	0,40	0,50
roughening	<input type="checkbox"/>	<input type="checkbox"/>	<input type="checkbox"/>	<input type="checkbox"/>	<input type="checkbox"/>	<input type="checkbox"/>	<input type="checkbox"/>
planing	<input type="checkbox"/>	<input type="checkbox"/>	<input type="checkbox"/>	<input type="checkbox"/>	<input type="checkbox"/>	<input type="checkbox"/>	<input type="checkbox"/>
deburring	<input type="checkbox"/>	<input type="checkbox"/>	<input type="checkbox"/>	<input type="checkbox"/>	<input type="checkbox"/>	<input type="checkbox"/>	<input type="checkbox"/>
edge honing	<input type="checkbox"/>	<input type="checkbox"/>	<input type="checkbox"/>	<input type="checkbox"/>	<input type="checkbox"/>	<input type="checkbox"/>	<input type="checkbox"/>
structuring	<input type="checkbox"/>	<input type="checkbox"/>	<input type="checkbox"/>	<input type="checkbox"/>	<input type="checkbox"/>	<input type="checkbox"/>	<input type="checkbox"/>
descaling/paint stripping	<input type="checkbox"/>	<input type="checkbox"/>	<input type="checkbox"/>	<input type="checkbox"/>	<input type="checkbox"/>	<input type="checkbox"/>	<input type="checkbox"/>
weld seams	<input type="checkbox"/>	<input type="checkbox"/>	<input type="checkbox"/>	<input type="checkbox"/>	<input type="checkbox"/>	<input type="checkbox"/>	<input type="checkbox"/>

TRIM AND MATERIAL

Products available with:

Steel wire crimped →

Stainless steel →

	Steel	Cast steel	Stainless steel	Non-ferrous metal	Aluminium	Soft wood	Hard wood
Steel wire crimped	<input checked="" type="checkbox"/>	<input checked="" type="checkbox"/>	<input type="checkbox"/>	<input type="checkbox"/>	<input type="checkbox"/>	<input type="checkbox"/>	<input type="checkbox"/>
Stainless steel	<input type="checkbox"/>	<input type="checkbox"/>	<input checked="" type="checkbox"/>	<input checked="" type="checkbox"/>	<input checked="" type="checkbox"/>	<input type="checkbox"/>	<input type="checkbox"/>

mm					0,40	RRP				
Ø	T	L	rpm	pcs.	Order-No.	€	Order-No.	€	Order-No.	€
8	29	57	12000	12	0024-509 101					
9,5	29	55	12000	12	0024-509 102					
10	27	158	12000	6	1224-509 101					
12	29	60	12000	12	0024-509 111					
12	55	55	12000	6	0014-509 102					
20	25	47	12000	6	0024-509 103					

End Brushes

straight/crimped wire



SPECIAL

Sharp shape, high stability.



USAGE

	0,15	0,20	0,25/0,27	0,30	0,35	0,40	0,50
roughening	<input type="checkbox"/>	<input type="checkbox"/>	<input type="checkbox"/>	<input type="checkbox"/>	<input type="checkbox"/>	<input type="checkbox"/>	<input type="checkbox"/>
planing	<input type="checkbox"/>	<input type="checkbox"/>	<input type="checkbox"/>	<input type="checkbox"/>	<input type="checkbox"/>	<input type="checkbox"/>	<input type="checkbox"/>
deburring	<input type="checkbox"/>	<input type="checkbox"/>	<input type="checkbox"/>	<input type="checkbox"/>	<input type="checkbox"/>	<input type="checkbox"/>	<input type="checkbox"/>
edge honing	<input type="checkbox"/>	<input type="checkbox"/>	<input type="checkbox"/>	<input type="checkbox"/>	<input type="checkbox"/>	<input type="checkbox"/>	<input type="checkbox"/>
structuring	<input type="checkbox"/>	<input type="checkbox"/>	<input type="checkbox"/>	<input type="checkbox"/>	<input type="checkbox"/>	<input type="checkbox"/>	<input type="checkbox"/>
descaling/paint stripping	<input type="checkbox"/>	<input type="checkbox"/>	<input type="checkbox"/>	<input type="checkbox"/>	<input type="checkbox"/>	<input type="checkbox"/>	<input type="checkbox"/>
weld seams	<input type="checkbox"/>	<input type="checkbox"/>	<input type="checkbox"/>	<input type="checkbox"/>	<input type="checkbox"/>	<input type="checkbox"/>	<input type="checkbox"/>

TRIM AND MATERIAL

Products available with:

Steel wire crimped →

Stainless steel →

	Steel	Cast steel	Stainless steel	Non-ferrous metal	Aluminium	Soft wood	Hard wood
Steel wire crimped	<input checked="" type="checkbox"/>	<input checked="" type="checkbox"/>	<input type="checkbox"/>	<input type="checkbox"/>	<input type="checkbox"/>	<input type="checkbox"/>	<input type="checkbox"/>
Stainless steel	<input type="checkbox"/>	<input type="checkbox"/>	<input checked="" type="checkbox"/>	<input checked="" type="checkbox"/>	<input checked="" type="checkbox"/>	<input type="checkbox"/>	<input type="checkbox"/>

mm					0,40	RRP	0,50	RRP			
Ø	T	L	Typ	rpm	pcs.	Order-No.	€	Order-No.	€	Order-No.	€
9,5	32	57	122 P	12000	12	0124-509 101					
10	27	125	121 P/L	7000	6	2224-509 101					
10	31	55	123 P	12000	12	0224-509 101					
12	30	61	124 P	12000	12	0124-509 111					
19	31	51	102 P	12000	6			0124-509 103			
19	64	50	225	12000	6			0024-509 100			

mm					0,30	RRP	0,50	RRP			
Ø	T	L	Typ	rpm	pcs.	Order-No.	€	Order-No.	€	Order-No.	€
9,5	32	57	122 P	12000	12	0074-509 301					
11	32	59	103 P	12000	6			0004-509 302 *			
19	31	51	102 P	12000	6			0124-509 303			
25	35	50	103 P	12000	6			0014-509 304			

* straight wire.

Brushes

High-speed

End Brushes
abrasive filament



EVOLUTION

USAGE



	40/46	60	80	120	180	320	Fibre
roughening	<input checked="" type="checkbox"/>	<input checked="" type="checkbox"/>	<input checked="" type="checkbox"/>	<input type="checkbox"/>	<input type="checkbox"/>	<input type="checkbox"/>	<input type="checkbox"/>
planing	<input type="checkbox"/>	<input type="checkbox"/>	<input type="checkbox"/>	<input checked="" type="checkbox"/>	<input checked="" type="checkbox"/>	<input checked="" type="checkbox"/>	<input type="checkbox"/>
deburring	<input type="checkbox"/>	<input type="checkbox"/>	<input type="checkbox"/>	<input checked="" type="checkbox"/>	<input checked="" type="checkbox"/>	<input checked="" type="checkbox"/>	<input type="checkbox"/>
edge honing	<input type="checkbox"/>	<input type="checkbox"/>	<input type="checkbox"/>	<input checked="" type="checkbox"/>	<input checked="" type="checkbox"/>	<input checked="" type="checkbox"/>	<input type="checkbox"/>
structuring	<input checked="" type="checkbox"/>	<input checked="" type="checkbox"/>	<input type="checkbox"/>	<input type="checkbox"/>	<input type="checkbox"/>	<input type="checkbox"/>	<input type="checkbox"/>
descaling/paint stripping	<input checked="" type="checkbox"/>	<input checked="" type="checkbox"/>	<input type="checkbox"/>	<input type="checkbox"/>	<input type="checkbox"/>	<input type="checkbox"/>	<input type="checkbox"/>
weld seams	<input type="checkbox"/>	<input type="checkbox"/>	<input type="checkbox"/>	<input type="checkbox"/>	<input type="checkbox"/>	<input type="checkbox"/>	<input checked="" type="checkbox"/>

TRIM AND MATERIAL

Products available with:

Abrasive bristle →

Steel	Cast steel	Stainless steel	Non-ferrous metal	Aluminium	Soft wood	Hard wood
<input checked="" type="checkbox"/>	<input checked="" type="checkbox"/>	<input checked="" type="checkbox"/>	<input checked="" type="checkbox"/>	<input checked="" type="checkbox"/>	<input checked="" type="checkbox"/>	<input checked="" type="checkbox"/>

mm						120	RRP	180	RRP	320	RRP
Ø	L	T	S	rpm	pcs.	Order-No.	€	Order-No.	€	Order-No.	€
10	45	25	6	8000	12	9906-030 488		9906-030 489		9906-030 490	
15	45	25	6	5000	12	9906-030 492		9906-030 493		9906-030 494	
22	45	25	6	5000	12	9906-030 496		9906-030 497		9906-030 498	
28	45	25	6	5000	12	9906-030 500		9906-030 501		9906-030 502	

Silicon carbide abrasive bristle for deburring, edge rounding and surface finishing. Also suitable for non-ferrous metals.

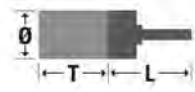

Machine brushes Satin finishing drums



GENERAL INFORMATION 70

SATIN FINISHING DRUMS 71

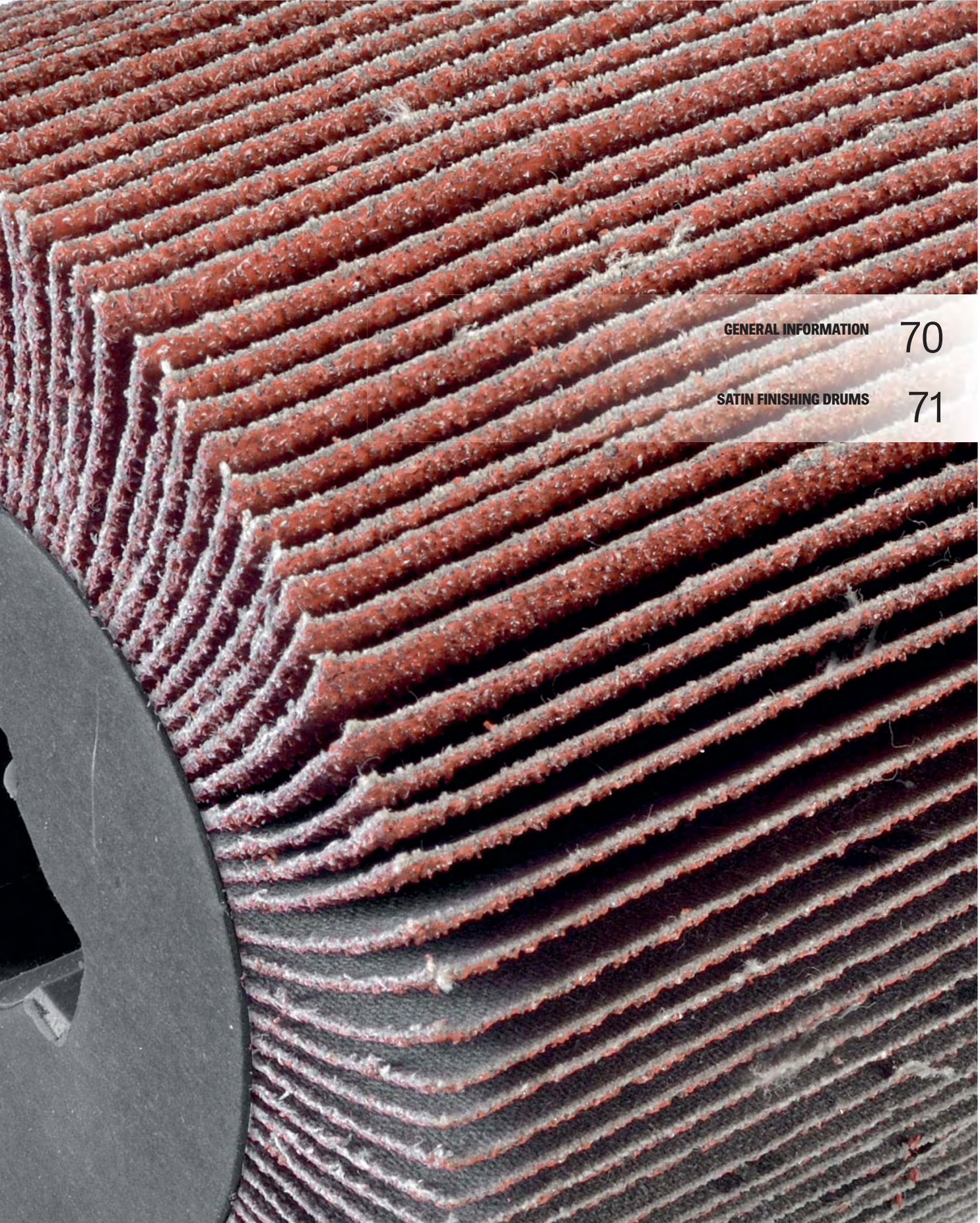

Machine brushes

Satin finishing drums – general information



Important user information

Satin finishing drums for satinisers



To be noted when selecting grinding tools and using satinisers:

Satinising is a one-stage system for creating flat surfaces. The main considerations when selecting the satinising tools is the question of how the original surface should look like after your finishing process.

There are three possible finishing grades when satinising a surface:

Coarse



Medium



Fine



1. General user information

These products can be fitted simply and easily thanks to their 19/6 bore (with 4 keyways) which suits all common satinisers.

2. Typical product for satinisers

Abrasive cloth rollers

Abrasive cloth rollers offer the advantages of a flexible abrasive cloth.

Thanks to their open and flexible structure, they conform perfectly to the workpiece being ground.

They are suitable for coarse, medium, fine and superfine grinding.

For pregrinding we recommend our satin finishing drums with grit 60/80 und 120.



3. Advantage of the cylinder shape

Peripheral grinding in comparison to face grinding makes for a very nice grinding surface pattern. The working width of 100 mm is in addition absolutely ideal to work larger surfaces.

Machine brushes

Satin finishing drums



Satin Finishing Drum

abrasive



Satin Finishing Drum with bore 19 and 4 keyways.
To be used for pre-grinding and structuring.
Can also be used for deburring.

mm		Ø	A	B	rpm	pcs.	grit 40	RRP	grit 60	RRP	grit 80	RRP
Ø	A	B	rpm	pcs.	Order-No.	€	Order-No.	€	Order-No.	€		
100	100	19	5700	1	0043-010 100		0063-010 100		0083-010 100			

mm		Ø	A	B	rpm	pcs.	grit 120	RRP	grit 180	RRP	grit 240	RRP
Ø	A	B	rpm	pcs.	Order-No.	€	Order-No.	€	Order-No.	€		
100	100	19	5700	1	0123-010 100		0183-010 100		0243-010 100			

Satin Finishing Drum

combined material



Satin Finishing Drum with combined material:
non-woven and abrasive cloth flaps for a fine
surface pattern and as preparation for satinizing.

mm		Ø	A	B	rpm	pcs.	K60/C	RRP	K80/M	RRP	K120/F	RRP
Ø	A	B	rpm	pcs.	Order-No.	€	Order-No.	€	Order-No.	€		
100	100	19	5700	1	0063-410 100		0083-410 100		0123-410 100			

mm		Ø	A	B	rpm	pcs.	K180/Vf	RRP				
Ø	A	B	rpm	pcs.	Order-No.	€	Order-No.	€	Order-No.	€		
100	100	19	5700	1	0183-410 100							

Satin Finishing Drum

non-woven



Drum with non-woven flaps.
To create a matt or satin finishing.

mm		Ø	A	B	rpm	pcs.	coarse	RRP	medium	RRP	very fine	RRP
Ø	A	B	rpm	pcs.	Order-No.	€	Order-No.	€	Order-No.	€		
100	100	19	5700	1	0083-310 100		0183-310 100		0283-310 100			

Machine brushes

Satin finishing drums



Roller brush for roughening, grinding and structuring of wood. Brushes used for brush sanders (e.g. Metabo, Eisenblätter, Makita, etc.). Please consider correct working width.

mm		⊙	max		Novofil NHS 60	RRP	Novofil NHS 80	RRP	Novofil NHS 120	RRP	
Ø	A	T	B	rpm	pcs.	Order-No.	€	Order-No.	€	Order-No.	€
100	100	20	19		1	6931-401 912		6941-401 912		6951-401 912	
100	120	20	12,7		1	8611-411 912		8601-411 912		3901-411 912	

mm		⊙	max		Novofil NHS 240	RRP					
Ø	A	T	B	rpm	pcs.	Order-No.	€	Order-No.	€	Order-No.	€
100	100	20	19		1	6961-401 912					
100	120	20	12,7		1	8641-411 912					



For roughening, deburring, cleaning of weld seams and paintstripping.

mm		⊙	max		cordwire 0,27	RRP	0,20	RRP			
Ø	A	T	B	rpm	pcs.	Order-No.	€	Order-No.	€	Order-No.	€
100	70	17,5	19	8000	1	9803-523 056		9803-523 346			

mm		⊙	max		0,30 crimped brass-coated	RRP	cordwire 0,27	RRP			
Ø	A	T	B	rpm	pcs.	Order-No.	€	Order-No.	€	Order-No.	€
100	120	16	12,7		1	4802-703 062		4802-703 052			



GENERAL INFORMATION 74

HAND SCRATCH BRUSHES 75

BUTCHERSBRUSHES 82

BROOMS 83

OTHERS 85

Hand brushes



Important user information

Brushes for manual use / hand brushes



To be noted when selecting brushes and using manual hand brushes:

1. General user information

Our hand brushes are suitable for all manual work such as deburring, cleaning, rust or paint removal. We also have brushes for various kinds of painting and decorating.

2. Typical brush types for manual use



Hand brushes

Available with wood or plastic body and handle.



Brooms

Available with wire or nylon trim, plus floor and scrubbing brushes.



Bristles

Available with flat, round and special bristles.



Accessories

We also have a selection of useful accessories.



Hand Scratch Brushes plastic handle



PERFECT

All-round brush with plastic handle for all sorts of cleaning applications.



USAGE

	wire crimped/smooth brass flat wire scratch strip Nylon/PVC natural bristle phosphorbronze
descaling/paint stripping	<input checked="" type="checkbox"/> <input type="checkbox"/> <input type="checkbox"/> <input type="checkbox"/> <input type="checkbox"/> <input type="checkbox"/> <input type="checkbox"/> <input type="checkbox"/>
weld seams	<input checked="" type="checkbox"/> <input type="checkbox"/> <input type="checkbox"/> <input type="checkbox"/> <input type="checkbox"/> <input type="checkbox"/> <input type="checkbox"/> <input type="checkbox"/>
etching	<input type="checkbox"/> <input type="checkbox"/> <input type="checkbox"/> <input checked="" type="checkbox"/> <input type="checkbox"/> <input type="checkbox"/> <input type="checkbox"/> <input type="checkbox"/>
brushing/dust removal	<input type="checkbox"/> <input type="checkbox"/> <input checked="" type="checkbox"/> <input checked="" type="checkbox"/> <input checked="" type="checkbox"/> <input checked="" type="checkbox"/> <input type="checkbox"/> <input type="checkbox"/>
painting	<input type="checkbox"/> <input type="checkbox"/> <input type="checkbox"/> <input type="checkbox"/> <input type="checkbox"/> <input type="checkbox"/> <input type="checkbox"/> <input type="checkbox"/>
light cleaning work	<input type="checkbox"/> <input checked="" type="checkbox"/> <input checked="" type="checkbox"/> <input checked="" type="checkbox"/> <input checked="" type="checkbox"/> <input checked="" type="checkbox"/> <input checked="" type="checkbox"/> <input checked="" type="checkbox"/>

TRIM AND MATERIAL

Products available with:

Steel wire	→	<input checked="" type="checkbox"/>	<input checked="" type="checkbox"/>	<input type="checkbox"/>	<input type="checkbox"/>	<input type="checkbox"/>	<input type="checkbox"/>
Stainless steel	→	<input type="checkbox"/>	<input type="checkbox"/>	<input checked="" type="checkbox"/>	<input checked="" type="checkbox"/>	<input checked="" type="checkbox"/>	<input type="checkbox"/>
Brass wire	→	<input type="checkbox"/>	<input type="checkbox"/>	<input type="checkbox"/>	<input checked="" type="checkbox"/>	<input checked="" type="checkbox"/>	<input type="checkbox"/>

mm					0,30 crimped	RRP	0,30 crimped	RRP	0,30 crimped	RRP
A	T	L	Rows	pcs.	Order-No.	€	Order-No.	€	Order-No.	€
140	25	265	1	24	0008-462 291		0008-462 391		0008-462 591	

mm					0,30 brass-coated	RRP
A	T	L	Rows	pcs.	Order-No.	€
140	25	265	1	24	0008-462 091	

Hand Scratch Brushes plastic handle

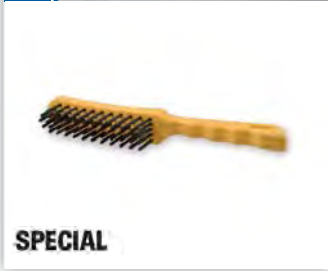

SPECIAL

Ergonomically shaped plastic handle. Dirt resistant.

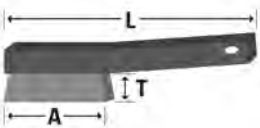

USAGE

	wire crimped/smooth brass flat wire scratch strip Nylon/PVC natural bristle phosphorbronze
descaling/paint stripping	<input checked="" type="checkbox"/> <input type="checkbox"/> <input type="checkbox"/> <input type="checkbox"/> <input type="checkbox"/> <input type="checkbox"/> <input type="checkbox"/> <input type="checkbox"/>
weld seams	<input checked="" type="checkbox"/> <input type="checkbox"/> <input type="checkbox"/> <input type="checkbox"/> <input type="checkbox"/> <input type="checkbox"/> <input type="checkbox"/> <input type="checkbox"/>
etching	<input type="checkbox"/> <input type="checkbox"/> <input type="checkbox"/> <input checked="" type="checkbox"/> <input type="checkbox"/> <input type="checkbox"/> <input type="checkbox"/> <input type="checkbox"/>
brushing/dust removal	<input type="checkbox"/> <input type="checkbox"/> <input checked="" type="checkbox"/> <input checked="" type="checkbox"/> <input checked="" type="checkbox"/> <input checked="" type="checkbox"/> <input type="checkbox"/> <input type="checkbox"/>
painting	<input type="checkbox"/> <input type="checkbox"/> <input type="checkbox"/> <input type="checkbox"/> <input type="checkbox"/> <input type="checkbox"/> <input type="checkbox"/> <input type="checkbox"/>
light cleaning work	<input type="checkbox"/> <input checked="" type="checkbox"/> <input checked="" type="checkbox"/> <input checked="" type="checkbox"/> <input checked="" type="checkbox"/> <input checked="" type="checkbox"/> <input checked="" type="checkbox"/> <input checked="" type="checkbox"/>

TRIM AND MATERIAL

Products available with:

Steel wire	→	<input checked="" type="checkbox"/>	<input checked="" type="checkbox"/>	<input type="checkbox"/>	<input type="checkbox"/>	<input type="checkbox"/>	<input type="checkbox"/>
Stainless steel	→	<input type="checkbox"/>	<input type="checkbox"/>	<input checked="" type="checkbox"/>	<input checked="" type="checkbox"/>	<input checked="" type="checkbox"/>	<input type="checkbox"/>
Brass wire	→	<input type="checkbox"/>	<input type="checkbox"/>	<input type="checkbox"/>	<input checked="" type="checkbox"/>	<input checked="" type="checkbox"/>	<input type="checkbox"/>

mm					0,35 straight	RRP	0,30 straight	RRP	0,20 crimped	RRP
A	T	L	Rows	pcs.	Order-No.	€	Order-No.	€	Order-No.	€
140	23	280	3	10	0008-462 133		0008-451 333		0008-447 573	
140	23	280	4	10	0008-462 134		0008-451 334		0008-447 574	

Hand brushes

Hand Scratch Brushes
plastic handle



SPECIAL

Hand scratch brushes with an ergonomic anti-slip handle. Washable.

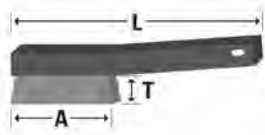

USAGE

descaling/paint stripping
 weld seams
 etching
 brushing/dust removal
 painting
 light cleaning work

wire crimped/smooth
 brass
 flat wire
 scratch strip
 Nylon/PVC
 natural bristle
 phosphorbronze

TRIM AND MATERIAL

Products available with:

Steel wire → Steel Cast steel Stainless steel Non-ferrous metal Aluminium Soft wood Hard wood

Stainless steel → Steel Cast steel Stainless steel Non-ferrous metal Aluminium Soft wood Hard wood

Brass wire → Steel Cast steel Stainless steel Non-ferrous metal Aluminium Soft wood Hard wood

mm					0,35 straight	RRP	0,30 straight	RRP	0,20 crimped	RRP
A	T	L	Rows	pcs.	Order-No.	€	Order-No.	€	Order-No.	€
110	23	270	3	5	0001-432 603		0001-432 613		0001-432 623	
110	23	270	4	5	0001-432 604		0001-432 614		0001-432 624	

Hand Scratch Brushes
plastic handle



SPECIAL

With anti-slip handle. Ideal shape to clean brake arches.

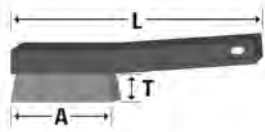

USAGE

descaling/paint stripping
 weld seams
 etching
 brushing/dust removal
 painting
 light cleaning work

wire crimped/smooth
 brass
 flat wire
 scratch strip
 Nylon/PVC
 natural bristle
 phosphorbronze

TRIM AND MATERIAL

Products available with:

Steel wire → Steel Cast steel Stainless steel Non-ferrous metal Aluminium Soft wood Hard wood

Brass wire → Steel Cast steel Stainless steel Non-ferrous metal Aluminium Soft wood Hard wood

mm					0,35 straight	RRP	0,30 crimped	RRP	0,30 crimped	RRP
A	T	L	Rows	pcs.	Order-No.	€	Order-No.	€	Order-No.	€
95	23	245	2	10	3301-462 122		3301-462 162		3301-462 562	

Hand Scratch Brushes

wooden handle



SPECIAL

Standardtype with quality hardwood body and pin hole.

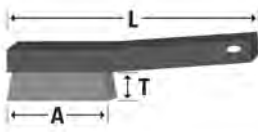

USAGE

	wire crimped/smooth	brass	flat wire	scratch strip	Nylon/PVC	natural bristle	phosphorbranza
descaling/paint stripping	<input type="checkbox"/>	<input type="checkbox"/>	<input type="checkbox"/>	<input type="checkbox"/>	<input type="checkbox"/>	<input type="checkbox"/>	<input type="checkbox"/>
weld seams	<input type="checkbox"/>	<input type="checkbox"/>	<input type="checkbox"/>	<input type="checkbox"/>	<input type="checkbox"/>	<input type="checkbox"/>	<input type="checkbox"/>
etching	<input type="checkbox"/>	<input type="checkbox"/>	<input type="checkbox"/>	<input type="checkbox"/>	<input type="checkbox"/>	<input type="checkbox"/>	<input type="checkbox"/>
brushing/dust removal	<input type="checkbox"/>	<input type="checkbox"/>	<input type="checkbox"/>	<input type="checkbox"/>	<input type="checkbox"/>	<input type="checkbox"/>	<input type="checkbox"/>
painting	<input type="checkbox"/>	<input type="checkbox"/>	<input type="checkbox"/>	<input type="checkbox"/>	<input type="checkbox"/>	<input type="checkbox"/>	<input type="checkbox"/>
light cleaning work	<input type="checkbox"/>	<input type="checkbox"/>	<input type="checkbox"/>	<input type="checkbox"/>	<input type="checkbox"/>	<input type="checkbox"/>	<input type="checkbox"/>

TRIM AND MATERIAL

Products available with:

	Steel	Cast steel	Stainless steel	Non-ferrous metal	Aluminium	Soft wood	Hard wood
Steel wire	<input checked="" type="checkbox"/>	<input type="checkbox"/>	<input type="checkbox"/>	<input type="checkbox"/>	<input type="checkbox"/>	<input type="checkbox"/>	<input type="checkbox"/>
Stainless steel	<input type="checkbox"/>	<input type="checkbox"/>	<input checked="" type="checkbox"/>	<input type="checkbox"/>	<input type="checkbox"/>	<input type="checkbox"/>	<input type="checkbox"/>
Brass wire	<input type="checkbox"/>	<input type="checkbox"/>	<input type="checkbox"/>	<input checked="" type="checkbox"/>	<input type="checkbox"/>	<input type="checkbox"/>	<input type="checkbox"/>

mm					0,30 straight brass-coated	RRP	0,35 straight steel wire	RRP		
A	T	L	Rows	pcs.	Order-No.	€	Order-No.	€	Order-No.	€
145	25	295	2	12	0001-152 022		0001-152 132			
145	25	295	3	12	0001-152 023		0001-152 133			
145	25	295	4	12	0001-152 024		0001-152 134			
145	25	295	5	12	0001-152 025		0001-152 135			
145	25	295	2	100			0001-151 132			
145	25	295	3	100			0001-151 133			
145	25	295	4	100			0001-151 134			
145	25	295	5	100			0001-151 135			

mm					0,30 straight	RRP	0,30 crimped	RRP	0,30 VA4 straight	RRP
A	T	L	Rows	pcs.	Order-No.	€	Order-No.	€	Order-No.	€
145	25	295	2	12	0001-151 332		0001-151 392		0001-152 332	
145	25	295	3	12	0001-151 333		0001-151 393		0001-152 333	
145	25	295	4	12	0001-151 334		0001-151 394		0001-152 334	
145	25	295	5	12	0001-151 335		0001-151 395		0001-152 335	

mm					0,30 straight	RRP	0,30 crimped	RRP		
A	T	L	Rows	pcs.	Order-No.	€	Order-No.	€	Order-No.	€
145	25	295	2	12	0001-158 522		0001-150 592			
145	25	295	3	12	0001-158 523		0001-150 593			
145	25	295	4	12	0001-158 524		0001-150 594			
145	25	295	5	12	0001-158 525		0001-150 595			

HAND BRUSHES

Hand Scratch Brushes

wooden handle



SPECIAL

Standardtype with quality hardwood body and pin hole. Sturdy professional version.



USAGE

	wire crimped/smooth	brass	flat wire	scratch strip	Nylon/PVC	natural bristle	phosphorbranza
descaling/paint stripping	<input type="checkbox"/>	<input type="checkbox"/>	<input type="checkbox"/>	<input type="checkbox"/>	<input type="checkbox"/>	<input type="checkbox"/>	<input type="checkbox"/>
weld seams	<input type="checkbox"/>	<input type="checkbox"/>	<input type="checkbox"/>	<input type="checkbox"/>	<input type="checkbox"/>	<input type="checkbox"/>	<input type="checkbox"/>
etching	<input type="checkbox"/>	<input type="checkbox"/>	<input type="checkbox"/>	<input type="checkbox"/>	<input type="checkbox"/>	<input type="checkbox"/>	<input type="checkbox"/>
brushing/dust removal	<input type="checkbox"/>	<input type="checkbox"/>	<input type="checkbox"/>	<input type="checkbox"/>	<input type="checkbox"/>	<input type="checkbox"/>	<input type="checkbox"/>
painting	<input type="checkbox"/>	<input type="checkbox"/>	<input type="checkbox"/>	<input type="checkbox"/>	<input type="checkbox"/>	<input type="checkbox"/>	<input type="checkbox"/>
light cleaning work	<input type="checkbox"/>	<input type="checkbox"/>	<input type="checkbox"/>	<input type="checkbox"/>	<input type="checkbox"/>	<input type="checkbox"/>	<input type="checkbox"/>

TRIM AND MATERIAL

Products available with:

	Steel	Cast steel	Stainless steel	Non-ferrous metal	Aluminium	Soft wood	Hard wood
Steel wire	<input checked="" type="checkbox"/>	<input type="checkbox"/>	<input type="checkbox"/>	<input type="checkbox"/>	<input type="checkbox"/>	<input type="checkbox"/>	<input type="checkbox"/>
Stainless steel	<input type="checkbox"/>	<input type="checkbox"/>	<input checked="" type="checkbox"/>	<input type="checkbox"/>	<input type="checkbox"/>	<input type="checkbox"/>	<input type="checkbox"/>
Brass wire	<input type="checkbox"/>	<input type="checkbox"/>	<input type="checkbox"/>	<input checked="" type="checkbox"/>	<input type="checkbox"/>	<input type="checkbox"/>	<input type="checkbox"/>

mm					0,35 straight	RRP	0,30 straight	RRP	0,30 straight	RRP
A	T	L	Rows	pcs.	Order-No.	€	Order-No.	€	Order-No.	€
160	30	310	3	12	0901-151 093		0901-152 333		0901-151 593	
160	30	310	4	12	0901-151 094		0901-152 334		0901-151 594	
160	30	310	5	12	0901-151 095		0901-152 335		0901-151 595	

Hand brushes

Hand Scratch Brushes
wooden handle



SPECIAL

Perfect brush shape for hollow welds.



USAGE

descaling/paint stripping
 weld seams
 etching
 brushing/dust removal
 painting
 light cleaning work

wire crimped/smooth
 brass
 flat wire
 scratch strip
 Nylon/PVC
 natural bristle
 phosphorbronze

TRIM AND MATERIAL

Products available with:

Steel wire → Steel Cast steel Stainless steel Non-ferrous metal Aluminium Soft wood Hard wood

Stainless steel → Steel Cast steel Stainless steel Non-ferrous metal Aluminium Soft wood Hard wood

mm					0,35 straight	RRP	0,35 straight	RRP		
A	T	L	Rows	pcs.	Order-No.	€	Order-No.	€	Order-No.	€
145	35	295	3	12	0003-162 133		0003-162 333			

Fine Scratch Brush
wooden handle



SPECIAL

Fine scratch brushes for soft and delicate cleaning work.



USAGE

descaling/paint stripping
 weld seams
 etching
 brushing/dust removal
 painting
 light cleaning work

wire crimped/smooth
 brass
 flat wire
 scratch strip
 Nylon/PVC
 natural bristle
 phosphorbronze

TRIM AND MATERIAL

Products available with:

Brass wire → Steel Cast steel Stainless steel Non-ferrous metal Aluminium Soft wood Hard wood

Natural bristle → Steel Cast steel Stainless steel Non-ferrous metal Aluminium Soft wood Hard wood

mm					0,20 crimped	RRP	horsehair	RRP		
A	T	L	Rows	B	Order-No.	€	Order-No.	€	Order-No.	€
105	18	220	4	22	0003-165 584		0003-165 964			

Spark Plug Brushes

wooden handle



SPECIAL

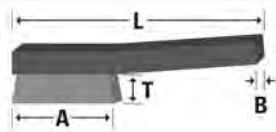

USAGE

	wire crimped/smooth	<input type="checkbox"/>
	brass	<input type="checkbox"/>
	flat wire	<input type="checkbox"/>
	scratch strip	<input type="checkbox"/>
	Nylon/PVC	<input type="checkbox"/>
	natural bristle	<input type="checkbox"/>
	phosphorbronze	<input type="checkbox"/>
descaling/paint stripping	<input type="checkbox"/>	<input type="checkbox"/>
weld seams	<input type="checkbox"/>	<input type="checkbox"/>
etching	<input type="checkbox"/>	<input type="checkbox"/>
brushing/dust removal	<input type="checkbox"/>	<input type="checkbox"/>
painting	<input type="checkbox"/>	<input type="checkbox"/>
light cleaning work	<input type="checkbox"/>	<input type="checkbox"/>

TRIM AND MATERIAL

Products available with:

Brass wire	<input checked="" type="checkbox"/>	Steel	<input type="checkbox"/>	Cast steel	<input type="checkbox"/>	Stainless steel	<input type="checkbox"/>	Non-ferrous metal	<input type="checkbox"/>	Aluminium	<input type="checkbox"/>	Soft wood	<input type="checkbox"/>	Hard wood	<input type="checkbox"/>
------------	-------------------------------------	-------	--------------------------	------------	--------------------------	-----------------	--------------------------	-------------------	--------------------------	-----------	--------------------------	-----------	--------------------------	-----------	--------------------------

mm



0,20 crimped

RRP

A	T	L	Rows	B	pcs.	Order-No.	€	Order-No.	€	Order-No.	€
45	18	189	3	18	24	0003-133 573					

Spark Plug Brushes

plastic handle



SPECIAL

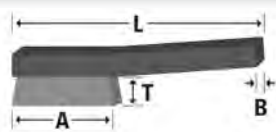

USAGE

	wire crimped/smooth	<input type="checkbox"/>
	brass	<input type="checkbox"/>
	flat wire	<input type="checkbox"/>
	scratch strip	<input type="checkbox"/>
	Nylon/PVC	<input type="checkbox"/>
	natural bristle	<input type="checkbox"/>
	phosphorbronze	<input type="checkbox"/>
descaling/paint stripping	<input type="checkbox"/>	<input type="checkbox"/>
weld seams	<input type="checkbox"/>	<input type="checkbox"/>
etching	<input type="checkbox"/>	<input type="checkbox"/>
brushing/dust removal	<input type="checkbox"/>	<input type="checkbox"/>
painting	<input type="checkbox"/>	<input type="checkbox"/>
light cleaning work	<input type="checkbox"/>	<input type="checkbox"/>

TRIM AND MATERIAL

Products available with:

Brass wire	<input checked="" type="checkbox"/>	Steel	<input type="checkbox"/>	Cast steel	<input type="checkbox"/>	Stainless steel	<input type="checkbox"/>	Non-ferrous metal	<input type="checkbox"/>	Aluminium	<input type="checkbox"/>	Soft wood	<input type="checkbox"/>	Hard wood	<input type="checkbox"/>
------------	-------------------------------------	-------	--------------------------	------------	--------------------------	-----------------	--------------------------	-------------------	--------------------------	-----------	--------------------------	-----------	--------------------------	-----------	--------------------------

mm



0,20 crimped

RRP

A	T	L	Rows	B	pcs.	Order-No.	€	Order-No.	€	Order-No.	€
33	15	180	3		48	0008-432 573					

Hand brushes

Battery Terminal Brushes
steel wire



SPECIAL

To clean batteries (pole and clamp cleaning).



mm			pcs.	steel wire crimped	RRP				
Ø	T	L		Order-No.	€	Order-No.	€	Order-No.	€
15/ 25	65	120	12	0008-493 100					

Fitting Brushes
steel wire



SPECIAL

To clean the inside of tubes and solder fittings made of copper or red brass.



mm			pcs.	0,20 steel wire	RRP				
Ø	A	L		Order-No.	€	Order-No.	€	Order-No.	€
13	25	160	12	0003-075 252					
16	25	160	12	0003-075 253					
19	28	160	12	0003-075 254					
23	25	160	12	0003-075 255					

Hole Cleaning Brushes

crimped wire



SPECIAL

To clean the inside of steel, wood or plastic products. To remove chippings and loose particles.

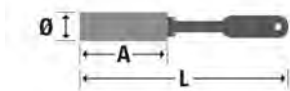

mm				0,20	RRP				
Ø	A	L	pcs.	Order-No.	€	Order-No.	€	Order-No.	€
15	100	280	10	0002-892 215					
20	100	280	10	0002-892 220					
25	100	280	10	0002-892 225					

File Brushes

wooden handle



SPECIAL

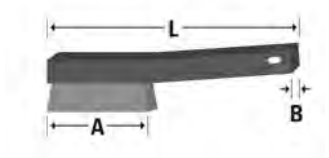

USAGE

descaling/paint stripping weld seams etching brushing/dust removal painting light cleaning work

wire crimped/smooth
 brass
 flat wire
 scratch strip
 Nylon/PVC
 natural bristle
 phosphorbronze

TRIM AND MATERIAL

Products available with:

Steel wire → Steel Cast steel Stainless steel Non-ferrous metal Aluminium Soft wood Hard wood

mm				straight	RRP				
B	L	A	pcs.	Order-No.	€	Order-No.	€	Order-No.	€
28	240	100	12	0003-140 101					
40	250	110	12	0003-140 102					
12	260	105	12	3303-140 101 *					

* without pin hole

Hand brushes

Butchersbrushes
wooden body



SPECIAL

Wood body with plastic handle.

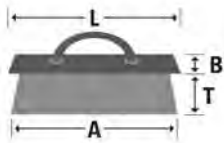

USAGE

TRIM AND MATERIAL

Products available with:

Steel wire Steel Cast steel Stainless steel Non-ferrous metal Aluminium Soft wood Hard wood

mm						0,35 straight	RRP	0,35 straight	RRP		
A	T	L	B	Rows	pcs.	Order-No.	€	Order-No.	€	Order-No.	€
190	40	205	60	5	10	0281-307 095 *		7601-306 095			

* with board

Butchersbrushes
wooden body



SPECIAL

Violin shape.

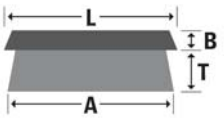

USAGE

TRIM AND MATERIAL

Products available with:

Steel wire Steel Cast steel Stainless steel Non-ferrous metal Aluminium Soft wood Hard wood

Stainless steel

mm						0,35 straight	RRP	0,30 straight brass-coated	RRP	flat wire 1,2x0,25	RRP
A	T	L	Rows	pcs.	Order-No.	€	Order-No.	€	Order-No.	€	
150	35	190	5	10							
170	35	210	5	10	0001-179 097		0001-179 297		0023-179 197		

Weed Brushes

wooden handle



Brush with v-shaped wire-configuration. Removal of moss and weeds on pavements and cobbled zones. With and without bore for handle.

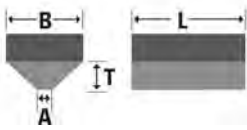

mm						0,35	RRP	0,35	RRP		
A	T	L	B	Rows	pcs.	Order-No.	€	Order-No.	€	Order-No.	€
4	38	100	35	3	25	0001-261 173 *		0011-261 173			

* with bore 24 mm.

Brooms

wooden body



mm						0,75 x 0,25 flat wire	RRP	1,20 x 0,25 flat wire	RRP	0,50 steel wire	RRP
T	L	B	Rows	pcs.	Order-No.	€	Order-No.	€	Order-No.	€	
75	300	60	5	10						0001-102 095	
75	300	60	6	10	0001-102 006		0001-102 016				

Hand brushes

Brooms wooden body

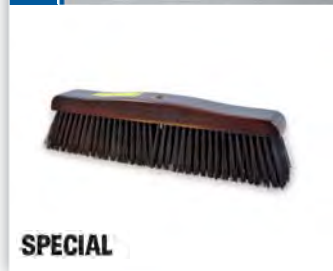

Type with Korfil-D to clean very dirty workshop floors.



mm						Korfil-D	RRP			
T	L	B	Rows	pcs.	Order-No.	€	Order-No.	€	Order-No.	€
75	400	60	6	1	0001-104 924 *					
75	700	70	7	1	9711-104 925					

* wooden body coated

Handle Holders metal



For workshop brooms. Order no. 9711-104 925.

	RRP					
pcs.	Order-No.	€	Order-No.	€	Order-No.	€
1	0003-000 001					

Brooms wooden body

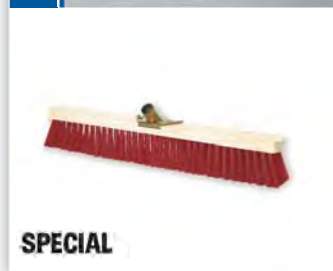

With handle holder, diameter 28 mm.

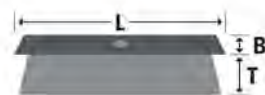

mm						Cocos	RRP	Elaston Red	RRP		
T	L	Rows	B	pcs.	Order-No.	€	Order-No.	€	Order-No.	€	
75	320		66	5			0004-102 925				
80	290	20	55	20	0003-102 950						
80	600	6	55	6	0003-102 990		0003-102 960				

Scrub Brushes

wooden body



mm				pcs.	steel wire straight	RRP					
T	L	B	Rows		Order-No.	€	Order-No.	€	Order-No.	€	
30	210	60	6	10	0001-122 096						
40	210	60	7	10	0001-120 097						

Dusters

wooden handle

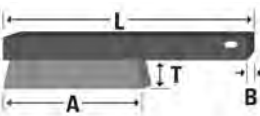
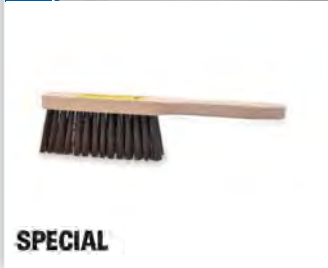

mm						à	steel wire straight	RRP		Korfil-D	RRP	
A	T	L	B	Rows	Order-No.		€	Order-No.	€	Order-No.	€	
150	60	310	35	4	10	0001-110 114			0181-110 924			

Broomhandle

wood

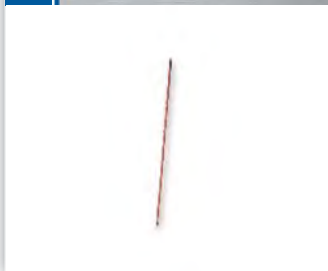

mm			pcs.	wood	RRP		wood pine	RRP	
Ø	L	Order-No.		€	Order-No.	€	Order-No.	€	
28	1400	0003-999 027	5						
24	1300		5			0003-999 026 *			

* with screw

Hand brushes

Paint Brushes
plastic handle



SPECIAL

mm				light bristle	RRP				
T	B	Thickness	pcs.	Order-No.	€	Order-No.	€	Order-No.	€
40	20	9	12	0003-086 102					
40	30	9	12	0003-086 103					
40	40	9	12	0003-086 104					
43	50	9	12	0003-086 105					



Paint Brushes
plastic handle



SPECIAL

mm				light bristle	RRP					
T	B	Thickness	inch	pcs.	Order-No.	€	Order-No.	€	Order-No.	€
42	38		1 1/2"	12	1003-086 438					
42	50,8		2"	12	1003-086 450					

Heating element brush.



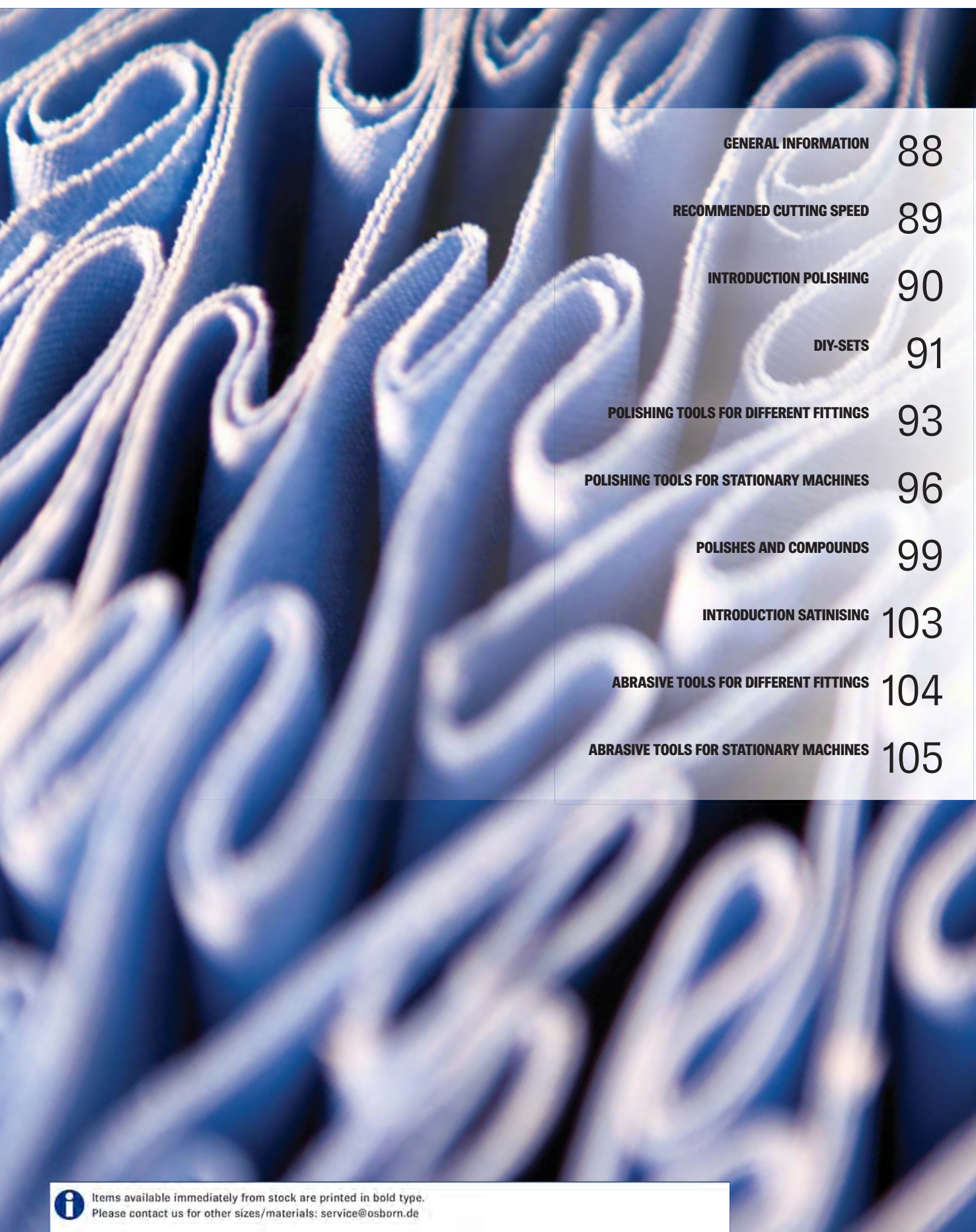

GENERAL INFORMATION	88
RECOMMENDED CUTTING SPEED	89
INTRODUCTION POLISHING	90
DIY-SETS	91
POLISHING TOOLS FOR DIFFERENT FITTINGS	93
POLISHING TOOLS FOR STATIONARY MACHINES	96
POLISHES AND COMPOUNDS	99
INTRODUCTION SATINISING	103
ABRASIVE TOOLS FOR DIFFERENT FITTINGS	104
ABRASIVE TOOLS FOR STATIONARY MACHINES	105



Polishing/Satinising

Introduction & technical information

PRODUCT INTRODUCTION

POLISHING/SATINISING

Fine surface finishing for every application

Professional surface finishing encompasses a complex and broad spectrum of different mechanical finishing processes in which polishing and satinising play a key role.

As a specialist in surface fine machining, Osborn offers a large selection of high-performance tools for all applications associated with polishing and satinising. We have organised our polishing and satinising products in such a way to suit the type of machine used.

The three key techniques for achieving the perfect surface finish:

There are 3 techniques for producing the desired surface finish.

1. Polishing (power tools)

Polishing is intended to **create perfect high-gloss surfaces** and can be performed using a variety of power tools.

Generally, 3 steps are needed:

- **Cutting**
- **Polishing**
- **Colouring**



We recommend a combination of different quality polishing cloths and polishing compounds. Please note that polishing compound is a must for polishing.

2. Polishes & compounds

Our compounds supplement our range of surface-polishing tools.

The **polishing compounds can be used for manual or machine polishing** and cover the entire range of surface finishing, from grinding and brushing to cutting and colouring.



Steel, stainless steel, non-ferrous metals, wood, paint and many other surfaces can be finished when combined with the appropriate polishing tool.

3. Satinising (power tools)

The starting point is a high-gloss surface. Through satinising, the high-gloss surface will receive a **matt look. The finishing result may vary (coarse, medium, fine).**

A satinised finish can be created using wet and dry techniques.



Satinising is usually a one-stage process.

No polishing compound is needed for satinising because the abrasive particles are already embedded in the base material of the satinising tool.

CUTTING SPEED

Cutting speed depending on rounds per minute and diameter

Cutting speed	U/min	Ø mm									m/sec
		100	150	200	250	300	350	400	450	500	
300											m/sec
300											m/sec
400											m/sec
500											m/sec
600							11	12	14	15	m/sec
800				10	12	14	16	18	20		m/sec
1400			14	18	22	25	29	33	36		m/sec
1600		12	16	20	25	29	33	37	41		m/sec
1800		14	18	23	28	33	37	42	47		m/sec
2000	10	15	21	26	31	36	41	47	52		m/sec
2200	12	17	23	28	34	40	46	51	57		m/sec
2400	13	19	25	31	37	44	50	56			m/sec
2600	14	20	27	34	40	47	53				m/sec
2800	15	22	29	36	43	51	58				m/sec
3000	16	23	31	39	47	55	63				m/sec

Economic cutting speeds (average values):

Usage	Cutting speed
Grinding	ca. 30 m/sec
Satinising	ca. 20 m/sec
Cutting	ca. 25–30 m/sec
Polishing of metal	ca. 30–36 m/sec ± 15 %
Polishing of metal (strong contours)	ca. 20 m/sec ± 10 %
Polishing of plastic	ca. 15 m/sec ± 10 %

The higher the number of revolutions per minute (RPM), the harder and less flexible the trim.

Polishing/Satinising

Introduction polishing

PERFECT POLISHING

Watch the video on YouTube:
www.youtube.com/osbornesolutions



Maximum 3 steps for perfect high-gloss surfaces:

1. Cutting follows surface grinding and removes material. For this reason, cutting is not suitable for soft metals. Working with a sisal cloth ring smooths out unevenness, removes striae and scratches, and prepares rough and uncoated surfaces for polishing.

2. High-quality polishing removes traces of cutting and further smooths the surface. The best results can be achieved using our specially developed NOTIFLEX® polishing cloth (outstanding results without unattractive bias stitching where reduced amounts of compound are used). Numerous high quality non-fraying cloth polishing buffs with extended service life are available.

3. Colouring calls for minimal pressure and short finishing times. Again various polishing buffs are available.

Which combination for which result?

The following summary will help you find the best combination of polishing compound and polishing tools needed for each step in finishing each material.

▶ The short version can be found in the info area for each product.

Key to the materials below

- 1 = Sisal cloth
- 2 = Notiflex (NTF) 914
- 3 = Notiflex (NTF) 925
- 4 = Compound, white
- 5 = Compound, brown
- 6 = Compound, blue
- 7 = Felt 2-stage
- 8 = Cloth 101
- 9 = Cloth 290
- 10 = Felt 3-stage

		Steel					Stainless steel					Aluminium					Brass					Copper				
		1	2	3	4	5	1	2	3	4	5	1	2	3	4	5	1	2	3	4	5	1	2	3	4	5
3 STEPS	Polishing as a 3-step process System using top-quality, patented Notiflex mat without bias stitching. Suitable for all machines, diameters and bores.																									
	1. Cutting For removing defects and scratches, belt sanding > 280 grit or sisal lines.		1 o. 10	1 o. 10	1 o. 10	starting with step 2																				
		4	4	5																						
2. Polishing Removing traces of cutting and blending the surface. Important for achieving a flat, high-gloss surface in the next step.		2 o. 10	2 o. 10	2 o. 10	2 o. 10	2 o. 10																				
	4	4	5	5	5																					
3. Colouring For high-gloss surfaces.		3 o. 10	3 o. 10	3 o. 10	3 o. 10	3 o. 10																				
	6	6	6	6	6																					
2 STEPS	Polishing as a 2-step process Suitable for applications where no cutting is needed. Please note: there is a special summary of polishing buffs and compounds for the 2-step method using a satiniser.																									
	1. Polishing Level the surface. Important for achieving a flat, high-gloss surface in the next step.		7	7	7	7	7																			
		4	4	5	5	5																				
2. Colouring For high-gloss surfaces.		8	8	8	8	8																				
	6	6	6	6	6																					
1 STEP	Polishing as a 1-step process																									
	1. Polishing and finishing For low-gloss effects (not high gloss)		9	9	9	9	9																			
	4	4	5	5	5																					

Polishing/Satinising DIY-Sets

Polishing Kit DIY



The 6-piece kit contains everything you need for the 2-stage polishing process: polishing mop, felt, drive arbor, compound for polishing and colouring.



USAGE

- Felt, 2-stage, 7
 - Felt, 3-stage, 10
 - Cloth, 290, 9
 - Cloth 101, 8
 - Sisal cloth, 1
 - NTF914, 2
 - NTF925, 3
2. Polishing
3. Colouring

mm	Ø	B	rpm	pcs.	Polishing kit 2-stage	RRP
					Order-No.	€
85/80	10		4000	5	120360000	

TRIM AND MATERIAL

Product available with

	Steel	Stainless steel	Aluminium	Brass	Copper
Polishing	7 4	7 4	7 4	7 4	7 4
Colouring	8 6	8 6	8 6	8 6	8 6

Contents	pcs.
felt, 2-stage	1
101 buffs	1
compound: white, brown, blue	1
tampered shank	1



Polishing Kit professional



The 10-piece kit contains everything you need for the 3-stage polishing process: Polishing buffs, drive arbor, compound for cutting, polishing and colouring.



USAGE

- Felt, 2-stage, 7
 - Felt, 3-stage, 10
 - Cloth, 290, 9
 - Cloth 101, 8
 - Sisal cloth, 1
 - NTF914, 2
 - NTF925, 3
1. Cutting
2. Polishing
3. Colouring

mm	Ø	B	rpm	pcs.	Polishing kit 3-stage	RRP
					Order-No.	€
100	10		4000	6	860360010	

TRIM AND MATERIAL

Product available with

	Steel	Stainless steel	Aluminium	Brass	Copper
Cutting	1 4	1 4	1 4	starting with step polishing	
Polishing	2 4	2 4	2 4	2 4	2 4
Colouring	3 6	3 6	3 6	3 6	3 6

Contents	pcs.
sisal cloth	2
NTF914	2
NTF925	2
compound: white, brown, blue	1
tampered shank	1



POLISHING /
SATINISING

Satinising Kit professional



The 4-part kit contains three satinising buffs (coarse, medium, fine) and a drive arbor.



USAGE

- Satinising
 - Deoxidising
 - Light grinding
 - Light deburring
 - Blending
 - Fine grinding
- coarse
- medium
- fine
- superfine

mm	Ø	B	rpm	pcs.	Satinising Kit	RRP
					Order-No.	€
100	10		4000	6	860360004	

TRIM AND MATERIAL

Product available with

	Steel	Stainless steel	Aluminium	Brass	Copper
coarse					
medium					
fine					

Contents	pcs.
coarse non woven	1
medium non woven	1
fine non woven	1
tampered shank	1



Polishing/Satinising DIY-Sets



	Acrylic Polishing Kit	RRP
à	Order-No.	€
10	1203600001	



The 4-part kit contains Dur Plast polish, sandpaper, sponge and polishing cloth.



SANDING.



APPLYING.



RUBBING.

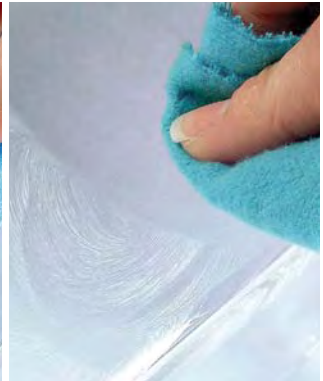

POLISHING.



	Metal Polishing Kit	RRP
à	Order-No.	€
10	1203600002	



The 3-part kit contains Metal polish polish, sponge and polishing cloth.

Polishing/Satinising

Polishing tools for different fittings

Polishing Buffs

cloth or fleece



Material is fixed in a toothed metal ring. The polishing buff is clamped using conical spring washers.



USAGE

1. Cutting	<input type="checkbox"/>	<input type="checkbox"/>	<input type="checkbox"/>	<input type="checkbox"/>	<input type="checkbox"/>	<input type="checkbox"/>	<input type="checkbox"/>	<input type="checkbox"/>	<input type="checkbox"/>
2. Polishing	<input type="checkbox"/>	<input type="checkbox"/>	<input type="checkbox"/>	<input type="checkbox"/>	<input type="checkbox"/>	<input type="checkbox"/>	<input type="checkbox"/>	<input type="checkbox"/>	<input type="checkbox"/>
3. Colouring	<input type="checkbox"/>	<input type="checkbox"/>	<input type="checkbox"/>	<input type="checkbox"/>	<input type="checkbox"/>	<input type="checkbox"/>	<input type="checkbox"/>	<input type="checkbox"/>	<input type="checkbox"/>

Felt, 2-stage, 7
 Felt, 3-stage, 10
 Cloth 280, 9
 Cloth 101, 8
 Sisal cloth, 1
 NTF914, 2
 NTF925, 3

TRIM AND MATERIAL

Product available with

	Steel	Stainless steel	Aluminium	Brass	Copper
Cutting	1 4	1 4	1 6	starting with step polishing	
Polishing	2 4	2 4	2 6	2 6	2 6
Colouring	3 6	3 6	3 6	3 6	3 6

mm	mm	mm	rpm	pcs.	1 sisal cloth	RRP	2 NTF914	RRP	3 NTF925	RRP
Ø	A	B			Order-No.	€	Order-No.	€	Order-No.	€
100	17	10	4000	10	8203100944					
100	15	10	4000	5*			8203100914			
100	10	10	4000	5*					8203100925	
150	17	14	3000	10	8203150944					
150	15	14	3000	5*			8203150914			
150	10	14	3000	5*					8203150925	
200	17	14	3000	10	8211201944					
200	15	14	3000	5*			8203200914			
200	10	14	3000	5*					8203200925	

* Here, 5 pcs. correspond to 10 buffs, because our Notiflex buffs are supplied in 2-buff sets.

Tapered Shanks



Conical shaft for angle polisher for tensioning polishing and satinising buffs with bores from 14 mm to 150 mm dia.



mm	mm	mm	rpm	pcs.	Order-No.	RRP
A	G					€
15-30	M14	8		8	1203300003	
15-50	M14	8		8	1213300003	

Tapered Shanks



Tapered shank for power drill or flexible shaft for clamping polishing and satinising buffs with bores from 10 mm to 100 mm dia.



mm	mm	mm	rpm	pcs.	Order-No.	RRP
A	S					€
10-35	6	4		4	8103800224	

POLISHING / SATINISING

Polishing Buffs

cloth or fleece



Material is fixed in a toothed metal ring. The polishing buff is clamped using conical spring washers.



USAGE

1. Cutting	<input type="checkbox"/>	<input type="checkbox"/>	<input type="checkbox"/>	<input type="checkbox"/>	<input type="checkbox"/>	<input type="checkbox"/>	<input type="checkbox"/>	<input type="checkbox"/>	<input type="checkbox"/>
2. Polishing	<input type="checkbox"/>	<input type="checkbox"/>	<input type="checkbox"/>	<input type="checkbox"/>	<input type="checkbox"/>	<input type="checkbox"/>	<input type="checkbox"/>	<input type="checkbox"/>	<input type="checkbox"/>
3. Colouring	<input type="checkbox"/>	<input type="checkbox"/>	<input type="checkbox"/>	<input type="checkbox"/>	<input type="checkbox"/>	<input type="checkbox"/>	<input type="checkbox"/>	<input type="checkbox"/>	<input type="checkbox"/>

Felt, 2-stage, 7
 Felt, 3-stage, 10
 Cloth 280, 9
 Cloth 101, 8
 Sisal cloth, 1
 NTF914, 2
 NTF925, 3

TRIM AND MATERIAL

Product available with

	Steel	Stainless steel	Aluminium	Brass	Copper
Cutting	1 4	1 4	1 6	starting with step polishing	
Polishing	2 4	2 4	2 6	2 6	2 6
Colouring	3 6	3 6	3 6	3 6	3 6

mm	mm	mm	rpm	pcs.	1 sisal cloth	RRP	2 NTF914	RRP	3 NTF925	RRP
Ø	A	B			Order-No.	€	Order-No.	€	Order-No.	€
100	17	19/6	4000	10	2103100944					
100	15	19/6	4000	5*			2103100914			
100	10	19/6	4000	5*					2103100925	

* Here, 5 pcs. correspond to 10 buffs, because our Notiflex buffs are supplied in 2-buff sets.

Polishing/Satinising

Polishing tools for different fittings

Polishing Buffs
cloth



The polishing buff is clamped using conical spring washers.

USAGE



Felt, 2-stage, 7
 Felt, 3-stage, 10
 Cloth 280, 9
 Cloth 101, 8
 Suede, 1
 NTF925, 2
 NTF925, 3

1. Cutting
 2. Polishing
 3. Colouring

TRIM AND MATERIAL

Product available with

	Steel	Stainless steel	Aluminium	Brass	Copper
Polishing	9 4	9 4	9 4	9 4	9 4
Colouring	6 8	6 8	6 8	6 8	6 8

mm	mm	mm	mm	rpm	pcs.	9 cloth 290	RRP	8 cloth 101	RRP
Ø	A	B	S			Order-No.	€	Order-No.	€
100	17	19/6		4000	10	1903100290		1903100101	

Polishing Buffs
cloth or fleece



USAGE



Felt, 2-stage, 7
 Felt, 3-stage, 10
 Cloth 280, 9
 Cloth 101, 8
 Suede, 1
 NTF925, 2
 NTF925, 3

1. Cutting
 2. Polishing
 3. Colouring

TRIM AND MATERIAL

Product available with

	Steel	Stainless steel	Aluminium	Brass	Copper
Polishing	7 4	7 4	7 4	7 4	7 4
Colouring	6 8	6 8	6 8	6 8	6 8

mm	mm	mm	mm	rpm	pcs.	7 fleece 2 stuffig	RRP	8 cloth 101	RRP
Ø	A	B	S			Order-No.	€	Order-No.	€
85	15	10		4000	10	1503015085			
80	10	10		4000	10			2103080101	
80	10	10	6	4000	12			1903080101	
100	10	10		4000	10			2103100101	

Polishing Buffs
cloth or fleece



Material is fixed in a toothed metal ring.

USAGE



Felt, 2-stage, 7
 Felt, 3-stage, 10
 Cloth 280, 9
 Cloth 101, 8
 Suede, 1
 NTF925, 2
 NTF925, 3

1. Cutting
 2. Polishing
 3. Colouring

TRIM AND MATERIAL

Product available with

	Steel	Stainless steel	Aluminium	Brass	Copper
Polishing and finish	9 6	9 6	9 6	9 6	9 6

mm	mm	mm	mm	rpm	pcs.	9-polishing cloth 290	RRP
Ø	A	B	S			Order-No.	€
80	10	10		4000	10	2103080290	
80	10	10	6	4000	12	1903080290	
100	10	10		4000	10	2103100290	

Polishing/Satinising

Polishing tools for different steel fittings



USAGE

battery friendly

1. Cutting Felt, 2-stage, 7
 2. Polishing Felt, 3-stage, 10
 3. Colouring Cloth 290, 9
 Cloth 101, 8
 Sisal cloth, 1
 NTF914, 2
 NTF925, 3

TRIM AND MATERIAL

Product available with

	Steel	Stainless steel	Aluminium	Brass	Copper
Cutting	1 4	1 4	1 4		

starting with step polishing

mm	G	rpm	pcs.	1 sisal cloth	RRP
Ø	G	rpm	pcs.	Order-No.	€
100	M14	9000	7	L940030842	



For Cutting, removing defects and scratches. Developed for usage on cordless power tools: Low weight, precise working without vibrations. Due to the weight reduction the battery life can be prolonged between 20–25%. You can work longer and reduce the charging cycles of your power tool.



USAGE

battery friendly

1. Cutting Felt, 2-stage, 7
 2. Polishing Felt, 3-stage, 10
 3. Colouring Cloth 290, 9
 Cloth 101, 8
 Sisal cloth, 1
 NTF914, 2
 NTF925, 3

TRIM AND MATERIAL

Product available with

	Steel	Stainless steel	Aluminium	Brass	Copper
Colouring	6	6	6	6	6

mm	G	rpm	pcs.	3 NTF925	RRP
Ø	G	rpm	pcs.	Order-No.	€
100	M14	9.000	7	L911000436	



For Colouring (high-gloss surface). Developed for usage on cordless power tools: Low weight, precise working without vibrations. Due to the weight reduction the battery life can be prolonged between 20–25%. You can work longer and reduce the charging cycles of your power tool.

More information and further accessories for cordless power tools see pages 36–38 and 104.

POLISHING / SATINISING

Polishing/Satinising

Polishing tools for stationary machines



Wave Buffs are corrugated waves of cotton cloth or sisal-cloth fixed around a metal clinch ring. This uniform construction ensures a long service life, high polishing action and a cool air effect. Applications: in combination with Osborn compounds, flat parts, pots & pans can be polished and finished, this product is also suitable for removing dust after sanding wood. The construction prevents the working surface from becoming too hot, ideal conditions for a perfect finish. Wave buffs are the chosen product when machine oscillation is not available.

Cutting sisal/cloth

mm		○		📦		sisal/cloth		RRP	
Ø	Layers	B	Treatment	pcs.	Order-No.	€		€	
300	3	80		5	L043310093				
350	3	130	H2	5	L043310047				
350	3	130	H5A	5	L043310025				
360	3	130		5	L043310189				

Cutting cotton

mm		○		📦		medium		RRP		medium hard		RRP	
Ø	Layers	B	Treatment	pcs.	Order-No.	€	Order-No.	€	Order-No.	€	Order-No.	€	
300	16	80		5	L013300214				L013300348				
350	16	130		5									



Cloth Type	Properties
TT	hard orange
DF590	stiff green
308	medium hard
290	medium
215	medium soft
101A	soft
M05	molton



These general purpose buffs are manufactured with irregular folds clasped in a metal clinch ring. This is our standard, most cost effective buff for nearly all polishing and finishing applications. Buffs can be mounted together on a shaft to achieve any required width. Some trim materials can be treated for a stiffer buff and extended service life.

Cutting

mm		○		📦		sisal/cloth		RRP		medium hard		UVP		hard orange		RRP	
Ø	Layers	B	Treatment	pcs.	Order-No.	€	Order-No.	€	Order-No.	€	Order-No.	€	Order-No.	€	Order-No.	€	
400	16	130		5	L000000962												
400	16	130	HSE	5	L043090792												
400	16	130		5					L013030989				L013033828				

Polishing

mm		○		📦		medium		RRP	
Ø	Layers	B	Treatment	pcs.	Order-No.	€	Order-No.	€	
400	16	130		5	L013030179				

Colouring

mm		○		📦		molton		RRP		soft		RRP	
Ø	Layers	B	Treatment	pcs.	Order-No.	€	Order-No.	€	Order-No.	€	Order-No.	€	
400	16	130		5	L013030901				L000006338				



Cloth Type	Properties
TT	hard orange
DF590	stiff green
308	medium hard
290	medium
215	medium soft
101A	soft
M05	molton

Polishing/Satinising

Polishing tools for stationary machines

Pleated Buffs

cloth



Cloth is folded with regular pleats, arranged and fixed around a cardboard core. Pleated Buffs are used for polishing and finishing particularly complex parts. These buffs combine a cool air effect with great resilience. To process a wider part, several buffs can be ganged together. The uniform folds guarantee excellent results, with high compound retention and a long service life. Different trim quality is available depending on whether the process is polishing or colouring.

Cutting

mm		⊙			medium hard	RRP	stiff green	RRP	hard orange	RRP
Ø	Layers	B	Treatment	pcs.	Order-No.	€	Order-No.	€	Order-No.	€
300	16	80		5	L113010745		L113010744		L113010743	
350	16	130		5	L012022230		L012021731		L113010746	

Polishing

mm		⊙			medium soft	RRP	medium	RRP
Ø	Layers	B	Treatment	pcs.	Order-No.	€	Order-No.	€
300	16	80		5	L013010167		L012022605	
350	16	130		5	L012021660		L012022573	

Colouring

mm		⊙			Molton	RRP
Ø	Layers	B	Treatment	pcs.	Order-No.	€
300	16	80		5	L012021292	
350	16	130		5	L012022404	



Cloth Type	Properties
TT	hard orange
DF590	stiff green
308	medium hard
290	medium
215	medium soft
101A	soft
M05	molton

Airflow Buffs

sisal



Open structured biased sisal web is clasped in a metal clinch ring. Close stitching results in a very hard buff creating minimum dust when in operation. Sisal airflow buffs are the most cost effective solution for all cutting operations whether processing: pan lids, stainless steel, aluminum or non-ferrous metal surfaces, builder's hardware, car parts or household appliances.

mm		⊙			SiFN	RRP
Ø	Layers	B	Treatment	pcs.	Order-No.	€
350	10	130		5	L023060786	



Polishing/Satinising

Polishing tools for stationary machines



mm		⊙		📦	48	RRP
∅	Layers	B	Treatment	pcs.	Order-No.	€
300	4	80	H5A	5	L033440041	
300	4	80		5	L033440201	
400	4	130	V66	5	L033440645	
400	4	130		5	L000020899	



Sisal cord strands are arranged and held by the metal clinch ring. This is an extremely flexible product, remaining cool in operation and ideal for the cutting operation on highly contoured parts. Service life and stiffness can be extended by adding special treatments.



mm		📦	K80 A2T	RRP
∅	Reduced to	pcs.	Order-No.	€
80	20	2	L800000126	
80	22	2	L000044060	
80	25	2	L800000008	
80	35	2	L800000046	
80	45	2	L800000048	
80	50	2	L800000084	
80	2" (50,8)	2	L800000119	
130	22	2	4403022130	
130	30	2	L800000066	
130	35	2	L000002066	
130	60	2	L800000029	
130	80	2	L800000055	

Airflows, pleated buffs and wave buffs are most economically manufactured on a metal clinch ring. The inside diameter of the clinch ring may fit precisely on the machine shaft, more commonly the inside diameter can be reduced to the correct bore size with reusable metal centre-plates.

Polishing/Satinising Polishes and compounds



The right compound for your finishing step

Polishing compounds are essential for all polishing jobs because they contain the necessary ingredients to achieve a particular surface finish.

It is also important to select the correct polishing compound for the desired surface finish.



Important note:

No polishing compound is needed for satinising because the abrasive particles are already embedded in the base material of the satinising tool.

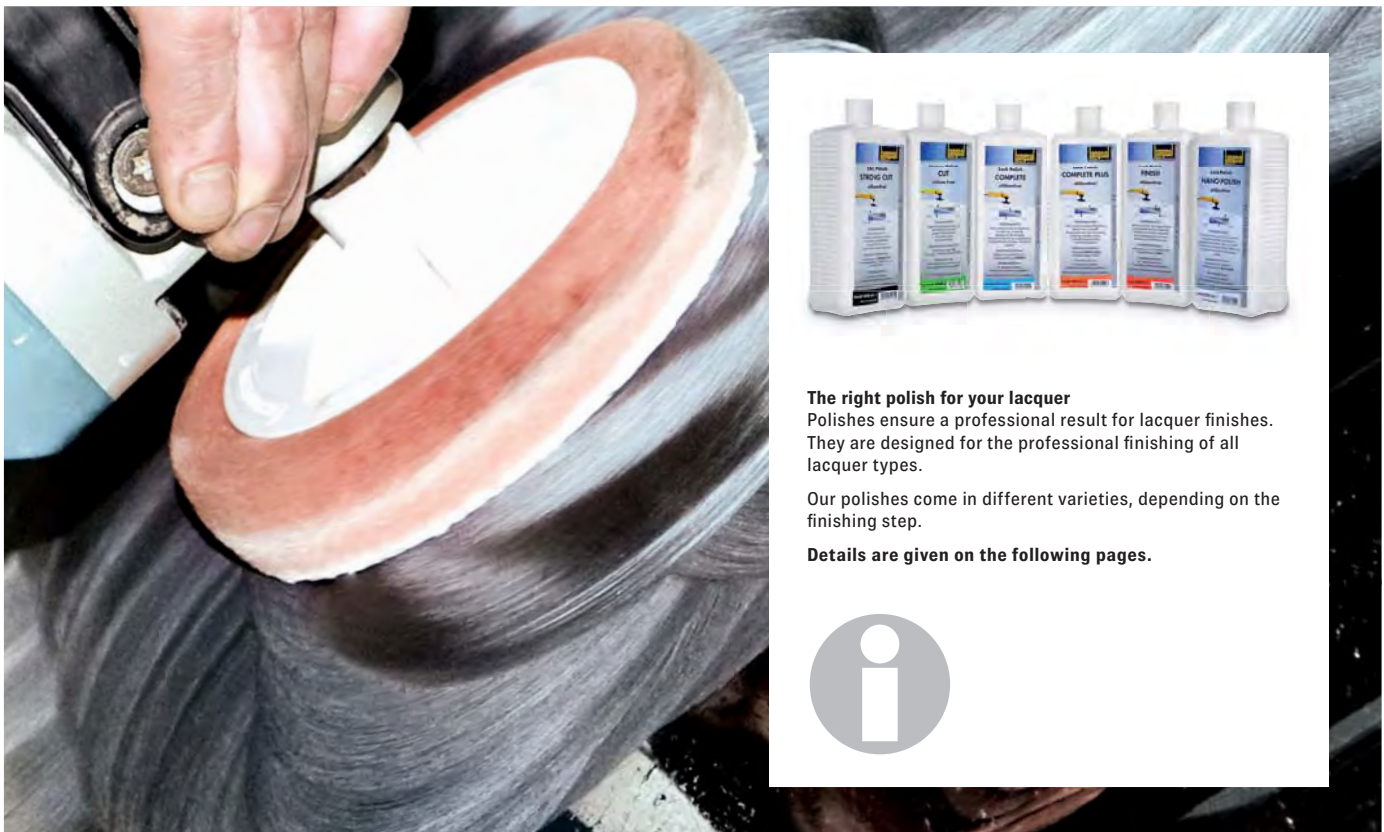

The right polish for your lacquer

Polishes ensure a professional result for lacquer finishes. They are designed for the professional finishing of all lacquer types.

Our polishes come in different varieties, depending on the finishing step.

Details are given on the following pages.



Polishing/Satinising Polishes and compounds



Important user information

Polishes and compounds – the key to a perfect polishing result



What to look for when selecting the right polish:

1. General user information

Our polishes are intended for the professional finishing of all lacquer types. Different compounds are available for different finishing steps. Details are given in the figures below.

2. Polish types and applications

Strong Cut

High-efficiency abrasive compound for **scratches and damage** that can still be repaired. For the **second step**, we recommend **Nano-Polish**.

Cut

Fine abrasive compound for all **wear/ weathering marks in older** paints. For a deep gloss, we recommend using **Nano-Polish in the second step**.

Complete

Fine abrasive compound to remove all **wear/ weathering marks** in all kinds of paint. For dark paint, we recommend using **Finish in the second step**.

Complete Plus

Especially for small scratches and for reviving surfaces. **For dark lacquer we recommend Finish as second step.**

Finish

Ideal for the **hologram-free** removal of tiny **scratches and films** on conventional and fresh paints. Brings a deep and brilliant gloss to dark lacquer.

Nano-Polish

Especially suitable for the new generation of scratch-resistant lacquer. For removing tiny **scratches, holograms and films** to give a deep and brilliant gloss.



3. Detailed information



Rotational speed

rotating (n=rpm)	1500–2000	1500–2000	1500–2000	1500–2000	1500–2000	1500–2000
eccentric (n=rpm)	2000–10000	2000–10000	2000–10000	2000–10000	2000–10000	2000–10000

Finishing flaws

Orange peel	✓	✓	✓	✓	✓	✓
Holograms	–	–	–	–	✓	✓
Scratches	✓	✓	✓	✓	✓	✓
Weathering	–	✓	✓	✓	–	–

For OEMs

Paint runs	–	–	–	✓	✓	✓
Dirt inclusions	–	–	–	✓	✓	✓

Use/Lacquer type

Conventional type	1.500	2.000	2.000–3.000	2.000–3.000	3.000–4.000	2.500–4.000	rpm
Scratch resistant paint	–	2.000	2.500	2.500	3.500–4.000	3.000–4.000	rpm
Fresh paint	1.500	2.000	2.000–3.000	2.000–3.000	3.000–4.000	2.500–4.000	rpm
With Pad*	orange	orange/blue	orange/blue	orange/blue	black	black	
Properties	hard	medium	medium	medium	soft	soft	
With lambskin*	✓	✓	✓	✓	–	–	

Lacquer type

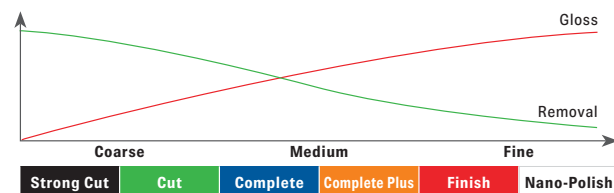

Strong Cut		RRP	Cut		RRP	Complete		RRP	Complete Plus		RRP	Finish		RRP	Nano-Polish		RRP
ml	pcs.	Order-No.	€	Order-No.	€	Order-No.	€	Order-No.	€	Order-No.	€	Order-No.	€	Order-No.	€		
1000	8	L699940320		L699740250		L699940250		L699940260		L699740340		L699940340					

* Pads and lambskin can be obtained from good accessory dealers.



Important:
We recommend first trying in an inconspicuous spot.

Polishing/Satinising Polishes and compounds

Polishes liquid



		Dur Plast		RRP
ml	pcs.	Order-No.	€	
50	10	2103002101		
1000	6	L669002101		

For non-grained hard plastics, plexiglass or macrolon, polyester, acryl. Do not use on coated visors.

		Metal Polish		RRP
ml	pcs.	Order-No.	€	
50	10	2103002102		
1000	6	L669002102		

For chrome, aluminum, silver, stainless steel, brass, copper, tin and hard plastic materials.

Polishing Compounds solid



USAGE

	Steel	Stainless steel	Aluminium	Brass	Copper
white (cutting)	■	■	■	■	■
white (polishing)	■	■	■	■	■
brown (cutting)	■	■	■	■	■
brown (polishing)	■	■	■	■	■
blue (colouring)	■	■	■	■	■

		4 white		RRP	5 brown		RRP	6 blue		RRP
gr.	pcs.	Order-No.	€		Order-No.	€		Order-No.	€	
110	15	2103005333			2103007012			2103000461		

For our comprehensive standard compounds assortment please see next page.

Polishing/Satinising Polishes and compounds

OSBORN CLASSIC® COMPOUND RANGE



Osborn Classic® Compounds are top selling products taken from the former Unipol® and Langsol® ranges. The 14 compounds achieve excellent results whether brushing, polishing, colouring or superfinishing on aluminium, stainless steel, non-ferrous or plastic. They can be used together with all buffs in the Osborn range in a one-step or multi-step process.

Process	Colour	Type	Name	Description	pcs.	Order-No.	RRP €	Apply on				Matrix		
								Aluminium	Stainless	Non-ferrous	Plastics	fat 1=low, 10=high	cut 1=low, 10=high	gloss 1=low, 10=high
Brushing	grey	39.038.1	B1000	Greasy, abrasive general brushing compound for deburring and satin finishing	1	L779840010		X	X	X		8	9	3
Polishing	brown	7012	P1000	Cutting compound for brass, high cut and medium gloss	1	L779007012				X	X	4	8	4
	brown	2.292	P2000	All-round cutting compound for lead-free brass, zinc; achieves glossy and line-free surface	1	L779132001		X		X		3	7	5
	white	5333	P3000	All-purpose cutting compound for stainless steel, use with sisal buffs	1	L779005333			X			6	8	4
	light green	2043 JF	P4000	All-purpose cutting compound for stainless steel, use with cotton buffs	1	L779930401			X	X		6	7	4
	blue	466	P5000	Cut & colour compound for aluminium, stainless brass and zinc; one-step polishing process	1	L779000466		X		X		4	6	6
	orange	Edelgelb	P6000	Cut & colour compound for aluminium, with high fat content for line-free surface, easy degreasing	1	L779840130		X				4	4	6
	dark pink	433	P7000	Cut & colour compound for aluminium, stainless brass and zinc; higher gloss than P5000	1	L779000433		X	X	X		3	6	7
Colouring	white	665	P8000	All-round polishing compound for lacquers and plastics	1	L779001385					X	3	4	6
	beige	9216	C1000	Colouring compound for all lacquers and plastics when higher gloss required	1	L779920160					X	2	3	7
	blue	462	C2000	All-round colouring compound, ideal for stainless steel	1	L779000462			X			2	3	8
Super finish	light pink	1003A	C3000	All-round colouring compound, ideal for aluminium, zinc and stainless steel	1	L779191001		X	X	X		3	3	8
	yellow	SA 175	F1000	High end colouring compound achieves a dark shine	1	L779000175			X	X	X	2	2	9
	light orange	Gold easy	F2000	Top colouring compound for a deep line-free gloss	1	L779009510			X	X		1	1	10

1 piece = approx. 1.000–1.200 g

PERFECT SATINISING

Hier youtube-Video ansehen.
www.youtube.com/osbornolutions



Satinising is a one-stage system for creating flat surfaces. The main considerations when selecting the satinising buff are what the original high-gloss surface should look like after the satinising process.

There are three possible finish grades when satinising a surface.

Coarse brush stroke



Medium brush stroke



Fine brush stroke



Important note

Non-woven abrasive tools are used without polishing compound because the abrasive particles are already embedded in the base material of the satiniser.

These tools made of matted material containing abrasive particles are characterised by an open and flexible structure. They are self-sharpening and can be used in wet and dry applications.

Because they can also be used with hand-held tools, they are ideal for a wide range of applications, from satinising to deoxydising to superfine grinding.

Our non-woven abrasive tools are available in different grades and sizes, depending on their purpose.



Finding the right tool

Please check your product choice using the information in the info heading. This will tell you the machine for each product and its suitability, as well as providing a summary of the available carrier material grades (grits) suitable for the material being finished.

 USAGE					
		coarse	medium	fine	superfine
Satinising	<input type="checkbox"/>	<input checked="" type="checkbox"/>	<input checked="" type="checkbox"/>	<input type="checkbox"/>	<input type="checkbox"/>
Desoxydising	<input checked="" type="checkbox"/>	<input type="checkbox"/>	<input type="checkbox"/>	<input type="checkbox"/>	<input type="checkbox"/>
Light grinding	<input type="checkbox"/>	<input checked="" type="checkbox"/>	<input checked="" type="checkbox"/>	<input type="checkbox"/>	<input type="checkbox"/>
Light deburring	<input checked="" type="checkbox"/>	<input type="checkbox"/>	<input type="checkbox"/>	<input type="checkbox"/>	<input type="checkbox"/>
Blending	<input type="checkbox"/>	<input type="checkbox"/>	<input type="checkbox"/>	<input checked="" type="checkbox"/>	<input type="checkbox"/>
Fine Grinding	<input type="checkbox"/>	<input type="checkbox"/>	<input type="checkbox"/>	<input type="checkbox"/>	<input checked="" type="checkbox"/>

TRIM AND MATERIAL		Steel	Stainless steel	Aluminium	Brass	Copper
Product available with						
coarse	→	<input type="checkbox"/>	<input type="checkbox"/>	<input type="checkbox"/>	<input type="checkbox"/>	<input type="checkbox"/>
medium	→	<input type="checkbox"/>	<input type="checkbox"/>	<input type="checkbox"/>	<input type="checkbox"/>	<input type="checkbox"/>
fine	→	<input type="checkbox"/>	<input type="checkbox"/>	<input type="checkbox"/>	<input type="checkbox"/>	<input type="checkbox"/>
superfine	→	<input type="checkbox"/>	<input type="checkbox"/>	<input type="checkbox"/>	<input type="checkbox"/>	<input type="checkbox"/>

Polishing/Satinising

Abrasive tools for different fittings



Material is fixed in a toothed metal ring. The satiniser buff is clamped using conical spring washers.

USAGE

	coarse	<input type="checkbox"/>
	medium	<input type="checkbox"/>
	fine	<input type="checkbox"/>
	superfine	<input type="checkbox"/>
Satinising	<input type="checkbox"/>	<input checked="" type="checkbox"/>
Deoxidising	<input type="checkbox"/>	<input type="checkbox"/>
Light grinding	<input type="checkbox"/>	<input type="checkbox"/>
Light deburring	<input type="checkbox"/>	<input type="checkbox"/>
Blending	<input type="checkbox"/>	<input type="checkbox"/>
Fine grinding	<input type="checkbox"/>	<input type="checkbox"/>

TRIM AND MATERIAL

Product available with

coarse	→	<input type="checkbox"/>	Steel
medium	→	<input type="checkbox"/>	Stainless steel
fine	→	<input type="checkbox"/>	Aluminium
		<input type="checkbox"/>	Brass
		<input type="checkbox"/>	Copper

mm	mm	mm	rpm	pcs.	coarse	RRP	medium	RRP	fine	RRP
Ø	A	B			Order-No.	€	Order-No.	€	Order-No.	€
100	23	10	4000	10	8203100934					
100	30	10	4000	10			8203100936		8203100947	
150	25	14	3000	10	8203150934					
150	30	14	3000	10			8203150936		8203150947	
200	25	14	3000	10	8203200934					
200	30	14	3000	10			8203200936		8203200947	

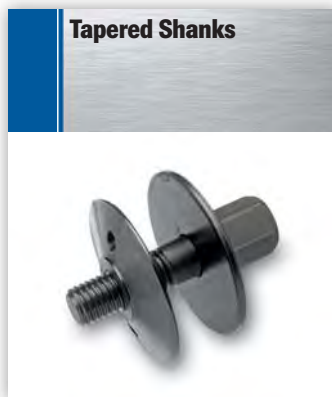

Conical shaft for angle polisher for tensioning polishing and satinising buffs with bores from 14 mm to 150 mm dia.

USAGE

mm	A	G	pcs.	Order-No.	RRP
					€
15-30	M14		8	1203300003	
15-50	M14		8	1213300003	



Tapered shank for power drill or flexible shaft for clamping polishing and satinising buffs with bores from 10 mm to 100 mm dia.

USAGE

mm	mm	pcs.	Order-No.	RRP
A	S			€
10-35	6	4	8103800224	

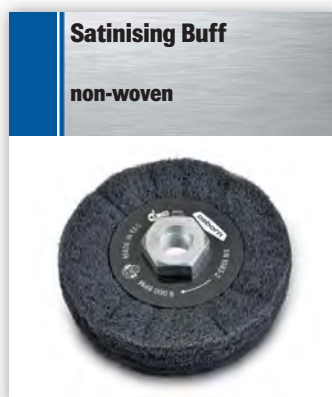

For satinising, desoxydising, light grinding/ deburring, blending and fine grinding. Surface will be have a fine, matt finish. Can be used in wet and dry processes. Don't use polishing compound. Developed for usage on cordless power tools: Low weight, precise working without vibrations. Due to the weight reduction the battery life can be prolonged between 20–25%. You can work longer and reduce the charging cycles of your power tool.

USAGE

	coarse	<input type="checkbox"/>
	medium	<input type="checkbox"/>
	fine	<input type="checkbox"/>
	superfine	<input type="checkbox"/>
Satinising	<input type="checkbox"/>	<input checked="" type="checkbox"/>
Deoxidising	<input type="checkbox"/>	<input type="checkbox"/>
Light grinding	<input type="checkbox"/>	<input type="checkbox"/>
Light deburring	<input type="checkbox"/>	<input type="checkbox"/>
Blending	<input type="checkbox"/>	<input type="checkbox"/>
Fine grinding	<input type="checkbox"/>	<input type="checkbox"/>

TRIM AND MATERIAL

Product available with

coarse	→	<input type="checkbox"/>	Steel
medium	→	<input type="checkbox"/>	Stainless steel
fine	→	<input type="checkbox"/>	Aluminium
		<input type="checkbox"/>	Brass
		<input type="checkbox"/>	Copper

mm	G	rpm	pcs.	fine	RRP
Ø				Order-No.	€
100	M14	9.000	7	L960030577	



i More information on cordless powertool accessories see pages 36–38 and 95.

Polishing/Satinising Abrasive tools for stationary machines

Airflow Buffs

non-woven



mm		⊙	📦	A2 coarse	RRP	A4 medium	RRP	A6 fine	RRP	A7 very fine	RRP
Ø	Layers	B	Treatment	pcs.	Order-No.	Order-No.	Order-No.	Order-No.	Order-No.	Order-No.	Order-No.
300	4	80		5	L063800285	L063800261	L063800259	L063800137	L063800288		
350	4	130		5		L063800214					



A variety of abrasive non-woven materials can also be used in the form of airflows, with layers of material gathered around a metal clinch ring. Best results are obtained at low RPM with minimum buff pressure, this also ensures long life. Applications: all satinising operations, on both manual and automatic machines.

Lipprite Wheel



mm	mm	⊙	🔄	📦	K80 A2T	RRP	K100 A4T	RRP	K180 A6T	RRP	K280 A	RRP
Ø	L	B	rpm	pcs.	Order-No.	€	Order-No.	€	Order-No.	€	Order-No.	€
150	25	1"	3200	1	L81545202E		L50452008E		L81545231E		L81545247E	
200	50	3"	2400	1	L000014507		L068011347		L000042624		L68013206J	

The abrasive flaps are bonded radially to a phenolic tube. The three dimensional open web ensures a „self-cleaning action“ for easy removal of surface contamination or to obtain a decorative finish. Ideal for cleaning profiled or irregular parts, suitable to obtain an aesthetic finish.

Lipprox Wheel



mm	mm	⊙	🔄	📦	aluminium A4T C1H7	RRP	aluminium A6T C1H7	RRP	SIC S6T C2H7	RRP	SIC S7T C2H7	RRP
Ø	L	B	rpm	pcs.	Order-No.	€	Order-No.	€	Order-No.	€	Order-No.	€
150	13	1"	3200	1	L15451408A		L15451431A		L15452433A		L15452448A	
150	25	1"	3200	1	L15451408E		L15451431E		L15452433E		L15452448E	
200	13	3"	2400	1	L50901408A		L50901431A		L68014192A		L50902448A	
200	25	3"	2400	1	L50901408E		L50901431E		L68014192E		L50902448E	

The abrasive web is wound around a phenolic tube and treated, this ensures constant hardness and abrasiveness over the life of the product. Lipprox are perfect for light deburring. Suitable for light deburring and fast achievement technical surface finish. The product is clearly marked with a directional arrow and must rotate in the direction shown.

Polishing/Satinising

Abrasive tools for stationary machines

SLK – Coated Abrasive Flap Wheels

abrasive



Top quality coated abrasive flaps, in a selection of grades mounted around a core. Several defined sizes are available. Recommended for grinding formed parts in preparation for polishing. Applications: grinding steel tubes, grinding pots & pans or iron soles prior to polishing.

mm		⊙	📦	K40	RRP	K60	RRP	K80	RRP	K120	RRP
Ø	A	B	pcs.	Order-No.	€	Order-No.	€	Order-No.	€	Order-No.	€
165	50	54	1	0043160050		0063160050				0123160050	
165	50	54	1					0083160050			

Other dimensions on request.

Rolls

non-woven



Rolls of raw abrasive non-woven material in various grades and widths. Applications include general finishing or cleaning of weld seams.

mm		mm	📦	A4 medium	RRP	A6 fine	RRP	A6 vevry fine	RRP
L	B	pcs.	Order-No.	€	Order-No.	€	Order-No.	€	
10000	115	1	L063330245		L063330127		L063330132		



Please note, satin finishing rollers can be found in the chapter machinebrushes on page 70/71.

Centre-Plates



Airflows, pleated buffs and wave buffs are most economically manufactured on a metal clinch ring. The inside diameter of the clinch ring may fit precisely on the machine shaft, more commonly the inside diameter can be reduced to the correct bore size with reusable metal centre-plates.

mm		📦	K80 A2T	RRP
Ø	Reduced to	pcs.	Order-No.	€
80	20	2	L800000126	
80	22	2	L000044060	
80	25	2	L800000008	
80	35	2	L800000046	
80	45	2	L800000048	
80	50	2	L800000084	
80	2" (50,8)	2	L800000119	
130	22	2	4403022130	
130	30	2	L800000066	
130	35	2	L000002066	
130	60	2	L800000029	
130	80	2	L800000055	

BRUSHES 108

INTERNAL FINISHING 119

ATB 133

NOVOTEC 138

Brushtech Industrial Brushes



Important user information Brushes for stationary machines



To be noted when selecting brushes and using stationary machines:

1. General user information

Brushes for stationary machines are suitable for bench deburrers, double grinders and special deburring machines.

2. Typical brushes for stationary machines



Wheel brushes

Available with knotted and crimped wire, as well as abrasive filaments.

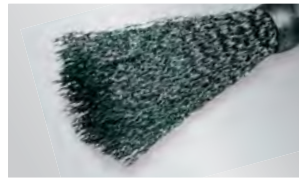

End brushes

Available for brush heads for cut edge finishing.

Standard bores for single-row brushes

We can change the standard bores according to your adapter.

Please see the below table to define the articles for standard bores for single-row brushes.

Ø Brush		Ø Bore (mm)	0002007413	0002007415	0002007416	0002007419	0002007420	0002007422	0002007425	0002007430	0002007431	0002007432	0002007435	0002007438	0002007440	0002007444	0002007450
mm	"	Zoll / Inch (")	13	15,9 5/8"	16	19 3/4"	20	22,2 7/8"	25,4 1"	30	31,75 1 1/4"	32	35	38	40	44	50,8 2"
75	3		✓														
100	4		✓	✓	✓	✓	✓										
125	5		✓	✓	✓	✓	✓	✓	✓	✓	✓						
150	6		✓	✓	✓	✓	✓	✓	✓	✓	✓	✓	✓				
178	7		✓	✓	✓	✓	✓	✓	✓	✓	✓	✓	✓	✓			
200	8					✓	✓	✓	✓	✓	✓	✓	✓	✓			
250	10						✓	✓	✓	✓	✓	✓	✓	✓	✓		
300	12								✓	✓	✓	✓	✓	✓	✓	✓	
350	14										✓	✓	✓	✓	✓	✓	✓

Brushes altered to bore 50,8/2" can be further reduced by 4M adapters with keyways.

Standard bores for multiple-row brushes

Via pipe mounted multiple-row brushes are reduced through assembly of our on stock robust metal adapters.

Please see below table for available adapters according to pipe diameter.

Article numbers always start with 000200- and the respectable individual article number of the adapter is to be added to it in your order.

Ø Pipe		Ø Bore (mm)	9,53	10	12,7	13	16	19	20	22,2	25,4	30	31,8	32	35	40	50,8
mm	"	Zoll / Inch (")	3/8"		1/2"		5/8"	3/4"		7/8"	1"		1 1/4"				2"
20			8109	8110	8112	8113	8116										
30			8209	8210	8212	8213	8216	8219	8220	8222	8225						
50,8	2				8412	8413	8416	8419	8420	8422	8425	8430	8431	8432	8435		
80							8616	8619	8620	8622	8625	8630	8631	8632	8635	8640	8642
100									8720	8722	8725	8730	8731	8732	8735	8740	8742
120											8825	8830	8831	8832	8835	8840	8842

In case of doubt, don't hesitate to contact our Sales staff. We are happy to support you.



Important: If you don't state another bore with your order, the brush will be delivered to you with standard bore „B min“.

Brushtech Industrial Brushes

Wheel brushes

knotted wire



High performance version with knotted wire for demanding cleaning work and deburring.

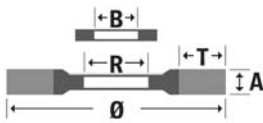

USAGE

	0,25	0,35	0,50	0,60	0,80
roughening	<input type="checkbox"/>	<input type="checkbox"/>	<input checked="" type="checkbox"/>	<input type="checkbox"/>	<input type="checkbox"/>
planing	<input type="checkbox"/>	<input type="checkbox"/>	<input type="checkbox"/>	<input type="checkbox"/>	<input type="checkbox"/>
deburring	<input checked="" type="checkbox"/>	<input checked="" type="checkbox"/>	<input checked="" type="checkbox"/>	<input type="checkbox"/>	<input type="checkbox"/>
edge honing	<input checked="" type="checkbox"/>	<input type="checkbox"/>	<input type="checkbox"/>	<input type="checkbox"/>	<input type="checkbox"/>
structuring	<input type="checkbox"/>	<input type="checkbox"/>	<input type="checkbox"/>	<input type="checkbox"/>	<input type="checkbox"/>
descaling/paint stripping	<input checked="" type="checkbox"/>	<input checked="" type="checkbox"/>	<input checked="" type="checkbox"/>	<input checked="" type="checkbox"/>	<input checked="" type="checkbox"/>
weld seams	<input checked="" type="checkbox"/>	<input checked="" type="checkbox"/>	<input checked="" type="checkbox"/>	<input checked="" type="checkbox"/>	<input checked="" type="checkbox"/>

TRIM AND MATERIAL

Products available with:

Steel wire twist knot →

Steel	Cast steel	Stainless steel	Non-ferrous metal	Aluminium	Soft wood	Hard wood
<input checked="" type="checkbox"/>	<input checked="" type="checkbox"/>	<input type="checkbox"/>	<input type="checkbox"/>	<input type="checkbox"/>	<input type="checkbox"/>	<input type="checkbox"/>

mm							0,35	RRP	0,50	RRP	0,80	RRP
Ø	A	T	B min.	B max.	rpm	pcs.	Order-No.	€	Order-No.	€	Order-No.	€
200	13	42	20	40	8500	1	0002-664 131		0002-664 151		0002-664 181	
200	26	42	50,8	50,8	8500	1			0002-664 152			
250	15	42	25,4	40	4500	2	0002-676 131		0002-676 151		0002-676 181	
300	18	55	25,4	40	3600	2	0002-686 131		0002-686 151		0002-686 181	

For other bore sizes, see table "Standard bore for single-row brushes" on page 108.

Joint brushes

knotted wire



For road building to clean expansion joints/gaps and narrow spots with thin working width.

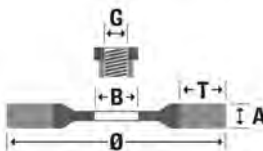

mm							0,50	RRP	0,80	RRP
Ø	A	T	B	rpm	pcs.	Order-No.	€	Order-No.	€	Order-No.
300	4	65	20	4500	6	9802-026 560				
300	6	65	20	4500	6	9802-026 561		9802-026 581		
300	8	65	20	4500	6	9802-026 562		9802-026 582		
300	10	65	20	4500	6	9802-026 563		9802-026 583		

For other bore sizes, see table "Standard bore for single-row brushes" on page 108.

Brushtech Industrial Brushes

Wheel brushes crimped wire



Narrow version for easy self-installation to achieve larger working widths.

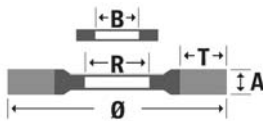

USAGE

	0,15	0,20	0,25/0,27	0,30	0,35	0,40	0,50
roughening	<input type="checkbox"/>	<input type="checkbox"/>	<input type="checkbox"/>	<input type="checkbox"/>	<input type="checkbox"/>	<input type="checkbox"/>	<input type="checkbox"/>
planing	<input type="checkbox"/>	<input type="checkbox"/>	<input type="checkbox"/>	<input type="checkbox"/>	<input type="checkbox"/>	<input type="checkbox"/>	<input type="checkbox"/>
deburring	<input type="checkbox"/>	<input type="checkbox"/>	<input type="checkbox"/>	<input type="checkbox"/>	<input type="checkbox"/>	<input type="checkbox"/>	<input type="checkbox"/>
edge honing	<input type="checkbox"/>	<input type="checkbox"/>	<input type="checkbox"/>	<input type="checkbox"/>	<input type="checkbox"/>	<input type="checkbox"/>	<input type="checkbox"/>
structuring	<input type="checkbox"/>	<input type="checkbox"/>	<input type="checkbox"/>	<input type="checkbox"/>	<input type="checkbox"/>	<input type="checkbox"/>	<input type="checkbox"/>
descaling/paint stripping	<input type="checkbox"/>	<input type="checkbox"/>	<input type="checkbox"/>	<input type="checkbox"/>	<input type="checkbox"/>	<input type="checkbox"/>	<input type="checkbox"/>
weld seams	<input type="checkbox"/>	<input type="checkbox"/>	<input type="checkbox"/>	<input type="checkbox"/>	<input type="checkbox"/>	<input type="checkbox"/>	<input type="checkbox"/>

TRIM AND MATERIAL

Products available with:

Steel wire crimped

Stainless steel

Steel	Cast steel	Stainless steel	Non-ferrous metal	Aluminium	Soft wood	Hard wood
<input checked="" type="checkbox"/>	<input checked="" type="checkbox"/>	<input checked="" type="checkbox"/>	<input checked="" type="checkbox"/>	<input checked="" type="checkbox"/>	<input checked="" type="checkbox"/>	<input checked="" type="checkbox"/>

mm							0,20	RRP	0,30	RRP
Ø	A	T	B min.	B max.	rpm	pcs.	Order-No.	€	Order-No.	€
75	11	15	13	13	10000	5			0002-511 161	
100	13	23	13	20	8000	8	0002-522 141		0002-522 161	
125	15	35	13	20	6000	5			0002-532 161	
150	16	32	13	20	6000	4	0002-544 141			
150	16	32	13	20	6000	8			0002-544 161	
178	18	45	13	32	6000	4	0002-554 141			
178	18	45	13	32	6000	8			0002-554 161	
200	19	38	19	32	4500	1			0002-566 161	
200	19	38	19	50,8	3000	2	0002-566 141			
250	22	35	20	50,8	3600	2	0002-576 141		0002-576 161	
300	26	58	20	50,8	3000	1			0002-587 161	

For other bore sizes, see table "Standard bore for single-row brushes" on page 108.

mm							0,20	RRP	0,30	RRP
Ø	A	T	B min.	B max.	rpm	pcs.	Order-No.	€	Order-No.	€
100	13	23	13	20	8000	8	0002-522 341		0002-522 361	
125	15	35	13	20	6000	5			0002-532 361	
150	16	32	13	32	6000	3	0002-544 341		0002-544 361	
178	18	45	13	32	6000	4	0002-554 341		0002-554 361	
200	19	38	19	50,8	4500	2			0002-566 361	
250	22	35	20	50,8	3600	2	0002-576 341		0002-576 361	
300	26	58	20	50,8	3000	2	0002-587 341			

For other bore sizes, see table "Standard bore for single-row brushes" on page 108.

Band-saw-brush



To remove chips on the band saw or circular saw blades in order to protect the teeth. Increases the service life of the saw blade and optimizes cutting accuracy. Nylon trim for plastics and wood.

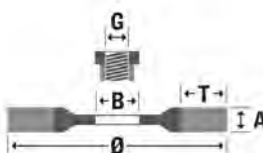

mm							Nylon 0,80	RRP
Ø	A	T	B	rpm	pcs.	Order-No.	€	
100	15	20	13	8000	10	0003-515 827		

Brushtech Industrial Brushes

Wheel brushes

crimped Osborn wire



Narrow version for easy self-installation to achieve larger working widths, combining several brushes on one shaft. Specially hardened wire for industrial applications.

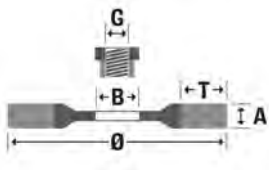

USAGE

	0,15	0,20	0,25/0,27	0,30	0,35	0,40	0,50
roughening	<input type="checkbox"/>	<input type="checkbox"/>	<input type="checkbox"/>	<input type="checkbox"/>	<input type="checkbox"/>	<input type="checkbox"/>	<input type="checkbox"/>
planing	<input type="checkbox"/>	<input type="checkbox"/>	<input type="checkbox"/>	<input type="checkbox"/>	<input type="checkbox"/>	<input type="checkbox"/>	<input type="checkbox"/>
deburring	<input type="checkbox"/>	<input type="checkbox"/>	<input type="checkbox"/>	<input type="checkbox"/>	<input type="checkbox"/>	<input type="checkbox"/>	<input type="checkbox"/>
edge honing	<input type="checkbox"/>	<input type="checkbox"/>	<input type="checkbox"/>	<input type="checkbox"/>	<input type="checkbox"/>	<input type="checkbox"/>	<input type="checkbox"/>
structuring	<input type="checkbox"/>	<input type="checkbox"/>	<input type="checkbox"/>	<input type="checkbox"/>	<input type="checkbox"/>	<input type="checkbox"/>	<input type="checkbox"/>
descaling/paint stripping	<input type="checkbox"/>	<input type="checkbox"/>	<input type="checkbox"/>	<input type="checkbox"/>	<input type="checkbox"/>	<input type="checkbox"/>	<input type="checkbox"/>
weld seams	<input type="checkbox"/>	<input type="checkbox"/>	<input type="checkbox"/>	<input type="checkbox"/>	<input type="checkbox"/>	<input type="checkbox"/>	<input type="checkbox"/>

TRIM AND MATERIAL

Products available with:

	Steel	Cast steel	Stainless steel	Non-ferrous metal	Aluminium	Soft wood	Hard wood
Steel wire crimped	<input checked="" type="checkbox"/>	<input checked="" type="checkbox"/>	<input type="checkbox"/>	<input type="checkbox"/>	<input type="checkbox"/>	<input type="checkbox"/>	<input type="checkbox"/>
Stainless steel	<input type="checkbox"/>	<input type="checkbox"/>	<input checked="" type="checkbox"/>	<input checked="" type="checkbox"/>	<input checked="" type="checkbox"/>	<input type="checkbox"/>	<input type="checkbox"/>

mm								Osborn 0,15	RRP	Osborn 0,20	RRP	Osborn 0,30	RRP
Ø	A	T	B	Adapt.	rpm	pcs.	Order-No.	€	Order-No.	€	Order-No.	€	
200	18	38	50,8	1-A	4500	2	9906-021 183		9906-021 184				
200	22	37	50,8	1-A	4500	1	9906-022 081		9906-022 082				
200	22	37	50,8	1-A	4500	2					9906-022 085		
250	26	60	50,8	4-M	3600	2			9906-013 008		9906-013 009		
300	28	60	50,8	4-M	3000	2					9906-013 021		
380	32	72	50,8	4-M	2400	2					9906-013 057		

For other bore sizes, see Adapters on page 117.

mm								Osborn 0,26	RRP	
Ø	A	T	B	Adapt.	rpm	pcs.	Order-No.	€	Order-No.	€
150	14	29	31,75	3-A	6000	6	9906-021 059			

For other bore sizes, see Adapters on page 117.

Wheel brushes

crimped wire



Compatible deburring brush with high wire density for use in stationary machines such as benchtop grinders and tabletop deburrers.

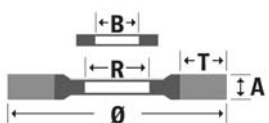

USAGE

	0,15	0,20	0,25/0,27	0,30	0,35	0,40	0,50
roughening	<input type="checkbox"/>	<input type="checkbox"/>	<input type="checkbox"/>	<input type="checkbox"/>	<input type="checkbox"/>	<input type="checkbox"/>	<input type="checkbox"/>
planing	<input type="checkbox"/>	<input type="checkbox"/>	<input type="checkbox"/>	<input type="checkbox"/>	<input type="checkbox"/>	<input type="checkbox"/>	<input type="checkbox"/>
deburring	<input type="checkbox"/>	<input type="checkbox"/>	<input type="checkbox"/>	<input type="checkbox"/>	<input type="checkbox"/>	<input type="checkbox"/>	<input type="checkbox"/>
edge honing	<input type="checkbox"/>	<input type="checkbox"/>	<input type="checkbox"/>	<input type="checkbox"/>	<input type="checkbox"/>	<input type="checkbox"/>	<input type="checkbox"/>
structuring	<input type="checkbox"/>	<input type="checkbox"/>	<input type="checkbox"/>	<input type="checkbox"/>	<input type="checkbox"/>	<input type="checkbox"/>	<input type="checkbox"/>
descaling/paint stripping	<input type="checkbox"/>	<input type="checkbox"/>	<input type="checkbox"/>	<input type="checkbox"/>	<input type="checkbox"/>	<input type="checkbox"/>	<input type="checkbox"/>
weld seams	<input type="checkbox"/>	<input type="checkbox"/>	<input type="checkbox"/>	<input type="checkbox"/>	<input type="checkbox"/>	<input type="checkbox"/>	<input type="checkbox"/>

TRIM AND MATERIAL

Products available with:

	Steel	Cast steel	Stainless steel	Non-ferrous metal	Aluminium	Soft wood	Hard wood
Steel wire crimped	<input checked="" type="checkbox"/>	<input checked="" type="checkbox"/>	<input type="checkbox"/>	<input type="checkbox"/>	<input type="checkbox"/>	<input type="checkbox"/>	<input type="checkbox"/>
Stainless steel	<input type="checkbox"/>	<input type="checkbox"/>	<input checked="" type="checkbox"/>	<input checked="" type="checkbox"/>	<input checked="" type="checkbox"/>	<input type="checkbox"/>	<input type="checkbox"/>

mm								0,20	RRP	0,30	RRP	0,50	RRP
Ø	A	T	B min.	B max.	R	rpm	pcs.	Order-No.	€	Order-No.	€	Order-No.	€
75	19	16		20	20	10000	4			9902-511 162			
100	20	23		20	30	8000	5	9902-522 142		9902-522 162			
100	28	23		20	30	8000	5			9902-522 163			
125	22	30		20	30	6000	5	9902-532 142		9902-532 162			
125	30	30		20	30	6000	5			9902-532 163			
150	21	25		31,75	50,8	6000	3	9902-544 441		9902-544 461		9902-544 491	
150	30	29		31,75	50,8	6000	3	9902-544 142		9902-544 162			
150	37	29		31,75	50,8	6000	3			9902-544 163		9902-544 193	
178	23	38		31,75	50,8	6000	1	9902-554 441		9902-554 461			
178	32	38		31,75	50,8	6000	1	9902-554 142		9902-554 162		9902-554 192	
178	38	38		31,75	50,8	6000	1			9902-554 163			
200	20	38		31,75	80	4500	1	9902-566 441		9902-566 461		9902-566 491	
200	30	38		31,75	80	4500	1	9902-566 142		9902-566 162		9902-566 192	
200	38	38		31,75	80	4500	1	9902-566 143		9902-566 163		9902-566 193	
250	28	47	20	50,8	100	3600	1	9902-576 142		9902-576 162		9902-576 192	
250	38	47	20	50,8	100	3600	1	9902-576 143		9902-576 163		9902-576 193	
250	55	47	20	50,8	100	3600	1			9902-576 464			
300	32	50	25,4	50,8	120	3000	1	9902-587 142		9902-587 162		9902-587 192	
300	46	50	50,8	101,6	151		1			0002-587 162			
300	44	50	25,4	50,8	120	3000	1	9902-587 143		9902-587 163		9902-587 193	

Brushtech Industrial Brushes

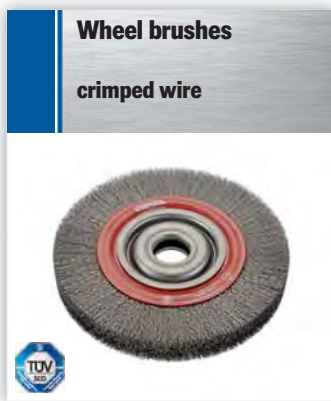

Wheel brushes
crimped wire

Compatible deburring brush with high wire density for use in stationary machines such as benchtop grinders and tabletop deburrers.

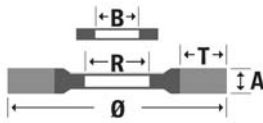

USAGE

roughening	<input type="checkbox"/>	<input type="checkbox"/>	<input type="checkbox"/>	<input type="checkbox"/>	<input type="checkbox"/>	<input type="checkbox"/>	<input type="checkbox"/>	<input type="checkbox"/>
planing	<input type="checkbox"/>	<input type="checkbox"/>	<input type="checkbox"/>	<input type="checkbox"/>	<input type="checkbox"/>	<input type="checkbox"/>	<input type="checkbox"/>	<input type="checkbox"/>
deburring	<input type="checkbox"/>	<input type="checkbox"/>	<input type="checkbox"/>	<input type="checkbox"/>	<input type="checkbox"/>	<input type="checkbox"/>	<input type="checkbox"/>	<input type="checkbox"/>
edge honing	<input type="checkbox"/>	<input type="checkbox"/>	<input type="checkbox"/>	<input type="checkbox"/>	<input type="checkbox"/>	<input type="checkbox"/>	<input type="checkbox"/>	<input type="checkbox"/>
structuring	<input type="checkbox"/>	<input type="checkbox"/>	<input type="checkbox"/>	<input type="checkbox"/>	<input type="checkbox"/>	<input type="checkbox"/>	<input type="checkbox"/>	<input type="checkbox"/>
descaling/paint stripping	<input type="checkbox"/>	<input type="checkbox"/>	<input type="checkbox"/>	<input type="checkbox"/>	<input type="checkbox"/>	<input type="checkbox"/>	<input type="checkbox"/>	<input type="checkbox"/>
weld seams	<input type="checkbox"/>	<input type="checkbox"/>	<input type="checkbox"/>	<input type="checkbox"/>	<input type="checkbox"/>	<input type="checkbox"/>	<input type="checkbox"/>	<input type="checkbox"/>

TRIM AND MATERIAL

Products available with:

Steel wire crimped	<input checked="" type="checkbox"/>	<input type="checkbox"/>	<input type="checkbox"/>	<input type="checkbox"/>	<input type="checkbox"/>	<input type="checkbox"/>	<input type="checkbox"/>
Stainless steel	<input type="checkbox"/>	<input checked="" type="checkbox"/>	<input checked="" type="checkbox"/>	<input checked="" type="checkbox"/>	<input type="checkbox"/>	<input type="checkbox"/>	<input type="checkbox"/>

mm								0,20	RRP	0,30	RRP		
Ø	A	T	B min.	B max.	R	rpm	pcs.	Order-No.	€	Order-No.	€	BOrder-No.	€
75	19	16		20	20	10000	4			9902-511 362			
100	20	23		20	30	8000	4	9902-522 342		9902-522 362			
100	28	23		20	30	8000	4			9902-522 363			
125	22	30		20	30	6000	2	9902-532 342		9902-532 362			
125	30	30		20	30	6000	2	9902-532 343		9902-532 363			
150	21	25		31,75	50,8	6000	2	9902-544 341		9902-544 361			
150	30	29		31,75	50,8	6000	2	9902-544 342		9902-544 362			
178	23	38		31,75	50,8	6000	1	9902-554 341		9902-554 361			
178	32	38		31,75	50,8	6000	1			9902-554 362			
200	20	38		31,75	80	4500	1	9902-566 341		9902-566 361			
200	30	38		31,75	80	4500	1	9902-566 342		9902-566 362			
200	38	38		31,75	80	4500	1			9902-566 363			
250	28	47	20	50,8	100	3600	1	9902-576 342		9902-576 362			
250	38	47	20	50,8	100	3600	1	9902-576 343		9902-576 363			
300	32	50	25,4	50,8	120	3000	1	9902-587 342		9902-587 362			
300	44	50	25,4	50,8	120	3000	1	9902-587 343		9902-587 363			

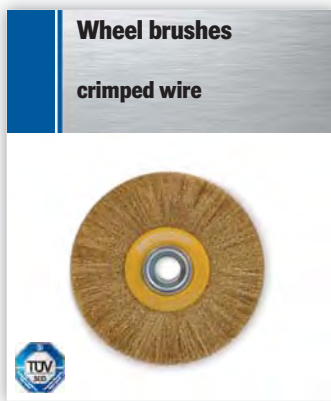

Wheel brushes
crimped wire

Flexible, soft wheel brush for fine surface finishing. Conforms to the contours of the work piece thanks to its long bristles.

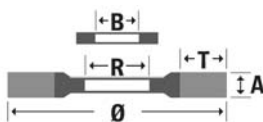

USAGE

roughening	<input type="checkbox"/>	<input type="checkbox"/>	<input type="checkbox"/>	<input type="checkbox"/>	<input type="checkbox"/>	<input type="checkbox"/>	<input type="checkbox"/>	<input type="checkbox"/>
planing	<input type="checkbox"/>	<input type="checkbox"/>	<input type="checkbox"/>	<input type="checkbox"/>	<input type="checkbox"/>	<input type="checkbox"/>	<input type="checkbox"/>	<input type="checkbox"/>
deburring	<input type="checkbox"/>	<input type="checkbox"/>	<input type="checkbox"/>	<input type="checkbox"/>	<input type="checkbox"/>	<input type="checkbox"/>	<input type="checkbox"/>	<input type="checkbox"/>
edge honing	<input type="checkbox"/>	<input type="checkbox"/>	<input type="checkbox"/>	<input type="checkbox"/>	<input type="checkbox"/>	<input type="checkbox"/>	<input type="checkbox"/>	<input type="checkbox"/>
structuring	<input type="checkbox"/>	<input type="checkbox"/>	<input type="checkbox"/>	<input type="checkbox"/>	<input type="checkbox"/>	<input type="checkbox"/>	<input type="checkbox"/>	<input type="checkbox"/>
descaling/paint stripping	<input type="checkbox"/>	<input type="checkbox"/>	<input type="checkbox"/>	<input type="checkbox"/>	<input type="checkbox"/>	<input type="checkbox"/>	<input type="checkbox"/>	<input type="checkbox"/>
weld seams	<input type="checkbox"/>	<input type="checkbox"/>	<input type="checkbox"/>	<input type="checkbox"/>	<input type="checkbox"/>	<input type="checkbox"/>	<input type="checkbox"/>	<input type="checkbox"/>

TRIM AND MATERIAL

Products available with:

Steel wire crimped	<input checked="" type="checkbox"/>	<input type="checkbox"/>	<input type="checkbox"/>	<input type="checkbox"/>	<input type="checkbox"/>	<input type="checkbox"/>	<input type="checkbox"/>
Stainless steel	<input type="checkbox"/>	<input checked="" type="checkbox"/>	<input checked="" type="checkbox"/>	<input checked="" type="checkbox"/>	<input type="checkbox"/>	<input type="checkbox"/>	<input type="checkbox"/>
Brass wire	<input type="checkbox"/>	<input type="checkbox"/>	<input type="checkbox"/>	<input checked="" type="checkbox"/>	<input checked="" type="checkbox"/>	<input type="checkbox"/>	<input type="checkbox"/>

mm								0,20	RRP	0,30	RRP		
Ø	A	T	B min.	B max.	R	rpm	pcs.	Order-No.	€	Order-No.	€	Order-No.	€
150	24	43		20	30	6000	3	9902-543 142		9902-543 162			
150	32	43		20	30	6000	3			9902-543 163			
178	32	43		31,75	50,8	6000	1			9902-553 162			
178	40	43		31,75	50,8	6000	1			9902-553 163			
200	33	55		31,75	50,8	4500	1	9902-565 142		9902-565 162			
200	42	55		31,75	50,8	4500	1	9902-565 143		9902-565 163			
250	32	63	20	50,8	80	3600	1	9902-575 142		9902-575 162			
250	42	63	20	50,8	80	3600	1			9902-575 163			
300	33	70	25,4	50,8	100	3000	1	9902-586 142		9902-586 162			
300	45	70	25,4	50,8	100	3000	1			9902-586 163			

mm								0,20	RRP	0,30	RRP		
Ø	A	T	B min.	B max.	R	rpm	pcs.	Order-No.	€	Order-No.	€	Order-No.	€
150	24	43		20	30	6000	2			9902-543 362			
178	32	43		31,75	50,8	6000	1	9902-553 342		9902-553 362			
200	33	55		31,75	50,8	4500	1	9902-565 342		9902-565 362			
250	32	63	20	50,8	80	3600	1	9902-575 342					
300	33	70	25,4	50,8	100	3000	1	9902-586 342		9902-586 362			
300	45	70	25,4	50,8	100	3000	1	9902-586 343		9902-586 363			

mm								0,20	RRP	0,30	RRP		
Ø	A	T	B min.	B max.	R	rpm	pcs.	Order-No.	€	Order-No.	€	Order-No.	€
150	24	43		20	30	6000	2	9902-543 542		9902-543 562			
150	32	43		20	30	6000	2	9902-543 543		9902-543 563			
178	32	43		31,75	50,8	6000	1	9902-553 542		9902-553 562			
200	33	55		31,75	50,8	4500	1	9902-565 542		9902-565 562			

i Universal usage of the brushes through a range of bore adapters:
Ø 75-125 mm: 20 mm = 1/2"; 5/8" **Ø 150-200 mm:** 31,75 mm = 1 3/8"; 15mm; 16mm; 19mm; 20 mm; 7/8"; 1".
Important: When ordering brushes Ø 250-300 mm please clearly state your arbor hole requirements.

Brushtech Industrial Brushes

Wheel brushes for deburring machines crimped wire



Very wide and compact brush for tabletop deburrers for finishing cut edges.

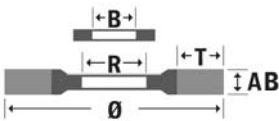

USAGE

roughening	<input type="checkbox"/>	<input type="checkbox"/>	<input type="checkbox"/>	<input type="checkbox"/>	<input type="checkbox"/>	<input type="checkbox"/>	<input type="checkbox"/>
planing	<input type="checkbox"/>	<input type="checkbox"/>	<input type="checkbox"/>	<input type="checkbox"/>	<input type="checkbox"/>	<input type="checkbox"/>	<input type="checkbox"/>
deburring	<input type="checkbox"/>	<input type="checkbox"/>	<input type="checkbox"/>	<input type="checkbox"/>	<input type="checkbox"/>	<input type="checkbox"/>	<input type="checkbox"/>
edge honing	<input type="checkbox"/>	<input type="checkbox"/>	<input type="checkbox"/>	<input type="checkbox"/>	<input type="checkbox"/>	<input type="checkbox"/>	<input type="checkbox"/>
structuring	<input type="checkbox"/>	<input type="checkbox"/>	<input type="checkbox"/>	<input type="checkbox"/>	<input type="checkbox"/>	<input type="checkbox"/>	<input type="checkbox"/>
descaling/paint stripping	<input type="checkbox"/>	<input type="checkbox"/>	<input type="checkbox"/>	<input type="checkbox"/>	<input type="checkbox"/>	<input type="checkbox"/>	<input type="checkbox"/>
weld seams	<input type="checkbox"/>	<input type="checkbox"/>	<input type="checkbox"/>	<input type="checkbox"/>	<input type="checkbox"/>	<input type="checkbox"/>	<input type="checkbox"/>

TRIM AND MATERIAL

Products available with:

Steel wire crimped	<input checked="" type="checkbox"/>	<input type="checkbox"/>	<input type="checkbox"/>	<input type="checkbox"/>	<input type="checkbox"/>	<input type="checkbox"/>	<input type="checkbox"/>
Stainless steel	<input type="checkbox"/>	<input type="checkbox"/>	<input checked="" type="checkbox"/>	<input checked="" type="checkbox"/>	<input checked="" type="checkbox"/>	<input type="checkbox"/>	<input type="checkbox"/>

mm								0,20	RRP	0,30	RRP	0,35	RRP
Ø	AB	KB	T	B	R	rpm	pcs.	Order-No.	€	Order-No.	€	Order-No.	€
250	60	55	45	100	100	3600	1	0002-576 145		0042-576 165		0042-576 175	

mm								0,50	RRP				
Ø	AB	KB	T	B	R	rpm	pcs.	Order-No.	€	Order-No.	€	Order-No.	€
250	60	55	45	100	100	3600	1	0002-576 195					

mm								0,20	RRP	0,30	RRP	0,35	RRP
Ø	AB	KB	T	B	R	rpm	pcs.	Order-No.	€	Order-No.	€	Order-No.	€
250	60	55	45	100	100	3600	1	0002-576 345		0042-576 365		0042-576 375	

mm								0,50	RRP				
Ø	AB	KB	T	B	R	rpm	pcs.	Order-No.	€	Order-No.	€	Order-No.	€
250	60	55	45	100	100	3600	1	0002-576 395					

For other bore sizes, see Axle discs on page 114.

Wheel brushes for deburring machines abrasive filament



Very wide and compact brush for tabletop deburrers for finishing cut edges.

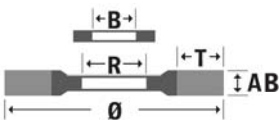

USAGE

roughening	<input checked="" type="checkbox"/>	<input checked="" type="checkbox"/>	<input checked="" type="checkbox"/>	<input checked="" type="checkbox"/>	<input checked="" type="checkbox"/>	<input checked="" type="checkbox"/>	<input checked="" type="checkbox"/>
planing	<input type="checkbox"/>	<input type="checkbox"/>	<input type="checkbox"/>	<input type="checkbox"/>	<input type="checkbox"/>	<input type="checkbox"/>	<input type="checkbox"/>
deburring	<input type="checkbox"/>	<input type="checkbox"/>	<input type="checkbox"/>	<input type="checkbox"/>	<input type="checkbox"/>	<input type="checkbox"/>	<input type="checkbox"/>
edge honing	<input type="checkbox"/>	<input type="checkbox"/>	<input type="checkbox"/>	<input type="checkbox"/>	<input type="checkbox"/>	<input type="checkbox"/>	<input type="checkbox"/>
structuring	<input type="checkbox"/>	<input type="checkbox"/>	<input type="checkbox"/>	<input type="checkbox"/>	<input type="checkbox"/>	<input type="checkbox"/>	<input type="checkbox"/>
descaling/paint stripping	<input checked="" type="checkbox"/>	<input checked="" type="checkbox"/>	<input checked="" type="checkbox"/>	<input checked="" type="checkbox"/>	<input checked="" type="checkbox"/>	<input checked="" type="checkbox"/>	<input checked="" type="checkbox"/>
weld seams	<input type="checkbox"/>	<input type="checkbox"/>	<input type="checkbox"/>	<input type="checkbox"/>	<input type="checkbox"/>	<input type="checkbox"/>	<input type="checkbox"/>

TRIM AND MATERIAL

Products available with:

Abrasive bristle	<input checked="" type="checkbox"/>	<input type="checkbox"/>	<input type="checkbox"/>	<input type="checkbox"/>	<input type="checkbox"/>	<input type="checkbox"/>	<input type="checkbox"/>
------------------	-------------------------------------	--------------------------	--------------------------	--------------------------	--------------------------	--------------------------	--------------------------

mm								grit 80/1,27	RRP	grit 120/1,02	RRP	grit 180/0,90	RRP
Ø	AB	KB	T	B	R	rpm	pcs.	Order-No.	€	Order-No.	€	Order-No.	€
250	60	55	45	100	100	3600	1	2102-576 916		0002-576 906		0002-576 916	

mm								grit 320/0,56	RRP				
Ø	AB	KB	T	B	R	rpm	pcs.	Order-No.	€	Order-No.	€	Order-No.	€
250	60	55	45	100	100	3600	1	0002-576 926					

For other bore sizes, see Axle discs on page 114.

Brushtech Industrial Brushes

Wheel brushes for deburring machines crimped wire

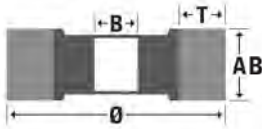

USAGE

	0,15	0,20	0,25/0,27	0,30	0,35	0,40	0,50
roughening	<input type="checkbox"/>	<input type="checkbox"/>	<input type="checkbox"/>	<input type="checkbox"/>	<input type="checkbox"/>	<input type="checkbox"/>	<input type="checkbox"/>
planing	<input checked="" type="checkbox"/>	<input checked="" type="checkbox"/>	<input checked="" type="checkbox"/>	<input checked="" type="checkbox"/>	<input checked="" type="checkbox"/>	<input checked="" type="checkbox"/>	<input checked="" type="checkbox"/>
deburring	<input checked="" type="checkbox"/>	<input checked="" type="checkbox"/>	<input checked="" type="checkbox"/>	<input checked="" type="checkbox"/>	<input checked="" type="checkbox"/>	<input checked="" type="checkbox"/>	<input checked="" type="checkbox"/>
edge honing	<input checked="" type="checkbox"/>	<input checked="" type="checkbox"/>	<input checked="" type="checkbox"/>	<input checked="" type="checkbox"/>	<input checked="" type="checkbox"/>	<input checked="" type="checkbox"/>	<input checked="" type="checkbox"/>
structuring	<input type="checkbox"/>	<input type="checkbox"/>	<input type="checkbox"/>	<input type="checkbox"/>	<input type="checkbox"/>	<input type="checkbox"/>	<input type="checkbox"/>
descaling/paint stripping	<input type="checkbox"/>	<input type="checkbox"/>	<input type="checkbox"/>	<input type="checkbox"/>	<input type="checkbox"/>	<input type="checkbox"/>	<input type="checkbox"/>
weld seams	<input checked="" type="checkbox"/>	<input checked="" type="checkbox"/>	<input checked="" type="checkbox"/>	<input checked="" type="checkbox"/>	<input checked="" type="checkbox"/>	<input checked="" type="checkbox"/>	<input checked="" type="checkbox"/>

TRIM AND MATERIAL

Products available with:

Steel wire crimped

Stainless steel

Steel	Cast steel	Stainless steel	Non-ferrous metal	Aluminium	Soft wood	Hard wood
<input checked="" type="checkbox"/>	<input checked="" type="checkbox"/>	<input checked="" type="checkbox"/>	<input type="checkbox"/>	<input type="checkbox"/>	<input type="checkbox"/>	<input type="checkbox"/>

mm									0,35	RRP	0,35	RRP	0,30	RRP
Ø	AB	KB	T	B	R		rpm	pcs.	Order-No.	€	Order-No.	€	Order-No.	€
300	460	440	60	120	120		3600	1	4602-743 178		7602-743 378		1302-753 368	
300	620	600	60	120	120		3600	1	8802-753 478					

Price on request.

More wheel brushes for all common deburring machines available on request.

Axle plates



mm			Order-No.	Order-No.	Order-No.
B	Keyway	pcs.	Order-No.	Order-No.	Order-No.
50,8	13,2x7,1	1	5495-560 051		
52,9	13,5x6,4	1	5495-560 052		
54,7	13,6x5,8	1	5495-560 054		
80,2	13,5x7,5	1	5495-560 080		
82	13,5x6,4	1	5495-560 082		

Price on request.

One-way axle discs for tabletop deburrers.

Brushtech Industrial Brushes

Wheel brushes abrasive filament



Abrasive bristle for wet and dry applications. Resistant to weak acids and alkaline solutions. Flexible, the brush adapts to the work piece. Industrial version.

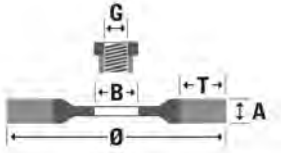

USAGE

	40/46	60	80	120	180	320	Fibre
roughening	<input checked="" type="checkbox"/>	<input checked="" type="checkbox"/>	<input checked="" type="checkbox"/>	<input checked="" type="checkbox"/>	<input checked="" type="checkbox"/>	<input checked="" type="checkbox"/>	<input type="checkbox"/>
planing	<input type="checkbox"/>	<input type="checkbox"/>	<input type="checkbox"/>	<input type="checkbox"/>	<input type="checkbox"/>	<input type="checkbox"/>	<input type="checkbox"/>
deburring	<input type="checkbox"/>	<input type="checkbox"/>	<input type="checkbox"/>	<input checked="" type="checkbox"/>	<input checked="" type="checkbox"/>	<input checked="" type="checkbox"/>	<input type="checkbox"/>
edge honing	<input type="checkbox"/>	<input type="checkbox"/>	<input type="checkbox"/>	<input checked="" type="checkbox"/>	<input checked="" type="checkbox"/>	<input checked="" type="checkbox"/>	<input type="checkbox"/>
structuring	<input type="checkbox"/>	<input type="checkbox"/>	<input type="checkbox"/>	<input checked="" type="checkbox"/>	<input checked="" type="checkbox"/>	<input checked="" type="checkbox"/>	<input type="checkbox"/>
descaling/paint stripping	<input checked="" type="checkbox"/>	<input checked="" type="checkbox"/>	<input checked="" type="checkbox"/>	<input checked="" type="checkbox"/>	<input checked="" type="checkbox"/>	<input checked="" type="checkbox"/>	<input type="checkbox"/>
weld seams	<input type="checkbox"/>	<input type="checkbox"/>	<input type="checkbox"/>	<input type="checkbox"/>	<input type="checkbox"/>	<input type="checkbox"/>	<input checked="" type="checkbox"/>

TRIM AND MATERIAL

Products available with:

Abrasive bristle →

<input checked="" type="checkbox"/>	Steel
<input checked="" type="checkbox"/>	Cast steel
<input checked="" type="checkbox"/>	Stainless steel
<input checked="" type="checkbox"/>	Non-ferrous metal
<input checked="" type="checkbox"/>	Aluminium
<input checked="" type="checkbox"/>	Soft wood
<input checked="" type="checkbox"/>	Hard wood

mm									grit 80	RRP	grit 120 1,02	RRP	grit 180	RRP
Ø	A	T	B	Adapt.	rpm	pcs.			Order-No.	€	Order-No.	€	Order-No.	€
75	12	15	5/8"	F	20000	6			9906-015 001		9906-015 002		9906-015 003	
100	13	20	5/8"	F	12000	6			9906-015 025		9906-015 026		9906-015 027	
125	16	30	5/8"	F	12000	6			9906-015 035		9906-015 036		9906-015 037	
150	17	32	7/8"	F	8000	6			9906-015 079		9906-015 080		9906-015 081	
178	20	47	7/8"	F	8000	2			9906-015 040		9906-015 041		9906-015 042	
200	18	35	2"	4-M	6000	2			9906-015 050		9906-015 051		9906-015 052	
250	18	35	2"	4-M	3000	2			9906-015 056		9906-015 057		9906-015 058	
250	18	60	2"	4-M	3600	2			9946-015 056		9946-015 057		9946-015 058	
300	18	35	2"	4-M	2400	2			9906-015 062		9906-015 063		9906-015 064	
300	18	60	2"	4-M	3000	2					9966-015 063		9966-015 064	
350	19	55	2"	4-M	2400	2					9906-015 069		9906-015 070	

mm									grit 320	RRP	grit 120 0,65	RRP		
Ø	A	T	B	Adapt.	rpm	pcs.			Order-No.	€	Order-No.	€	Order-No.	€
75	12	15	5/8"	F	20000	6			9906-015 004					
100	13	20	5/8"	F	12000	6			9906-015 028		9916-015 026			
125	16	30	5/8"	F	12000	6			9906-015 038					
150	17	32	7/8"	F	8000	6			9906-015 082					
178	20	47	7/8"	F	8000	2			9906-015 043		9916-015 041			
200	18	35	2"	4-M	6000	2			9906-015 053		9916-015 051			
250	18	35	2"	4-M	3000	2			9906-015 059		9916-015 057			
250	18	60	2"	4-M	3600	2			9946-015 059					
300	18	35	2"	4-M	2400	2			9906-015 065					
300	18	60	2"	4-M	3000	2			9966-015 065					
350	19	55	2"	4-M	2400	2			9906-015 071		9916-015 069			

Brushtech Industrial Brushes

Wheel brushes abrasive filament



Abrasive bristle for dry applications.

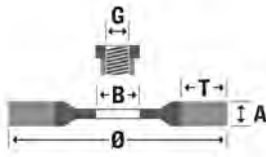

USAGE

	40/46	60	80	120	180	320	Fibre
roughening	<input checked="" type="checkbox"/>	<input checked="" type="checkbox"/>	<input checked="" type="checkbox"/>	<input checked="" type="checkbox"/>	<input checked="" type="checkbox"/>	<input checked="" type="checkbox"/>	<input type="checkbox"/>
planing	<input type="checkbox"/>	<input type="checkbox"/>	<input type="checkbox"/>	<input type="checkbox"/>	<input type="checkbox"/>	<input type="checkbox"/>	<input type="checkbox"/>
deburring	<input type="checkbox"/>	<input type="checkbox"/>	<input type="checkbox"/>	<input type="checkbox"/>	<input type="checkbox"/>	<input type="checkbox"/>	<input type="checkbox"/>
edge honing	<input type="checkbox"/>	<input type="checkbox"/>	<input type="checkbox"/>	<input type="checkbox"/>	<input type="checkbox"/>	<input type="checkbox"/>	<input type="checkbox"/>
structuring	<input type="checkbox"/>	<input type="checkbox"/>	<input type="checkbox"/>	<input type="checkbox"/>	<input type="checkbox"/>	<input type="checkbox"/>	<input type="checkbox"/>
descaling/paint stripping	<input type="checkbox"/>	<input type="checkbox"/>	<input type="checkbox"/>	<input type="checkbox"/>	<input type="checkbox"/>	<input type="checkbox"/>	<input type="checkbox"/>
weld seams	<input type="checkbox"/>	<input type="checkbox"/>	<input type="checkbox"/>	<input type="checkbox"/>	<input type="checkbox"/>	<input type="checkbox"/>	<input type="checkbox"/>

TRIM AND MATERIAL

Products available with:

Abrasive bristle

<input type="checkbox"/>	Steel	<input type="checkbox"/>	Cast steel	<input type="checkbox"/>	Stainless steel	<input type="checkbox"/>	Non-ferrous metal	<input type="checkbox"/>	Aluminium	<input type="checkbox"/>	Soft wood	<input type="checkbox"/>	Hard wood
--------------------------	-------	--------------------------	------------	--------------------------	-----------------	--------------------------	-------------------	--------------------------	-----------	--------------------------	-----------	--------------------------	-----------

mm				grit 80	RRP	grit 120	RRP	grit 180	RRP				
Ø	A	T	B min.	B max.	Adapt.	rpm	pcs.	Order-No.	€	Order-No.	€	Order-No.	€
75	12	13		13		20000	6	9902-515 001		9902-515 002		9902-515 003	
100	18	18	13	20		12000	6	9902-515 025		9902-515 026		9902-515 027	
150	18	32	13	32	F	8000	6	9902-515 079		9902-515 080		9902-515 081	
178	20	45	13	32	F	8000	4	9902-515 040		9902-515 041		9902-515 042	
200	18	35	19	50,8	4-M	6000	2	9902-515 050		9902-515 051		9902-515 052	
250	20	35	20	50,8	4-M	3600	2	9902-515 056		9902-515 057		9902-515 058	
250	18	60	20	50,8	4-M	3000	2	9962-515 056		9962-515 057		9962-515 058	
300	20	35	20	50,8	4-M	2400	2	9902-515 062		9902-515 063		9902-515 064	
300	20	60	20	50,8	4-M	3000	2	9962-515 062		9962-515 063		9962-515 064	
350	20	57	32	50,8	4-M	2400	2			9902-515 069			

mm				Novofil 320	RRP								
Ø	A	T	B min.	B max.	Adapt.	rpm	pcs.	Order-No.	€	Order-No.	€	Order-No.	€
75	12	13		13		20000	6	9902-515 004					
100	18	18	13	20		12000	6	9902-515 028					
150	18	32	13	32	F	8000	6	9902-515 082					
178	18	45	13	32	F	8000	4	9902-515 043					
200	18	35	19	50,8	4-M	6000	2	9902-515 053					
250	18	60	20	50,8	4-M	3000	2	9962-515 059					
300	20	35	20	50,8	4-M	2400	2	9902-515 065					
300	20	60	20	50,8	4-M	3000	2	9962-515 065					

For other bore sizes, see table "Standard bore for single-row brushes" on page 108.

End brushes crimped wire



To deburr the raw edge of tubes/profiles or flat surfaces. A set (8, 16, 24 pcs) are fitted in a brush head.

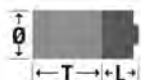

USAGE

	80	120	180	20	0,20	0,27	0,35	0,50
roughening	<input type="checkbox"/>	<input type="checkbox"/>	<input type="checkbox"/>	<input type="checkbox"/>	<input type="checkbox"/>	<input type="checkbox"/>	<input type="checkbox"/>	<input type="checkbox"/>
planing	<input type="checkbox"/>	<input type="checkbox"/>	<input type="checkbox"/>	<input type="checkbox"/>	<input type="checkbox"/>	<input type="checkbox"/>	<input type="checkbox"/>	<input type="checkbox"/>
deburring	<input type="checkbox"/>	<input type="checkbox"/>	<input type="checkbox"/>	<input type="checkbox"/>	<input type="checkbox"/>	<input type="checkbox"/>	<input type="checkbox"/>	<input type="checkbox"/>
edge honing	<input type="checkbox"/>	<input type="checkbox"/>	<input type="checkbox"/>	<input type="checkbox"/>	<input type="checkbox"/>	<input type="checkbox"/>	<input type="checkbox"/>	<input type="checkbox"/>
structuring	<input type="checkbox"/>	<input type="checkbox"/>	<input type="checkbox"/>	<input type="checkbox"/>	<input type="checkbox"/>	<input type="checkbox"/>	<input type="checkbox"/>	<input type="checkbox"/>
descaling/paint stripping	<input type="checkbox"/>	<input type="checkbox"/>	<input type="checkbox"/>	<input type="checkbox"/>	<input type="checkbox"/>	<input type="checkbox"/>	<input type="checkbox"/>	<input type="checkbox"/>
weld seams	<input type="checkbox"/>	<input type="checkbox"/>	<input type="checkbox"/>	<input type="checkbox"/>	<input type="checkbox"/>	<input type="checkbox"/>	<input type="checkbox"/>	<input type="checkbox"/>

TRIM AND MATERIAL

Products available with:

Steel wire straight

Stainless steel

Abrasive bristle

<input type="checkbox"/>	Steel	<input type="checkbox"/>	Cast steel	<input type="checkbox"/>	Stainless steel	<input type="checkbox"/>	Non-ferrous metal	<input type="checkbox"/>	Aluminium	<input type="checkbox"/>	Soft wood	<input type="checkbox"/>	Hard wood
--------------------------	-------	--------------------------	------------	--------------------------	-----------------	--------------------------	-------------------	--------------------------	-----------	--------------------------	-----------	--------------------------	-----------

mm				0,20	RRP	0,35	RRP	0,50	RRP
Ø	T	L	pcs.	Order-No.	€	Order-No.	€	Order-No.	€
25	95	25	16	0002-509 448		0002-509 478		0002-509 498	

mm				0,20	RRP	grit 80	RRP	grit 120 0,20 rostfrei	RRP
Ø	T	L	pcs.	Order-No.	€	Order-No.	€	Order-No.	€
25	95	25	16	0002-509 348		0002-509 908		5702-509 938	

Brushtech Industrial Brushes



4-M adapter for thin wheel brushes with bore 2" (50.8 mm) tapered grooves; reusable.

mm		pcs.	Order-No.	RRP			
B	Inch			€	Order-No.	€	Order-No.
12,7	1/2"	1	0003-075 064				
16	5/8"	1	0003-075 065				
19	3/4"	1	0003-075 066				
22,2	7/8"	1	0003-075 067				
25,4	1"	1	0003-075 068				
28	1 1/8"	1	0003-075 069				
31,75	1 1/4"	1	0003-075 070				
38	1 1/2"	1	0003-075 071				
50,8	2"	1	0003-075 073				



For reduction of arbor holes.

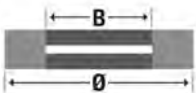

Inch		pcs.	Order-No.	UVP			
Inner Ø	Outer Ø			€	Order-No.	€	Order-No.
1/2"	5/8"	1	0003-000 223				
3/8"	7/8"	1	0003-000 242				
1/2"	7/8"	1	0003-000 243				
5/8"	7/8"	1	0003-000 244				

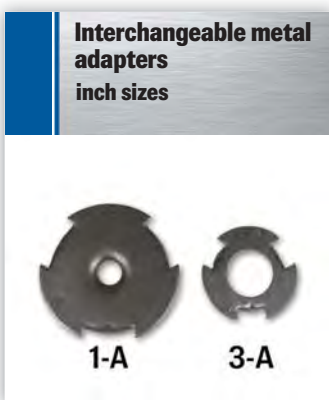

1-A adapter for bore 2" (50,8 mm) round; reusable.

3-A adapter for bore 1 1/4" (31,75 mm) round; reusable.

Inch		pcs.	1-A		3-A		RRP	
B			Order-No.	€	Order-No.	€	Order-No.	€
1/2"		1	0103-075 021		0103-075 048			
3/4"		1			0103-075 050			
1 1/4"		1	0103-075 027					
1 1/2"		1	0103-075 028					

BRUSHTECHNOLOGY
INDUSTRIAL

Brushtech Industrial Brushes



1-A adapter for bore 2" (50,8 mm) round; reusable.

3-A adapter for bore 1 1/4" (31,75 mm) round; reusable.

mm		1-A	RRP	3-A	RRP		
B	pcs.	Order-No.	€	Order-No.	€	Order-No.	€
10	1	0103-075 210					
13	1	0103-075 213		0103-075 313			
16	1	0103-075 216		0103-075 316			
20	1	0103-075 220		0103-075 320			
25	1	0103-075 225		0103-075 325			
30	1	0103-075 230					
32	1	0103-075 232					
35	1	0103-075 235					
40	1	0103-075 240					



Brushtech Industrial

Internal finishing



Important user information

Brushes for internal finishing

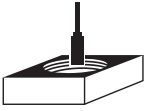

To be noted when selecting brushes for internal finishing:

1. General user information

Brushes for internal finishing are suitable for use with hand-held and stationary tools with drill or jaw chucks and tool spindles. Some products are designed exclusively for manual operation.

2. Typical brushes for internal finishing

Some typical brushes used for internal finishing are shown below. The product overview on the following pages provides details of the whole range.



Helituf



Novoflex B



Novoflex S1



Micro-abrasive tube brush

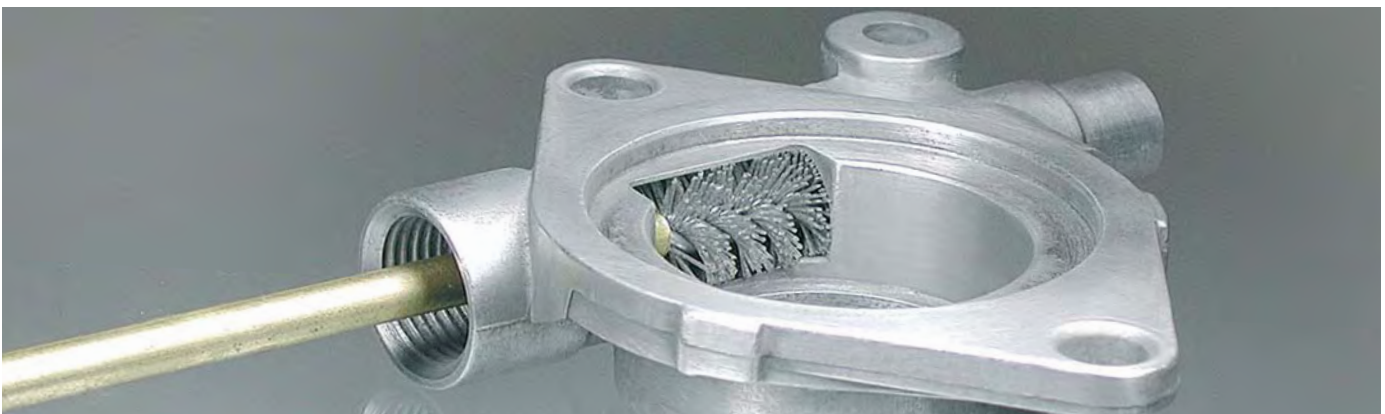



Finding the right tool

Please check your product choice using the information in the info heading. This will tell you the application for each product and its suitability, as well as providing a summary of the available trim materials suitable for the material being finished.

USE	NHA 600/NHS 1000	Nylon-diamond 400+800	Orig. Osb. wire 0.08-0.20	Filament brush 80-320	Novoflex WF 120+320	Crimped steel wire 0.15-0.50	Nylon/Natural fibre
Internal cleaning, general	<input type="checkbox"/>	<input type="checkbox"/>	<input type="checkbox"/>	<input type="checkbox"/>	<input type="checkbox"/>	<input type="checkbox"/>	<input type="checkbox"/>
Deburring	<input type="checkbox"/>	<input type="checkbox"/>	<input type="checkbox"/>	<input type="checkbox"/>	<input type="checkbox"/>	<input type="checkbox"/>	<input type="checkbox"/>
Brushing edges/tapered grooves	<input type="checkbox"/>	<input type="checkbox"/>	<input type="checkbox"/>	<input type="checkbox"/>	<input type="checkbox"/>	<input type="checkbox"/>	<input type="checkbox"/>
Rust removal	<input type="checkbox"/>	<input type="checkbox"/>	<input type="checkbox"/>	<input type="checkbox"/>	<input type="checkbox"/>	<input type="checkbox"/>	<input type="checkbox"/>
Cleaning threads/holes	<input type="checkbox"/>	<input type="checkbox"/>	<input type="checkbox"/>	<input type="checkbox"/>	<input type="checkbox"/>	<input type="checkbox"/>	<input type="checkbox"/>
Plateau finish	<input type="checkbox"/>	<input type="checkbox"/>	<input type="checkbox"/>	<input type="checkbox"/>	<input type="checkbox"/>	<input type="checkbox"/>	<input type="checkbox"/>

TRIM AND MATERIALW	Steel	Cast Iron	Stainless steel	Non-ferrous metal	Aluminium	Softwood	Hardwood
Product available with:							
Steel wire, knotted	<input checked="" type="checkbox"/>	<input checked="" type="checkbox"/>	<input type="checkbox"/>	<input type="checkbox"/>	<input type="checkbox"/>	<input type="checkbox"/>	<input type="checkbox"/>
Steel wire, crimped	<input checked="" type="checkbox"/>	<input checked="" type="checkbox"/>	<input type="checkbox"/>	<input type="checkbox"/>	<input type="checkbox"/>	<input type="checkbox"/>	<input type="checkbox"/>
Steel wire, stainless	<input type="checkbox"/>	<input type="checkbox"/>	<input checked="" type="checkbox"/>	<input checked="" type="checkbox"/>	<input checked="" type="checkbox"/>	<input type="checkbox"/>	<input type="checkbox"/>
Brass wire	<input type="checkbox"/>	<input type="checkbox"/>	<input type="checkbox"/>	<input checked="" type="checkbox"/>	<input checked="" type="checkbox"/>	<input type="checkbox"/>	<input type="checkbox"/>
Abrasive bristle	<input type="checkbox"/>	<input type="checkbox"/>	<input type="checkbox"/>	<input type="checkbox"/>	<input type="checkbox"/>	<input type="checkbox"/>	<input type="checkbox"/>
Nylon-diamond	<input checked="" type="checkbox"/>	<input checked="" type="checkbox"/>	<input checked="" type="checkbox"/>	<input checked="" type="checkbox"/>	<input checked="" type="checkbox"/>	<input checked="" type="checkbox"/>	<input checked="" type="checkbox"/>
Natural bristle	<input checked="" type="checkbox"/>	<input checked="" type="checkbox"/>	<input checked="" type="checkbox"/>	<input checked="" type="checkbox"/>	<input checked="" type="checkbox"/>	<input checked="" type="checkbox"/>	<input checked="" type="checkbox"/>

PROFESSIONAL INTERNAL FINISHING

	Product and material	Properties	Use
<p>SITUFT</p> 	<p>Internal brushes with crimped original Osborn wire, fastened in a wing-shaped form.</p>	<p>Quick and easy to clamp in a wide variety of machines using different adapters. Designed for hand-held (e.g. pneumatic and electric tools), as well as stationary machines. The brushes can be clamped in collet chucks, jaw chucks and tool spindles.</p>	<p>For cleaning holes and internal surfaces that are difficult to reach, as well as longitudinal grooves.</p>
<p>i Clockwise or anti-clockwise operation possible using an adapter. Can only be used in a clockwise direction without an adapter. The larger the diameter, the greater the flexibility of the brush.</p>			
<p>HELITUF</p> 	<p>Internal brushes with original crimped Osborn wire, fastened in a spiral construction.</p>	<p>Designed for hand-held machines. The brushes can be mounted in drill sockets and on spindles. Chuck mounting is also possible using a Helituf adapter. The spiral-shaped construction simulates a stroke action.</p>	<p>To clean and deburr holes, to brush and deburr edges and tapered grooves.</p>
<p>i An adapter can be used to increase the total length (incl. brush) to 225 mm.</p>			
<p>Micro-abrasive</p> 	<p>Tube brushes with flexible silicon carbide or aluminium oxide trim. Special shaft available upon request.</p>	<p>For use in CNC and NC machines, as well as processing centres.</p>	<p>To clean condensers and boiler pipes, deburr, clean and roughen coated surfaces.</p>
<p>i Brushes should be 5 – 10% larger than the diameter of the hole.</p>			

Brushtech Industrial

Internal finishing

	Product and material	Properties	Use
<p>Nylon-diamond</p>  <p>spiral-shaped</p>	<p>Tube brush, spiral-shaped Galvanised twisted wire, stabilised with shaft of pressed brass sleeve.</p>	<p>Flexible trim; after heavy usage and deformation the filaments will recover. Filaments flex rather than break.</p> <p>High flexibility and high performance.</p> <p>Easy clamping in collet and jaw chucks.</p>	<p>Edge rounding, deburring of cross holes, further finishing of honed surfaces.</p> <p>Surface roughness reduced significantly.</p> <p>Ideal for finishing hard components (e.g. ceramic), hardened parts, precision components and parts for spiral-shaped aerospace applications.</p>

i Brushes should be 10 – 15% larger than the diameter of the hole.

<p>Nylon-diamond</p>  <p>wing-shaped</p>	<p>Tube brushes, wing-shaped Galvanised twisted wire, stabilised with shaft of pressed brass sleeve.</p>	<p>Because of their very thin and flexible trim, the life of these brushes is longer than that of conventional brushes with a harder trim.</p>	<p>Deburring and finishing, e.g. of longitudinal grooves.</p>
--	--	--	---

i Brushes should be 10 – 15% larger than the diameter of the hole.

<p>Novoflex-B</p>  <p>rpm 350 – 700</p>	<p>Sturdy, self-centring honing tool. Flexible design with abrasive spheres.</p>	<p>Suitable for hand-held and honing machines. For use in CNC and NC machines, processing centres and automatic equipment, clamping in tool spindles also possible.</p>	<p>Edge breaks, final finishing of top surfaces. For use in non-round bores and for deburring and finishing of bearing holes during engine production.</p> <p>To create an even, fine-ground surface with a high contact ratio (plateau finish). The resulting cross-hatching is an ideal base for oil film adhesion.</p>
---	--	---	---

i Lubricants must always be used. We recommend lubricating the Novoflex-B with honing oil before use. Mineral oil, engine oil, water-soluble oil or cooling lubricants can be used as alternatives. Honing time: 20 – 40 sec. The process time can be reduced for deburring longitudinal and cross holes. Clean the bore using hot water and detergent and Osborn nylon tube brushes.

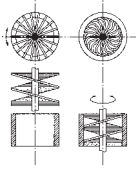
Product and material	Properties	Use
<p>Novoflex-H</p>  <p>Flat brush with wing-shaped trim material, double wire core. Shaped on the outer contact surfaces to provide a larger working surface.</p> 	<p>Flexible trim; after heavy usage and deformation the filaments will recover. Filaments flex rather than break.</p> <p>These honing brushes are used in a clockwise, oscillating movement.</p> <p>Easy clamping in collet and jaw chucks.</p>	<p>Surface finishing of workpieces that do not require deburring, e.g. internal finishing of pipes, manufacture of piston pumps, engines.</p>



Brushes should be up to 25% larger than the diameter of the hole.

Hole cleaning brushes, nozzle cleaning brushes, fitting brushes, terminal post brushes

In crimped wire or nylon
With handle



For manual use



Internal cleaning of a wide range of materials, from steel or copper to wood and plastic.



Brushtechnology Industrial

Internal finishing

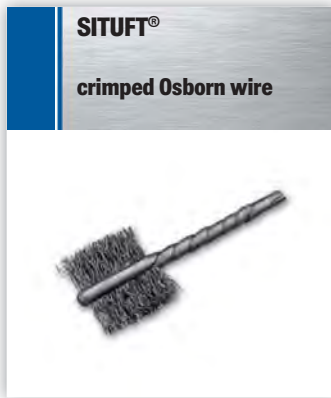

Double wire core for compressed air and electric tools. Adapter to fix in various power tools.

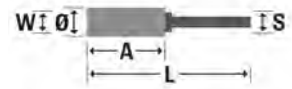

W = workpiece diameter

USAGE

Internal cleaning

Deburring

Brush edges/tapered grooves

Derust

Thread/drill hole cleaning

Plateau finish

NiH 600/NiS 1000

Nylon Dam 400-600

Org. Dis. Wire 0,08-0,20

Alumina bristles 80-320

Repoli WF 0,08-0,20

Comp. steelwires 0,15-0,50

Nylon/natural

TRIM AND MATERIAL

Products available with:

Steel wire crimped →

Stainless steel →

Steel

Cast steel

Stainless steel

Non-ferrous metal

Aluminium

Soft wood

Hard wood

mm						Osborn 0,08	RRP	Osborn 0,13	RRP	Osborn 0,20	RRP
W	Ø	A	L	S	pcs.	Order-No.	€	Order-No.	€	Order-No.	€
6,4	6,7	14	54	2,38	12	9907-035 021 *		9907-035 023 *			
8	8,4	14	54	2,38	12	9907-035 031 *		9907-035 032 *			
9,5	10	14	54	2,38	12	9907-035 041		9907-035 042 *			
11	11,5	14	54	2,38	12	9907-035 051		9907-035 052 *			
13	13,1	14	54	3,18	12	9907-035 061		9907-035 062 *			
14	14,5	16	54	3,18	12	9907-035 081		9907-035 082		9907-035 083 *	
16	16,3	16	54	3,18	12	9907-035 086		9907-035 087 *		9907-035 088	
18	19,2	16	54	3,18	12			9907-035 092		9907-035 093	
19	20,1	16	54	3,18	12	9907-035 096		9907-035 097		9907-035 098 *	
21	21,9	16	57	3,18	12			9907-035 102			
22	22,8	16	57	3,18	12			9907-035 107			
25	26	16	57	3,18	12			9907-035 117		9907-035 118 *	
29	29,8	16	57	3,18	12			9907-035 127		9907-035 128	
32	32,6	16	57	3,18	12			9907-035 137		9907-035 138 *	

* Parts included in the SITUFT®Set (Order-No. 9907-035 000).

mm						Osborn 0,13	RRP				
W	Ø	A	L	S	pcs.	Order-No.	€	Order-No.	€	Order-No.	€
6	6,7	14	54	2,38	12	9907-035 181					
13	13,1	14	54	3,18	12	9907-035 197					
16	16,3	16	54	3,18	12	9907-035 205					
19	20,1	16	54	3,18	12	9907-035 213					
22	22,8	16	57	3,18	12	9907-035 221					
25	26	16	57	3,18	12	9907-035 229					

* Parts included in the SITUFT®Set (Order-No. 9907-035 000).

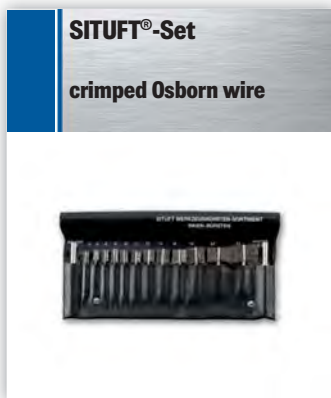

SITUFT® Set: 12 brushes D6 to D32 and two adapters. Parts in this set are marked by an asterisk in the previous table.

USAGE

Internal cleaning

Deburring

Brush edges/tapered grooves

Derust

Thread/drill hole cleaning

Plateau finish

NiH 600/NiS 1000

Nylon Dam 400-600

Org. Dis. Wire 0,08-0,20

Alumina bristles 80-320

Repoli WF 0,08-0,20

Comp. steelwires 0,15-0,50

Nylon/natural

TRIM AND MATERIAL

Products available with:

Steel wire crimped →

Stainless steel →

Steel

Cast steel

Stainless steel

Non-ferrous metal

Aluminium

Soft wood

Hard wood

pcs.	Order-No.	€	Order-No.	€	Order-No.	€
1	9907-035 000					

Brushtechology Industrial Internal finishing

HELITUF® crimped Osborn wire



Double wire core for automatic or manual applications. Adapter available to extend length up to max. 225 mm (details below).

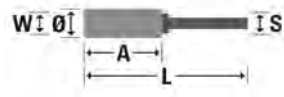

W = workpiece diameter

	USAGE	NH4600/NH31000 Nylon Dam 400-800 Dig. Oak Wire 0,08-0,20 Abrasive bristle 80-320 Norell VWF 0,01-0,20 Cera. stainless 0,15-0,60 Nylon natural	<table border="0"> <tr><td>Internal cleaning</td><td><input type="checkbox"/></td><td><input type="checkbox"/></td><td><input type="checkbox"/></td><td><input type="checkbox"/></td><td><input type="checkbox"/></td></tr> <tr><td>Deburring</td><td><input checked="" type="checkbox"/></td><td><input checked="" type="checkbox"/></td><td><input checked="" type="checkbox"/></td><td><input checked="" type="checkbox"/></td><td><input checked="" type="checkbox"/></td></tr> <tr><td>Brush edges/tapered grooves</td><td><input checked="" type="checkbox"/></td><td><input checked="" type="checkbox"/></td><td><input checked="" type="checkbox"/></td><td><input checked="" type="checkbox"/></td><td><input checked="" type="checkbox"/></td></tr> <tr><td>Derust</td><td><input type="checkbox"/></td><td><input type="checkbox"/></td><td><input type="checkbox"/></td><td><input type="checkbox"/></td><td><input type="checkbox"/></td></tr> <tr><td>Thread/drill hole cleaning</td><td><input checked="" type="checkbox"/></td><td><input checked="" type="checkbox"/></td><td><input checked="" type="checkbox"/></td><td><input checked="" type="checkbox"/></td><td><input checked="" type="checkbox"/></td></tr> <tr><td>Plateau finish</td><td><input type="checkbox"/></td><td><input type="checkbox"/></td><td><input type="checkbox"/></td><td><input type="checkbox"/></td><td><input type="checkbox"/></td></tr> </table>	Internal cleaning	<input type="checkbox"/>	<input type="checkbox"/>	<input type="checkbox"/>	<input type="checkbox"/>	<input type="checkbox"/>	Deburring	<input checked="" type="checkbox"/>	<input checked="" type="checkbox"/>	<input checked="" type="checkbox"/>	<input checked="" type="checkbox"/>	<input checked="" type="checkbox"/>	Brush edges/tapered grooves	<input checked="" type="checkbox"/>	<input checked="" type="checkbox"/>	<input checked="" type="checkbox"/>	<input checked="" type="checkbox"/>	<input checked="" type="checkbox"/>	Derust	<input type="checkbox"/>	<input type="checkbox"/>	<input type="checkbox"/>	<input type="checkbox"/>	<input type="checkbox"/>	Thread/drill hole cleaning	<input checked="" type="checkbox"/>	<input checked="" type="checkbox"/>	<input checked="" type="checkbox"/>	<input checked="" type="checkbox"/>	<input checked="" type="checkbox"/>	Plateau finish	<input type="checkbox"/>	<input type="checkbox"/>	<input type="checkbox"/>	<input type="checkbox"/>	<input type="checkbox"/>	TRIM AND MATERIAL
Internal cleaning	<input type="checkbox"/>	<input type="checkbox"/>	<input type="checkbox"/>	<input type="checkbox"/>	<input type="checkbox"/>																																			
Deburring	<input checked="" type="checkbox"/>	<input checked="" type="checkbox"/>	<input checked="" type="checkbox"/>	<input checked="" type="checkbox"/>	<input checked="" type="checkbox"/>																																			
Brush edges/tapered grooves	<input checked="" type="checkbox"/>	<input checked="" type="checkbox"/>	<input checked="" type="checkbox"/>	<input checked="" type="checkbox"/>	<input checked="" type="checkbox"/>																																			
Derust	<input type="checkbox"/>	<input type="checkbox"/>	<input type="checkbox"/>	<input type="checkbox"/>	<input type="checkbox"/>																																			
Thread/drill hole cleaning	<input checked="" type="checkbox"/>	<input checked="" type="checkbox"/>	<input checked="" type="checkbox"/>	<input checked="" type="checkbox"/>	<input checked="" type="checkbox"/>																																			
Plateau finish	<input type="checkbox"/>	<input type="checkbox"/>	<input type="checkbox"/>	<input type="checkbox"/>	<input type="checkbox"/>																																			
	<table border="0"> <tr><td>Products available with:</td><td></td><td>Steel</td><td>Cast steel</td><td>Stainless steel</td><td>Non-ferrous metal</td><td>Aluminium</td><td>Soft wood</td><td>Hard wood</td></tr> <tr><td>Steel wire crimped</td><td>➔</td><td><input checked="" type="checkbox"/></td><td><input checked="" type="checkbox"/></td><td><input checked="" type="checkbox"/></td><td><input checked="" type="checkbox"/></td><td><input checked="" type="checkbox"/></td><td><input checked="" type="checkbox"/></td><td><input checked="" type="checkbox"/></td></tr> <tr><td>Stainless steel</td><td>➔</td><td><input checked="" type="checkbox"/></td><td><input checked="" type="checkbox"/></td><td><input checked="" type="checkbox"/></td><td><input checked="" type="checkbox"/></td><td><input checked="" type="checkbox"/></td><td><input type="checkbox"/></td><td><input type="checkbox"/></td></tr> </table>	Products available with:		Steel	Cast steel	Stainless steel	Non-ferrous metal	Aluminium	Soft wood	Hard wood	Steel wire crimped	➔	<input checked="" type="checkbox"/>	<input checked="" type="checkbox"/>	<input checked="" type="checkbox"/>	<input checked="" type="checkbox"/>	<input checked="" type="checkbox"/>	<input checked="" type="checkbox"/>	<input checked="" type="checkbox"/>	Stainless steel	➔	<input checked="" type="checkbox"/>	<input checked="" type="checkbox"/>	<input checked="" type="checkbox"/>	<input checked="" type="checkbox"/>	<input checked="" type="checkbox"/>	<input type="checkbox"/>	<input type="checkbox"/>												
Products available with:		Steel	Cast steel	Stainless steel	Non-ferrous metal	Aluminium	Soft wood	Hard wood																																
Steel wire crimped	➔	<input checked="" type="checkbox"/>	<input checked="" type="checkbox"/>	<input checked="" type="checkbox"/>	<input checked="" type="checkbox"/>	<input checked="" type="checkbox"/>	<input checked="" type="checkbox"/>	<input checked="" type="checkbox"/>																																
Stainless steel	➔	<input checked="" type="checkbox"/>	<input checked="" type="checkbox"/>	<input checked="" type="checkbox"/>	<input checked="" type="checkbox"/>	<input checked="" type="checkbox"/>	<input type="checkbox"/>	<input type="checkbox"/>																																

mm						Osborn 0,13	RRP	Osborn 0,20	RRP		
W	Ø	A	L	S	pcs.	Order-No.	€	Order-No.	€	Order-No.	€
6	7,95	25	89	3,4	12	9907-036 012					
8	9,5	25	89	3,4	12	9907-036 017					
10	11	25	89	3,4	12	9907-036 022		9907-036 023			
11	12,7	25	89	3,4	12	9907-036 027					
13	14,3	25	89	3,4	12	9907-036 032		9907-036 033			
14	15,9	25	89	3,4	12	9907-036 037					
16	17,5	25	89	3,4	12	9907-036 042		9907-036 043			
18	19	25	89	3,4	12	9907-036 047					
19	20,6	25	89	3,4	12	9907-036 052		9907-036 053			
21	22,2	25	89	3,4	12	9907-036 057					
22	23,8	25	89	3,4	12	9907-036 062		9907-036 063			
24	25,4	25	89	3,4	12	9907-036 067					
25	27	25	89	3,4	12	9907-036 072		9907-036 073			
29	30,1	25	89	3,4	12	9907-036 082					
32	33,3	25	89	3,4	12			9907-036 093			

mm						Osborn 0,13	RRP	Osborn 0,20	RRP		
W	Ø	A	L	S	pcs.	Order-No.	€	Order-No.	€	Order-No.	€
6	7,95	25	89	3,4	12	9907-036 139					
10	11,1	25	89	3,4	12	9907-036 147					
11	12,7	25	89	3,4	12	9907-036 151					
13	14,3	25	89	3,4	12	9907-036 155		9907-036 156			
16	17,5	25	89	3,4	12	9907-036 163		9907-036 164			
19	20,6	25	89	3,4	12			9907-036 172			
22	23,8	25	89	3,4	12	9907-036 179					
24	27	25	89	3,4	12			9907-036 188			
25	27	25	89	3,4	12	9907-036 187					
32	33,3	25	89	3,4	12			9907-036 204			

Tube & Internal Brushes crimped wire



	USAGE	NH4600/NH31000 Nylon Dam 400-800 Dig. Oak Wire 0,08-0,20 Abrasive bristle 80-320 Norell VWF 0,01-0,20 Cera. stainless 0,15-0,60 Nylon natural	<table border="0"> <tr><td>Internal cleaning</td><td><input type="checkbox"/></td><td><input type="checkbox"/></td><td><input type="checkbox"/></td><td><input type="checkbox"/></td><td><input type="checkbox"/></td></tr> <tr><td>Deburring</td><td><input checked="" type="checkbox"/></td><td><input checked="" type="checkbox"/></td><td><input checked="" type="checkbox"/></td><td><input checked="" type="checkbox"/></td><td><input checked="" type="checkbox"/></td></tr> <tr><td>Brush edges/tapered grooves</td><td><input checked="" type="checkbox"/></td><td><input checked="" type="checkbox"/></td><td><input checked="" type="checkbox"/></td><td><input checked="" type="checkbox"/></td><td><input checked="" type="checkbox"/></td></tr> <tr><td>Derust</td><td><input type="checkbox"/></td><td><input type="checkbox"/></td><td><input type="checkbox"/></td><td><input type="checkbox"/></td><td><input type="checkbox"/></td></tr> <tr><td>Thread/drill hole cleaning</td><td><input checked="" type="checkbox"/></td><td><input checked="" type="checkbox"/></td><td><input checked="" type="checkbox"/></td><td><input checked="" type="checkbox"/></td><td><input checked="" type="checkbox"/></td></tr> <tr><td>Plateau finish</td><td><input type="checkbox"/></td><td><input type="checkbox"/></td><td><input type="checkbox"/></td><td><input type="checkbox"/></td><td><input type="checkbox"/></td></tr> </table>	Internal cleaning	<input type="checkbox"/>	<input type="checkbox"/>	<input type="checkbox"/>	<input type="checkbox"/>	<input type="checkbox"/>	Deburring	<input checked="" type="checkbox"/>	<input checked="" type="checkbox"/>	<input checked="" type="checkbox"/>	<input checked="" type="checkbox"/>	<input checked="" type="checkbox"/>	Brush edges/tapered grooves	<input checked="" type="checkbox"/>	<input checked="" type="checkbox"/>	<input checked="" type="checkbox"/>	<input checked="" type="checkbox"/>	<input checked="" type="checkbox"/>	Derust	<input type="checkbox"/>	<input type="checkbox"/>	<input type="checkbox"/>	<input type="checkbox"/>	<input type="checkbox"/>	Thread/drill hole cleaning	<input checked="" type="checkbox"/>	<input checked="" type="checkbox"/>	<input checked="" type="checkbox"/>	<input checked="" type="checkbox"/>	<input checked="" type="checkbox"/>	Plateau finish	<input type="checkbox"/>	<input type="checkbox"/>	<input type="checkbox"/>	<input type="checkbox"/>	<input type="checkbox"/>	TRIM AND MATERIAL
Internal cleaning	<input type="checkbox"/>	<input type="checkbox"/>	<input type="checkbox"/>	<input type="checkbox"/>	<input type="checkbox"/>																																			
Deburring	<input checked="" type="checkbox"/>	<input checked="" type="checkbox"/>	<input checked="" type="checkbox"/>	<input checked="" type="checkbox"/>	<input checked="" type="checkbox"/>																																			
Brush edges/tapered grooves	<input checked="" type="checkbox"/>	<input checked="" type="checkbox"/>	<input checked="" type="checkbox"/>	<input checked="" type="checkbox"/>	<input checked="" type="checkbox"/>																																			
Derust	<input type="checkbox"/>	<input type="checkbox"/>	<input type="checkbox"/>	<input type="checkbox"/>	<input type="checkbox"/>																																			
Thread/drill hole cleaning	<input checked="" type="checkbox"/>	<input checked="" type="checkbox"/>	<input checked="" type="checkbox"/>	<input checked="" type="checkbox"/>	<input checked="" type="checkbox"/>																																			
Plateau finish	<input type="checkbox"/>	<input type="checkbox"/>	<input type="checkbox"/>	<input type="checkbox"/>	<input type="checkbox"/>																																			
	<table border="0"> <tr><td>Products available with:</td><td></td><td>Steel</td><td>Cast steel</td><td>Stainless steel</td><td>Non-ferrous metal</td><td>Aluminium</td><td>Soft wood</td><td>Hard wood</td></tr> <tr><td>Steel wire crimped</td><td>➔</td><td><input checked="" type="checkbox"/></td><td><input checked="" type="checkbox"/></td><td><input checked="" type="checkbox"/></td><td><input checked="" type="checkbox"/></td><td><input checked="" type="checkbox"/></td><td><input checked="" type="checkbox"/></td><td><input checked="" type="checkbox"/></td></tr> </table>	Products available with:		Steel	Cast steel	Stainless steel	Non-ferrous metal	Aluminium	Soft wood	Hard wood	Steel wire crimped	➔	<input checked="" type="checkbox"/>	<input checked="" type="checkbox"/>	<input checked="" type="checkbox"/>	<input checked="" type="checkbox"/>	<input checked="" type="checkbox"/>	<input checked="" type="checkbox"/>	<input checked="" type="checkbox"/>																					
Products available with:		Steel	Cast steel	Stainless steel	Non-ferrous metal	Aluminium	Soft wood	Hard wood																																
Steel wire crimped	➔	<input checked="" type="checkbox"/>	<input checked="" type="checkbox"/>	<input checked="" type="checkbox"/>	<input checked="" type="checkbox"/>	<input checked="" type="checkbox"/>	<input checked="" type="checkbox"/>	<input checked="" type="checkbox"/>																																

mm						0,15	RRP	0,20	RRP	
Ø	A	L	G	pcs.	Order-No.	€	Order-No.	€	Order-No.	€
10	100	140	M 6	10	0003-815 210					
12	100	140	M 6	10	0002-815 212					
14	100	140	M 6	10	0002-815 214					
15	100	140	5/16 Zoll	10	0002-812 215					
18	100	140	5/16 Zoll	5			0002-812 218			
20	100	140	5/16 Zoll	10			0002-812 220			

mm						0,30	RRP			
Ø	A	L	G	pcs.	Order-No.	€	Order-No.	€	Order-No.	€
25	100	160	1/2 Zoll	5	0002-808 125					
30	100	160	1/2 Zoll	5	0002-808 130					
32	100	160	1/2 Zoll	5	0002-808 132					
35	100	160	1/2 Zoll	5	0002-808 135					
36	100	160	1/2 Zoll	5	0002-808 136					
38	100	160	1/2 Zoll	5	0002-808 138					
40	100	160	1/2 Zoll	5	0002-808 140					
44	100	160	1/2 Zoll	5	0002-808 144					
50	100	160	1/2 Zoll	5	0002-808 150					

BRUSHTECHNOLOGY
INDUSTRIAL

Brushtech Industrial

Internal finishing

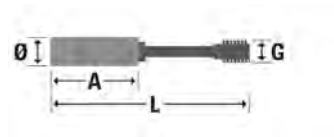

USAGE

Internal cleaning NH 600/NHS 1000
 Deburring Nylon Dam 400-800
 Brush edges/tapered grooves Org. Dis. Wire 036-020
 Derust Abrasive bristle 60-320
 Thread/drill hole cleaning Rough WF 020-320
 Plateau finish Comp. steelwires 0,5-0,60
Nylon/vitral

TRIM AND MATERIAL

Products available with:

Steel wire crimped → Steel Cast steel Stainless steel Non-ferrous metal Aluminium Soft wood Hard wood

mm					0,25	RRP	0,30	RRP	0,35	RRP
Ø	A	L	G	pcs.	Order-No.	€	Order-No.	€	Order-No.	€
25	100	160	1/2 Zoll BSW	5	0003-810 125					
28	100	160	1/2 Zoll BSW	5	0003-810 128					
30	100	160	1/2 Zoll BSW	5	0003-810 130					
32	100	160	1/2 Zoll BSW	5			0003-810 132			
38	100	160	1/2 Zoll BSW	5			0003-810 138			
40	100	160	1/2 Zoll BSW	5			0003-810 140			
44	100	160	1/2 Zoll BSW	5			0003-810 144			
50	100	160	1/2 Zoll BSW	5			0003-810 150			
57	100	160	1/2 Zoll BSW	5			0003-810 157			
63	100	160	1/2 Zoll BSW	5					0002-808 163	
75	100	160	1/2 Zoll BSW	5					0002-808 175	

mm					0,40	RRP	0,50	RRP
Ø	A	L	G	pcs.	Order-No.	€	Order-No.	€
63	100	160	1/2 Zoll BSW	5	0003-810 163			
69	100	160	1/2 Zoll BSW	5	0003-810 169			
75	100	160	1/2 Zoll BSW	5	0003-810 175			
82	100	160	1/2 Zoll BSW	5	0003-810 182			
100	100	160	1/2 Zoll BSW	5			0002-808 100	
101	100	160	1/2 Zoll BSW	5			0003-810 100	



G	L	pcs.	steel wire	RRP	RRP
			Order-No.	€	Order-No.
1/2 Zoll BSW	1000	10	0002-819 110		
M 6	1000	10	1132-819 110		
5/16 Zoll BSW	1000	10	1103-819 110		

Flexible – with a thread to extend heating element brushes and tube brushes.

Brushtechnology Industrial Internal finishing

Tube & Internal Brushes

abrasive trim



Zinc-plated twisted shaft with single trim spiral. For cross-hole deburring, control units, O-ring grooves and cylindrical components.

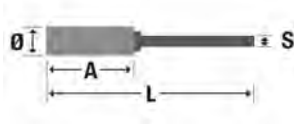



USAGE

Internal cleaning

Deburring

Brush edges/tapered grooves

Derust

Thread/drill hole cleaning

Plateau finish

NHA 600/NHS 1000
NHS 100mm 40x1800
Ding Ochs Werr 004-020
Abrasive trimm BS-220
Novofil 80-200
Cross rollers 135-048
Nipolmaterial

TRIM AND MATERIAL

Products available with:

Abrasive bristle → Steel Cast steel Stainless steel Non-ferrous metal Aluminium Soft wood Hard wood

mm						NHS 1000	RRP	NHA 600	RRP		
Ø	A	L	S	pcs.	Order-No.	€	Order-No.	€	Order-No.	€	
0,7	12	100	0,42	12	0003-056 400						
1,2	12	100	0,47	12	0003-056 403						
1,9	18	100	0,74	12	0003-056 406						
2,2	18	100	0,93	12	0003-056 409						
2,6	25	100	1,08	12	0003-056 412						
3,2	25	100	1,66	12	0003-056 415						
3,5	25	100	1,66	12	0003-056 418						
4,2	25	125	2,20	12			0003-056 425				
4,8	25	125	2,20	12			0003-056 427				
5,5	25	125	2,20	12			0003-056 428				
6,6	25	125	3,00	12			0003-056 429				
8,2	25	125	3,00	12			0003-056 432				
9,8	25	125	3,40	12			0003-056 435				
11,5	25	125	3,40	12			0003-056 436				
13	25	125	4,20	12			0003-056 438				
16	25	125	4,20	12			0003-056 441				
17,5	25	125	4,20	12			0003-056 442				
19,4	25	125	5,60	12			0003-056 444				
22,6	25	125	5,60	12			0003-056 447				
25,8	25	125	6,20	12			0003-056 450				

Tube & Internal Brushes

abrasive filament



Deburring cross-holes, control parts, O-Ring grooves and cylindrical bores. Recommendation: Brushes should be 10–15% larger than the bore.

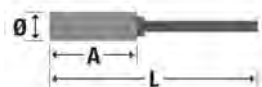



USAGE

Internal cleaning

Deburring

Brush edges/tapered grooves

Derust

Thread/drill hole cleaning

Plateau finish

Novofil 80
Novofil 120
Novofil 320
Cross rollers 135-048
Nipolmaterial

TRIM AND MATERIAL

Products available with:

Abrasive bristle → Steel Cast steel Stainless steel Non-ferrous metal Aluminium Soft wood Hard wood

mm						Novofil 80	RRP	Novofil 120	RRP	Novofil 320	RRP
Ø	A	L	S	pcs.	Order-No.	€	Order-No.	€	Order-No.	€	
6	50	125		12			0003-056 306			0003-056 326	
7	50	125		12			0003-056 307			0003-056 327	
8	50	125		12			0003-056 308			0003-056 328	
10	50	125		12		0003-056 010	0003-056 310			0003-056 330	
13	50	125		12		0002-056 011	0002-056 311			0002-056 331	
16	50	125		12		0002-056 012	0002-056 312			0002-056 332	
19	65	125		12		0002-056 013	0002-056 313			0002-056 333	
22	65	125		12		0002-056 014	0002-056 314			0002-056 334	
25	65	125		12		0002-056 015	0002-056 315			0002-056 335	
32	65	125		12		0002-056 016	0002-056 316			0002-056 336	
38	65	125		12		0002-056 017	0002-056 317			0002-056 337	
50	65	125		12		0002-056 018	0002-056 318			0002-056 338	

BRUSHTECHNOLOGY INDUSTRIAL

Brushtech Industrial

Internal finishing



Zinc-plated twisted shaft with brass stabilising sleeve.



USAGE

Internal cleaning

Deburring

Brush edges/tapered grooves

Derust

Thread/drill hole cleaning

Plateau finish

NH 600/NHS 1000
Nylon Diam 400-800
Drg. Dia. Wire 036-020
Abrasive bristle 60-320
Rough WF 020-320
Comp. Meshwire 0,5-0,6
Nylon/Natural

TRIM AND MATERIAL

Products available with: Nylon-Diamond

Steel Cast steel Stainless steel Non-ferrous metal Aluminium Soft wood Hard wood

mm						grit 400	RRP	grit 800	RRP		
W	A	L	S	pcs.	Order-No.	€	Order-No.	€	Order-No.	€	
2	20	100	1	2	0008-852 002 *						
2	20	100	1	10			0008-852 802				
2,5	20	100	1	2	0018-852 002 *						
2,5	20	100	1	10			0018-852 802				
3	20	100	1,5	2	0008-852 003 *						
3	20	100	1,5	10			0008-852 803				
3,5	20	100	1,5	2	0018-852 003 *						
3,5	20	100	1,5	10			0018-852 803				
4	20	115	3	2	0008-852 004		0008-852 804				
5	20	115	3	2	0008-852 005		0008-852 805				
6	20	115	3	2	0008-852 006		0008-852 806				
7	20	115	3	2	0008-852 007		0008-852 807				
8	20	115	3	2	0008-852 008		0008-852 808				
9	20	115	3	2	0008-852 009		0008-852 809				
10	20	115	4	2	0008-852 010		0008-852 810				
12	20	115	6	2	0008-852 012		0008-852 812				
15	20	115	6	2	0008-852 015		0008-852 815				
17	20	115	6	2	0008-852 017						
17	20	115	6	10			0008-852 817				
19	20	115	6	2	0008-852 019						
19	20	115	6	10			0008-852 819				
22	20	115	6	2	0008-852 022						
22	20	115	6	10			0008-852 822				
25	20	115	6	2	0008-852 025						
25	20	115	6	10			0008-852 825				

* without brass stabilising sleeve.



Flexible, self-centering honing tool. Achieves a plateau finish. Due to cross grinding a good carrier for oil film adhesion.

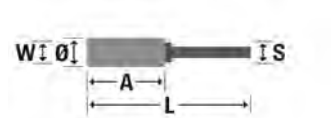

W = workpiece diameter

mm						grit SIC 120	RRP	grit SIC 180	RRP	grit SIC 240	RRP
W	Ø	A	L	S	pcs.	Order-No.	€	Order-No.	€	Order-No.	€
7	8	50	200	3,6	1			9828-036 308			
8	9	50	200	3,6	1	9818-036 309		9828-036 309			
9	10	50	200	3,6	1	9818-036 310		9828-036 310			
10	11	60	200	3,6	1	9818-036 311		9828-036 311		9838-036 311	
11	12	60	200	3,6	1	9818-036 312		9828-036 312			
12	13	60	200	3,6	1	9818-036 313		9828-036 313		9838-036 313	
14	15,5	60	200	3,6	1	9818-036 316		9828-036 316		9838-036 315	
16	18	60	200	4,6	1	9818-036 318		9828-036 318		9838-036 318	
18	20	60	200	4,6	1	9818-036 320		9828-036 320		9838-036 320	
20	22	70	200	4,6	1	9818-036 322		9828-036 322		9838-036 322	
22	25	70	200	4,6	1	9818-036 325		9828-036 325		9838-036 325	
24	27	70	200	5,1	1	9818-036 327		9828-036 327			
25	28	70	200	5,1	1	9818-036 328		9828-036 328		9838-036 328	
27	30	70	200	5,1	1	9818-036 330		9828-036 330		9838-036 330	
29	32	70	200	5,1	1	9818-036 332		9828-036 332		9838-036 332	
32	35	70	200	5,7	1	9818-036 335		9828-036 335		9838-036 335	
35	38	70	200	5,7	1	9818-036 338		9828-036 338			
38	41	70	200	5,7	1	9818-036 341		9828-036 341			
41	45	70	200	5,7	1	9818-036 345		9828-036 345		9838-036 345	
45	48	70	200	5,7	1	9818-036 348		9828-036 348		9838-036 348	
48	51	70	200	6,5	1	9818-036 351		9828-036 351			
48	51	76	203	6,5	1					9838-036 351	
51	54	70	200	6,5	1	9818-036 354		9828-036 354		9838-036 355	
54	57	70	200	6,5	1	9818-036 357		9828-036 357		9838-036 357	
57	60	70	200	7,3	1	9818-036 360		9828-036 360		9838-036 360	
60	64	70	200	7,3	1	9818-036 364		9828-036 364			

Brushtech Industrial Internal finishing



Oscillating use at approx. 600–1400 rpm.
Version with very dense trim.

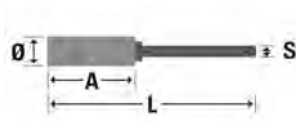

USAGE

Internal cleaning
 Deburring
 Brush edges/tapered grooves
 Derust
 Thread/drill hole cleaning
 Plateau finish

NH 600/MS 1000
 Nylon Dam 400-800
 Drg. Cut. Wire 0,08-0,20
 Abrasive bristle 80-320
 Novofil WF 020-320
 Cross section 0,15-0,50
 Nylon/Inlaid

TRIM AND MATERIAL

Products available with:

Abrasive bristle →

<input type="checkbox"/>	Steel
<input type="checkbox"/>	Cast steel
<input type="checkbox"/>	Stainless steel
<input type="checkbox"/>	Non-ferrous metal
<input type="checkbox"/>	Aluminium
<input type="checkbox"/>	Soft wood
<input type="checkbox"/>	Hard wood

mm						grit 120	RRP	grit 320	RRP		
Ø	A	L	S	pcs.	Order-No.	€	Order-No.	€	Order-No.	€	
19	22	90	3,18	6	9907-036 478						
26	23	86	3,18	12	9907-036 302						
26	32	86	3,18	12			9907-036 303				
29	38	96	3,18	6	9907-036 482						
29	50	125	6,35	12			9907-036 483				
35	50	125	6,35	2	9907-036 484						
38	50	125	6,35	2	9907-036 304				9907-036 305		
42	50	125	6,35	2	9907-036 491						
42	50	125	6,35	1			9907-036 490				
46	50	125	6,35	2	9907-036 489						
46	50	125	6,35	1			9907-036 488				
51	50	125	6,35	12	9907-036 306						
51	50	125	6,35	1			9907-036 307				
56	50	125	6,35	2	9907-036 486				9907-036 487		
63	89	160	9,53	2	9907-036 308				9907-036 309		
76	102	160	9,53	2	9907-036 310				9907-036 311		
89	102	160	9,53	2	9907-036 312						
89	102	160	9,53	12			9907-036 313				
102	102	160	9,53	2	9907-036 314				9907-036 315		
115	102	152	9,53	2	9907-036 316						
115	102	152	9,53	6			9907-036 317				
127	127	230	12,7	2	9907-036 318						
127	127	230	12,7	6			9907-036 319				
140	127	235	12,7	2	9907-036 320						
140	127	235	12,7	6			9907-036 321				
153	153	230	12,7	2	9907-036 322						
153	153	230	12,7	1			9907-036 323				



To clean the inside of steel, wood or plastic products. To remove chippings and loose particles.

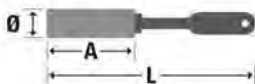

mm						0,15	RRP	0,20	RRP		
Ø	A	L	pcs.	Order-No.	€	Order-No.	€	Order-No.	€		
15	100	280	10	0002-892 215							
20	100	280	10				0002-892 220				
25	100	280	10				0002-892 225				

Brushtech Industrial

Internal finishing



Double wire cable and loop.

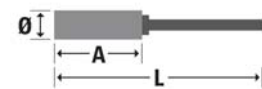

Ø	mm		pcs.	steel wire crimped	RRP	brass crimped	RRP	stainless crimped	RRP
	A	L		Order-No.	€	Order-No.	€	Order-No.	€
4	100	300	20			0003-816 504		0003-816 304	
4	100	320	20	0003-816 204					
5	100	300	20			0003-816 505		0003-816 305	
5	100	320	20	0003-816 205					
6	100	320	20	0003-816 206				0003-816 306	
8	100	300	20			0003-816 506		0003-816 308	
8	100	320	20	0003-816 208					
10	100	300	20			0003-816 510			
10	100	320	20	0003-816 210				0003-816 310	
12	100	300	20	0003-816 212				0003-816 312	
12	100	320	20			0003-816 512			
15	100	300	20	0002-816 215		0002-816 515		0002-816 315	
18	100	300	20	0002-816 218		0002-816 518		0002-816 318	
20	100	300	20	0002-816 220		0002-816 520		0002-816 320	
25	100	300	20	0002-816 225		0002-816 525		0002-816 325	

Ø	mm		pcs.	nylon	RRP	Order-No.	€	Order-No.	€
	A	L		Order-No.	€				
4	100	300	20	0003-816 804					
5	100	300	20	0003-816 805					
6	100	300	20	0003-816 806					
8	100	300	20	0003-816 808					
10	100	300	20	0003-816 810					
12	100	300	20	0003-816 812					
15	100	300	20	0003-816 815					
18	100	300	20	0003-816 818					
20	100	300	20	0003-816 820					
25	100	300	20	0003-816 825					

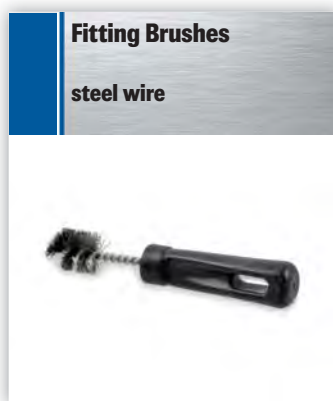

To clean the inside of tubes and solder fittings made of copper or red brass.

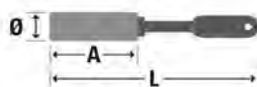

Ø	mm		pcs.	0,20 steel wire	RRP	Order-No.	€	Order-No.	€
	A	L		Order-No.	€				
13	25	160	12	0003-075 252					
16	25	160	12	0003-075 253					
19	28	160	12	0003-075 254					
23	25	160	12	0003-075 255					

Brushtechonology Industrial Internal finishing

Battery Terminal Brush steel wire



To clean batteries (pole and clamp cleaning).



mm				steel wire crimped	RRP				
Ø	T	L	pcs.	Order-No.	€	Order-No.	€	Order-No.	€
15/ 25	65	120	12	0008-493 100					

Stove Pipe Cleaners crimped wire



With a flexible, galvanised wire handle.

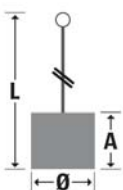

mm				0,30 crimped	RRP				
Ø	A	L	pcs.	Order-No.	€	Order-No.	€	Order-No.	€
125	120	2000	10	0002-824 213					
125	120	3000	10	0002-825 213					
140	120	3000	10	0002-825 214					
160	120	3000	10	0002-825 216					

Brushtechology Industrial
Internal finishing



Brushtechology Industrial
ATB® – Advanced Technology Brush System



PRODUCT INTRODUCTION

ATB®

Extremely long life

- Lower piece cost for the deburring process
- High safety
- Reduced set-up costs and down times

Flexible long life

- Dimensionally stable, also with longer trim lengths and high rotational speeds

High-tech filaments

- High density of abrasive grit for powerful deburring
- Can be used with coolants

Extremely high fill density with even surface

Shorter operating times and very even edge blending. Particularly suitable for deburring of:

- machined surfaces
- sintered products
- stampings and mouldings
- diecasted parts
- cylinder heads
- motor units
- hydraulic parts
- pneumatic parts

of different geometries and materials

Extremely high fill density

The new ATB disc brushes have fill density which is 4 times higher than other disc brushes manufactured according to the conventional method (punched)! By this the brush life is increased many times over, with quicker processing times and better and more efficient results at the same time.

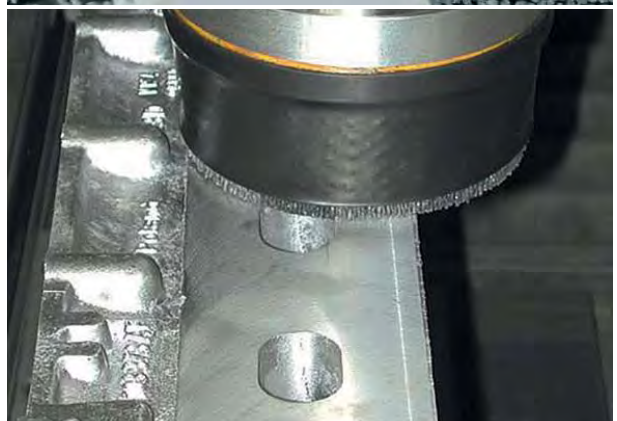
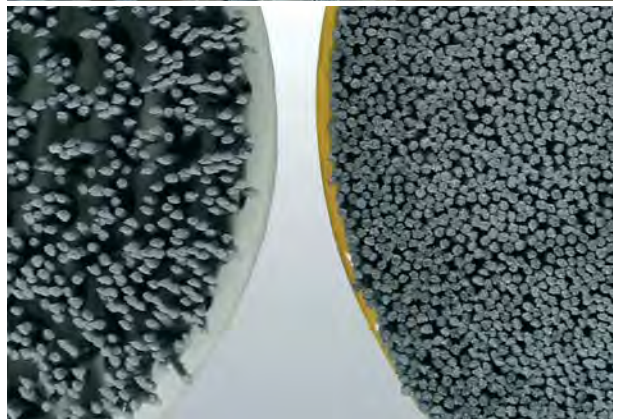

Brushtech Industrial ATB® – Advanced Technology Brush System

ATB brush with maximum fill density compatible with clamping fixture



mm		INDEX				grit 80	grit 120
Total Ø	Trim length T	Bore diameter	for clamping fixture	à	Order-No.	Order-No.	
50	35	16 Hexagonal	K = fixture with shank	1	6701-604 912	5411-604 912	
76	35	16 Hexagonal	L = fixture with shank	1	3111-604 913	9841-604 913	
85	35	16 Hexagonal	J = fixture with shank	1	6201-604 914	1601-604 914	
106	35	16 Hexagonal	H = fixture with shank	1	3101-604 914	3221-604 914	

mm		INDEX				grit 180	grit 320
Total Ø	Trim length T	Bore diameter	for clamping fixture	à	Order-No.	Order-No.	
50	35	16 Hexagonal	K = fixture with shank	1	5431-604 912	5441-604 912	
76	35	16 Hexagonal	L = fixture with shank	1	3311-604 913	3151-604 913	
85	35	16 Hexagonal	J = fixture with shank	1	2211-604 914	6231-604 914	
106	35	16 Hexagonal	H = fixture with shank	1	3321-604 914	3401-604 914	

Price on request.

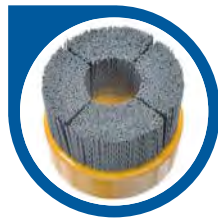

For deburring applications of components with various materials just as e.g. steel, aluminum and cast iron.

ATB brush with max. fill density for tool holders



mm		INDEX				grit 80	grit 120
Total Ø	Trim length T	Bore diameter	for clamping fixture	pcs.	Order-No.	Order-No.	
125	40	18 + Driv.hole	C = fixture for HSK/SK	1	3101-604 916	3201-604 916	
150	40	18 + Driv.hole	D = fixture for HSK/SK	1	3111-604 916	3211-604 916	
175	40	18 + Driv.hole	E = fixture for HSK/SK	1	3131-604 916	3231-604 916	
200	40	18 + Driv.hole	F = fixture for HSK/SK	1	8411-604 918	4021-604 918	
250	38	18 + Driv.hole	G = fixture for HSK/SK	1	6511-604 919	6171-604 916	

mm		INDEX				grit 180	grit 320
Total Ø	Trim length T	Bore diameter	for clamping fixture	pcs.	Order-No.	Order-No.	
125	40	18 + Driv.hole	C = fixture for HSK/SK	1	3311-604 916	3401-604 916	
150	40	18 + Driv.hole	D = fixture for HSK/SK	1	4341-604 916	3411-604 916	
175	40	18 + Driv.hole	E = fixture for HSK/SK	1	3341-604 916	3431-604 916	
200	40	18 + Driv.hole	F = fixture for HSK/SK	1	5901-604 918		
250	38	18 + Driv.hole	G = fixture for HSK/SK	1	2401-604 919		

Price on request.



For deburring applications of sealing and contact surfaces as well as functional areas for a wide range of components. Use on stationary machines with cooling lubricant, water or oil is recommended.

Brusstechnology Industrial

ATB® – Advanced Technology Brush System



ATB brush with fixed clamping fixture.

For ATB brushes with diameter:

		INDEX K Ø 50 mm	INDEX L Ø 76 mm	INDEX J Ø 85 mm	INDEX H Ø 106 mm
clamping fixture	pcs.	Order-No.	Order-No.	Order-No.	Order-No.
with shank Ø 12 mm and clamping DIN 6535 HB	1	5002-075 000	3642-075 000	9602-075 000	3652-075 000

		INDEX C Ø 125 mm	INDEX D Ø 150 mm	INDEX E Ø 175 mm	INDEX F Ø 200 mm	INDEX G Ø 250 mm
clamping fixture	pcs.	Order-No.	Order-No.	Order-No.	Order-No.	Order-No.
for inclusion on clamping cones HSK/SK	1	3602-075 000	3612-075 000	3622-075 000	3692-075 000	1922-075 000

Price on request.

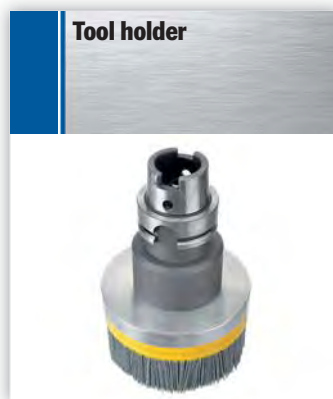

ATB-brush with assembled HSK-cone.

Tool Holders	for INDEX	pcs.	Order-No.
HSK – A63, DIN 69893A	C, D, E, F, G	1	3603-604 000
HSK – A100, DIN 69893A	C, D, E, F, G	1	3633-604 000
SK – 40, DIN 69871	C, D, E, F, G	1	3613-604 000
Weldon surface with shank Ø 12 mm, HSK – 63 DIN 69893A	H, J, K, L	1	4933-604 000
Weldon surface with shank Ø 12 mm, HSK – 100 DIN 69893A	H, J, K, L	1	6303-604 000

Price on request.

Brushtech Industrial ATB® – Advanced Technology Brush System

ATB brush with max. fill density for shell mill mount



For deburring applications of sealing and contact surfaces as well as functional areas for a wide range of components. Use on stationary machines with cooling lubricant, water or oil is recommended. For direct mounting on shell mill holders without need of additional clamping sets / systems.

mm		INDEX			grit 80	grit 120
Brush Ø	Trim length T	Bore diameter	for fixture	pcs.	Order-No.	Order-No.
50	35	Ø 16 +keyways	Direct to shell mill holder	1	6601-604 912	6501-604 912
76	35	Ø 16 +keyways	Direct to shell mill holder	1	6301-604 913	6311-604 913
76	35	Ø 22 +keyways	Direct to shell mill holder	1	5521-604 913	5511-604 913
106	35	Ø 16 +keyways	Direct to shell mill holder	1	5431-604 914	5511-604 914
106	35	Ø 22 +keyways	Direct to shell mill holder	1	5501-604 914	5791-604 914
106	35	Ø 27 +keyways	Direct to shell mill holder	1	5601-604 914	5611-604 914
125	35	Ø 16 +keyways	Direct to shell mill holder	1	6751-604 916	6801-604 916
125	35	Ø 22 +keyways	Direct to shell mill holder	1	6721-604 916	6821-604 916
125	35	Ø 27 +keyways	Direct to shell mill holder	1	6761-604 916	6811-604 916
150	35	Ø 22 +keyways	Direct to shell mill holder	1	6771-604 916	6841-604 916
150	35	Ø 27 +keyways	Direct to shell mill holder	1	6781-604 916	6831-604 916

mm		INDEX			grit 180
Brush Ø	Trim length T	Bore diameter	for fixture	pcs.	Order-No.
50	35	Ø 16 +keyways	Direct to shell mill holder	1	6401-604 912
76	35	Ø 16 +keyways	Direct to shell mill holder	1	6321-604 913
76	35	Ø 22 +keyways	Direct to shell mill holder	1	5501-604 913
106	35	Ø 16 +keyways	Direct to shell mill holder	1	5441-604 914
106	35	Ø 22 +keyways	Direct to shell mill holder	1	5521-604 914
106	35	Ø 27 +keyways	Direct to shell mill holder	1	5621-604 914
125	35	Ø 16 +keyways	Direct to shell mill holder	1	6631-604 916
125	35	Ø 22 +keyways	Direct to shell mill holder	1	6621-604 916
125	35	Ø 27 +keyways	Direct to shell mill holder	1	6641-604 916
150	35	Ø 22 +keyways	Direct to shell mill holder	1	6651-604 916
150	35	Ø 27 +keyways	Direct to shell mill holder	1	6661-604 916

Price on request.

ATB brush TURBO-Line



Brushes for continuous deburring lines with planetary heads. Application: flat parts produced and deburred in punching, lasered, fine blanking or forming technology.

The Turbo-style sections of filaments can be angled to the right or to the left in a defined angle. Depending on the direction of rotation, the deburring will be more aggressive and effective or the brush is reaching a surface finish only.

mm		INDEX			grit 80	grit 120
Brush Ø	Trim length T	Bore diameter	material direction	pcs.	Order-No.	Order-No.
150	25	Ø 25/35 + 2 driv.holes	Turbo style-neutral	1	3141-604 916	3241-604 916
150	25	Ø 25/35 + 2 driv.holes	Turbo style-right	1	3181-604 916	3281-604 916
150	25	Ø 25/35 + 2 driv.holes	Turbo style-left	1	3161-604 916	3261-604 916

mm		INDEX			grit 180	grit 320
Brush Ø	Trim length T	Bore diameter	material direction	pcs.	Order-No.	Order-No.
150	25	Ø 25/35 + 2 driv.holes	Turbo style-neutral	1	3351-604 916	3441-604 916
150	25	Ø 25/35 + 2 driv.holes	Turbo style-right	1	3391-604 916	3481-604 916
150	25	Ø 25/35 + 2 driv.holes	Turbo style-left	1	3371-604 916	3461-604 916

Price on request.



Brushtechnology Industrial Novotec

Novotec wheel brushes with fill material novofil®-DR

Features of these brushes include

a single disc and steel flange. Extremely narrow face widths allow for cutting speeds of approximately 15 m/s (oscillating).

Fill material

Novotec wheel brushes are provided with the hardest abrasive grit available: diamond chips. This ensures not only high performance but also prolonged brush life. On request, we can also supply novofil®-BR (abrasive grit: boron nitride).

Filament

Round filaments

Application range

Ceramics

This brush type is designed for structuring cutting edge geometries of ceramic turnplates as well as deburring wheels.

Hard metal tools

- hard metal drills
- milling cutters
- hard metal turnplates
- circular saws

Cutting edge geometries are shaped by means of a defined cutting edge roundness. This prevents the cutting edge from breaking away- during operation at higher cutting speeds and feeds.

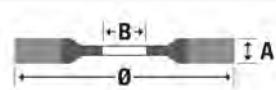

mm		⊙	⌚	📦	grit 240	RRP	grit 400	RRP	grit 600	RRP
Ø	A	B	rpm	pcs.	Order-No.	€	Order-No.	€	Order-No.	€
150	4	20	2800	1	2401-901 924		4001-901 924		6001-901 924	
150	8	20	2800	1	2401-902 924		4001-902 924		6001-902 924	
200	4	20	1400	1	2401-901 926		4001-901 926		6001-901 926	
200	8	20	1400	1	2401-902 926		4001-902 926		6001-902 926	

mm		⊙	⌚	📦	grit 800	RRP				
Ø	A	B	rpm	pcs.	Order-No.	€	Order-No.	€	Order-No.	€
150	4	20	2800	1	1201-901 924					
150	8	20	2800	1	6201-902 924					
200	4	20	1400	1	1911-901 926					
200	8	20	1400	1	6901-902 926					

Price on request.



Heavy-Duty Idler-Rollers Load Runners®

MORE THAN JUST FINISHING WE KEEP THINGS MOVING

Osborn Load Runners® are the ultimate heavy-duty load rail and idler roller solution in the industry, providing precision performance across numerous applications. Load Runners® help reduce your design time and lower overall material handling system costs.



Load Runners® Load Guidance Systems for Precision Handling of Heavy Loads in Tough Environments

When reliability is paramount, combine the high capacity of Load Runners® idler-rollers with long-lasting, rugged Load Rails®, to move your products, people, or process from Point A to Point B.

Load Runners® feature heat-treated specialty steel, precision bearings, a maintenance-free lubrication and seal system, and a global network of sales support and application engineering expertise.

Often the "unsung hero" in the application, idler rollers play a significant role in the overall success of any rail-riding operation. Properly specified, idler rollers optimize line speed and product handling, regardless of material run or machinery used.



Primary Metals



**Oil & Field
Petrochemical**



**Off-Highway
Equipment:
Agriculture,
Construction &
Mining**



**Food &
Pharmaceutical**



Automotive



**Mining &
Aggregate**

FURTHER INFORMATION

If you are involved with product selection please contact the Osborn team.
Phone: +49 (0) 6451 588-0 Email: info@osborn.de

Product information &
CAD-Download available on
www.loadrunners.de



www.loadrunners.de



STRIP BRUSHES 142

BROOMATE® 145

Specials Strip brushes

VERSATILE ALLROUNDER

Strip brushes and aluminum extrusions

Find optimal solutions for your individual application with Osborn strip brushes.

Typical areas of application are e.g.:

- Sealing
- Guiding
- Positioning
- Transporting
- Protecting and shielding
- Skirting and closing of gaps e.g. cable bushing
- Wiping and stripping

You can choose between numerous possibilities from our standard range. Our range includes brushes with nylon (PA6) and galvanized backings either as single unit or with aluminum extrusion in H- (180°) or F- (90°) profile. The aluminium extrusions are excellent in regard to optics and stability.

Osborn nylon strip brushes are supplied in standard length of 3000 mm. Customized solutions or different length can be supplied on request under consideration of our minimum order quantities.



Horse hair filling

In addition our standard range offers strip brushes with high-grade pure horse hair filling. They are an effective sealing for any kind of doors, gates and windows of buildings as they ensure protection against coldness, draught, insects, dust and noise.

A positive side effect is that you will save energy with our durable, UV-resistant and flexible horse hair that ensures an optimal isolation and sealing effect.

Our range offers standard length of 1000 and 2000 mm including our 180° aluminum extrusion ex stock.



Specials Strip brushes

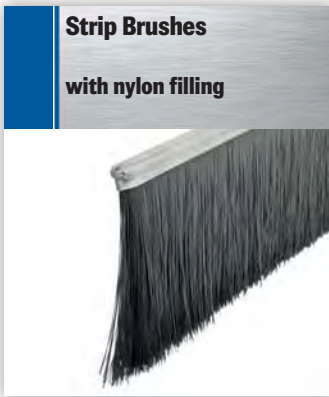

Strip brushes incl. aluminum extrusion
h-profile 180°/F-profile 90° with PA6
straight, black for innovative brush-based
solutions in various industrial applications.

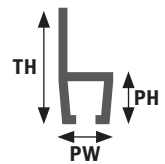
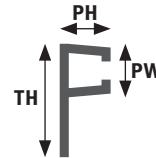
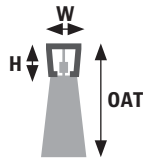

Strip brushes type A:

mm	mm	mm	mm	mm	RRP
OAT	L	W	H	PA6 Ø	Order-No. €/m
15	3000	2,5	2,7	0,15	0904-905 822

Strip brushes type B:

mm	mm	mm	mm	mm	RRP
OAT	L	W	H	PA6 Ø	Order-No. €/m
19	3000	4	3,7	0,15	0924-905 822
45	3000	4	3,7	0,15	0904-905 825

Strip brushes type E:

mm	mm	mm	mm	mm	RRP
OAT	L	W	H	PA6 Ø	Order-No. €/m
25	3000	5,1	6,3	0,20	0924-905 823
32	3000	5,1	6,3	0,20	0904-905 824
45	3000	5,1	6,3	0,20	0914-905 825

Strip brushes type K:

mm	mm	mm	mm	mm	RRP
OAT	L	W	H	PA6 Ø	Order-No. €/m
50	3000	6,6	7,5	0,20	0924-905 825
75	3000	6,6	7,5	0,30	0904-905 837

Strip brushes type F:

mm	mm	mm	mm	mm	RRP
OAT	L	W	H	PA6 Ø	Order-No. €/m
60	3000	7,8	8,7	0,50	0904-905 856
75	3000	7,8	8,7	0,30	0904-905 847
115	3000	7,8	8,7	0,50	0904-905 859
60	3000	7,8	8,7	0,90	0904-905 896

Strip brushes type L:

mm	mm	mm	mm	mm	RRP
OAT	L	W	H	PA6 Ø	Order-No. €/m
230	3000	11,4	12,5	0,90	0904-905 899
150	3000	11,4	12,5	0,60	0904-905 869

Aluminium extrusion type A:

mm	mm	mm	mm	RRP
Profile	TH	PW	PH	Order-No. €/m
180°	13,5	4,4	4	0114-906 000
90°	14	5,2	5,7	0214-906 000

Aluminium extrusion type B:

mm	mm	mm	mm	RRP
Profile	TH	PW	PH	Order-No. €/m
180°	15	7,3	7	0124-906 000
90°	16	7,3	7	0224-906 000

Aluminium extrusion type E:

mm	mm	mm	mm	RRP
Profile	TH	PW	PH	Order-No. €/m
180°	27	8,2	10	0144-906 000
90°	27	9	10	0244-906 000

Aluminium extrusion type K:

mm	mm	mm	mm	RRP
Profile	TH	PW	PH	Order-No. €/m
180°	30	10	12	0154-906 000
90°	37	12	12	0254-906 000

Aluminium extrusion type F:

mm	mm	mm	mm	RRP
Profile	TH	PW	PH	Order-No. €/m
180°	33	12	13	0164-906 000
90°	41	13	14	0264-906 000

Aluminium extrusion type L:

mm	mm	mm	mm	RRP
Profile	TH	PW	PH	Order-No. €/m
180°	68	18	17	0174-906 000
90°	62	17	18	0274-906 000

* Available in lengths of 1000, 2000 or 3000 mm

* Customized solutions and special lengths are available on request under consideration of our MOQ

Specials

Strip brushes

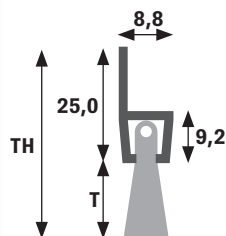

Strip brushes incl. aluminum extrusion h-profile 180° with horse hair filling for an effective sealing of doors, gates and windows.

mm	mm	mm			RRP
T	L	TH	pcs.	Order-No.	€/piece
15	1000	40	10	0004-906 962	
15	2000	40	10	0034-906 962	
25	1000	50	10	0004-906 963	
25	2000	50	10	0034-906 963	
35	1000	60	10	0004-906 954	
35	2000	60	10	0034-906 954	
45	1000	70	10	0004-906 955	
45	2000	70	10	0034-906 955	

* Backing tape strip brush 5x5 mm, galvanized steel



BROOM FOR FARMING AND INDUSTRIAL

In production facilities, agricultural premises or recycling and waste-management sites there are a lot of areas which need to be kept clean at any time. Osborn has developed a sweeping solution that achieves this result easily, professionally and with low cost. Our broom consists of high quality single strip brushes which are assembled under a solid 5 mm galvanized hood.

The Osborn Broomate® can be attached to a big number of industrial or agricultural vehicles and cleans all sorts of heavy debris, but also liquids.

There are no rotating or electrical parts. Just mount the broom to your vehicle in no time and start sweeping.



The galvanized steel cover that makes it easy to remove the brushes is available in different widths.

Broomate® Model	Minimate	Midimate	Maximate	Megamate	Quad/ Lawnmower
Article number	0004APR120	0004APR180	0004APR240	0004APR300	0014APR12Q
Width (A)	1200 mm	1800 mm	2400 mm	3000 mm	1200 mm
Depth (B)	560 mm	706 mm	706 mm	706 mm	460 mm
Height (C)	540 mm	540 mm	540 mm	540 mm	350 mm
Width forklift-adapter (D)	180 mm (170) WP 210	180 mm (170) WP 210	180 mm (170) WP 210	180 mm (170) WP 210	depending on model
Length forklift-adapter (E)	1060 mm	1060 mm	1060 mm	1060 mm	
Height forklift-adapter (F)	80 mm (75)	80 mm (75)	80 mm (75)	80 mm (75)	
Dimension between forklift-adapter (G)	656 mm	656 mm	656 mm	656 mm	
Steel thickness	5 mm	5 mm	5 mm	5 mm	3 mm
Canopy finishing	galvanized	galvanized	galvanized	galvanized	black lacquer
No. of brush strips	8	11	11	11	7
Weight	95 kg	157 kg	260 kg	337 kg	42 kg
Strip filaments/colour	poly red	poly red	poly red	poly red	poly red
Adapter & options					
Forklift-adapter (170x70) (optional)	•	•	•	•	•
Forklift-adapter wide pocket (210x70)	○	○	○	○	○
Forklift & shovel/loader adapter	○	○	○	○	○
Forklift & skid steer adapter	○	○	○	○	○
Forklift & Euro frame adapter	○	○	○	○	○
Forklift & 3 point adapter	○	○	○	○	○
Storage support legs	•	•	•	•	•
Edge marker kit	○	○	○	○	○
Special adapters	on request	on request	on request	on request	on request
Packaging	•	•	•	•	•
Brush replacement kit	Unit	Unit	Unit	Unit	Unit
0004APR034 set of 11 strip brushes (580x285)	–	–	1	2	depending on model
0004APR017 set of 8 strip brushes (1200x285)	1	–	–	–	
0004APR013 set of 11 strip brushes (1820x285)	–	1	1	1	
Weight	20 kg	41,25 kg	55 kg	68,75 kg	

● Included ○ Optional

BROOMATE® ADVANTAGES

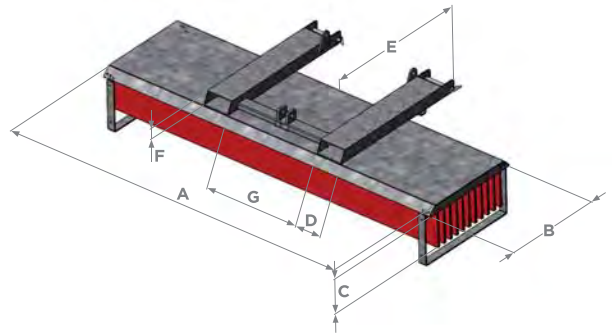

Maintenance free

- Simple and cost effective cleaning solution.
- No hydraulics, no motors, no rotating or electrical parts.
- Easy to clean simply with water or high-pressure washer.

Robust

- 5 mm galvanized steel hood and fork-shoes and protective end-shield.

Versatile

- Excellent cleaning capabilities suitable for heavy debris and dirt like gravel, sand, slurry and light snow, as well as for liquids.
- Bi-directional – sweep forward or in reverse.

Variable Mounting

- Quick and easy mounting on almost any vehicle using optional adapters (extensive range available).

Long service life

- Strip brushes last up to 1000 kilometers.

Environmentally friendly

- All parts can be recycled.
- No need for motor oil, fuel or electric consumption.

Easy replacement

- Strip brushes can be replaced in an instant.
- Simply slide-out and slide-in.

Easy storage

- Supporting frame prevents stripbrushes from bending in storage.

Safety First

- No rotating parts, chains or motors.
- No noise, no dust.



MORE
INFORMATION

Scan in QR code and view product video, or download catalogue.



www.broomate.com

Specials Broomate®





Index

Order-No.	Page	Order-No.	Page	Order-No.	Page	Order-No.	Page	Order-No.	Page
0001-102 006	83	0002-056 316	127	0002-506 132	42, 59	0002-544 361	110	0002-621 151	23
0001-102 016	83	0002-056 317	127	0002-506 141	42, 59	0002-554 141	110	0002-621 351	23
0001-102 095	83	0002-056 318	127	0002-506 142	42, 59	0002-554 161	110	0002-622 131	33
0001-104 924	84	0002-056 331	127	0002-506 161	42, 59	0002-554 341	110	0002-622 151	33
0001-110 114	85	0002-056 332	127	0002-506 332	42, 60	0002-554 361	110	0002-622 331	33
0001-120 097	85	0002-056 333	127	0002-506 341	42, 60	0002-566 141	110	0002-622 351	33
0001-122 096	85	0002-056 334	127	0002-506 342	42, 60	0002-566 161	110	0002-623 131	33
0001-150 592	77	0002-056 335	127	0002-506 343	42, 60	0002-566 361	110	0002-623 151	33
0001-150 593	77	0002-056 336	127	0002-506 361	42, 60	0002-576 141	110	0002-623 331	33
0001-150 594	77	0002-056 337	127	0002-506 362	42, 60	0002-576 145	113	0002-623 351	33
0001-150 595	77	0002-056 338	127	0002-506 363	42, 60	0002-576 161	110	0002-626 061	24
0001-151 132	77	0002-501 132	42, 59	0002-506 542	42, 60	0002-576 195	113	0002-626 251	24
0001-151 133	77	0002-501 142	42, 59	0002-507 142	42, 59	0002-576 341	110	0002-626 305	24
0001-151 134	77	0002-501 143	42, 59	0002-507 162	42, 59	0002-576 345	113	0002-626 311	24
0001-151 135	77	0002-502 132	42, 59	0002-507 342	42, 60	0002-576 361	110	0002-626 505	24
0001-151 332	77	0002-502 141	42, 59	0002-507 362	42, 60	0002-576 395	113	0002-626 650	24
0001-151 333	77	0002-502 142	42, 59	0002-507 542	42, 60	0002-576 906	113	0002-626 651	24
0001-151 334	77	0002-502 143	42, 59	0002-509 142	50, 66	0002-576 916	113	0002-630 304	63
0001-151 335	77	0002-502 332	42, 60	0002-509 143	50, 66	0002-576 926	113	0002-630 305	63
0001-151 392	77	0002-502 333	42, 60	0002-509 144	50, 66	0002-587 161	110	0002-630 310	63
0001-151 393	77	0002-502 341	42, 60	0002-509 162	50, 66	0002-587 162	111	0002-630 311	63
0001-151 394	77	0002-502 342	42, 60	0002-509 163	50, 66	0002-587 341	110	0002-630 316	63
0001-151 395	77	0002-502 343	42, 60	0002-509 164	50, 66	0002-608 131	27	0002-630 317	63
0001-152 022	77	0002-502 542	42, 60	0002-509 165	66	0002-608 133	29	0002-630 328	63
0001-152 023	77	0002-503 132	42, 59	0002-509 167	66	0002-608 134	29	0002-630 334	63
0001-152 024	77	0002-503 142	42, 59	0002-509 192	50, 66	0002-608 135	29	0002-630 335	63
0001-152 025	77	0002-503 143	42, 59	0002-509 193	50, 66	0002-608 151	27	0002-630 340	63
0001-152 132	77	0002-503 331	42, 60	0002-509 194	50, 66	0002-608 153	29	0002-630 341	63
0001-152 133	77	0002-503 332	42, 60	0002-509 342	50, 66	0002-608 154	29	0002-631 131	23
0001-152 134	77	0002-503 333	42, 60	0002-509 343	50, 66	0002-608 155	29	0002-631 151	23
0001-152 135	77	0002-503 341	42, 60	0002-509 344	50, 116	0002-608 183	29	0002-631 331	23
0001-152 332	77	0002-503 342	42, 60	0002-509 348	116	0002-608 184	29	0002-631 351	23
0001-152 333	77	0002-503 343	42, 60	0002-509 362	50, 66	0002-608 185	29	0002-632 131	33
0001-152 334	77	0002-503 542	42, 60	0002-509 363	50, 66	0002-608 331	27	0002-632 151	33
0001-152 335	77	0002-504 132	42, 59	0002-509 364	50, 66	0002-608 333	29	0002-632 331	33
0001-158 522	77	0002-504 141	42, 59	0002-509 448	116	0002-608 334	29	0002-632 351	33
0001-158 523	77	0002-504 142	42, 59	0002-509 478	116	0002-608 351	27	0002-641 131	23
0001-158 524	77	0002-504 143	42, 59	0002-509 498	116	0002-608 353	29	0002-641 151	23
0001-158 525	77	0002-504 161	42, 59	0002-509 562	50, 66	0002-608 354	29	0002-641 181	23
0001-179 097	82	0002-504 162	42, 59	0002-509 563	50, 66	0002-611 131	23	0002-641 351	23
0001-179 297	82	0002-504 163	42, 59	0002-509 564	50, 66	0002-611 151	23	0002-653 131	23
0001-261 173	83	0002-504 332	42, 60	0002-509 908	116	0002-613 141	30	0002-653 151	23
0001-401 912	54	0002-504 341	42, 60	0002-511 161	110	0002-613 142	30	0002-653 181	23
0001-432 603	76	0002-504 342	42, 60	0002-512 061	34	0002-613 143	30	0002-653 351	23
0001-432 604	76	0002-504 343	42, 60	0002-512 062	34	0002-613 144	30	0002-664 131	109
0001-432 613	76	0002-504 361	42, 60	0002-512 161	34	0002-613 145	30	0002-664 151	109
0001-432 614	76	0002-504 362	42, 60	0002-512 162	34	0002-613 146	30	0002-664 152	109
0001-432 623	76	0002-504 363	42, 60	0002-512 342	34	0002-613 161	30	0002-664 181	109
0001-432 624	76	0002-504 542	42, 60	0002-512 361	34	0002-613 162	30	0002-676 131	109
0002-056 011	127	0002-505 132	42, 59	0002-512 362	34	0002-613 163	30	0002-676 151	109
0002-056 012	127	0002-505 141	42, 59	0002-514 161	34	0002-613 164	30	0002-676 181	109
0002-056 013	127	0002-505 142	42, 59	0002-514 341	34	0002-613 165	30	0002-686 131	109
0002-056 014	127	0002-505 161	42, 59	0002-514 361	34	0002-613 166	30	0002-686 151	109
0002-056 015	127	0002-505 162	42, 59	0002-522 141	110	0002-613 193	30	0002-686 181	109
0002-056 016	127	0002-505 332	42, 60	0002-522 161	110	0002-613 194	30	0002-808 100	126
0002-056 017	127	0002-505 341	42, 60	0002-522 341	110	0002-613 195	30	0002-808 125	125
0002-056 018	127	0002-505 342	42, 60	0002-522 361	110	0002-613 196	30	0002-808 130	125
0002-056 311	127	0002-505 343	42, 60	0002-532 161	110	0002-613 361	30	0002-808 132	125
0002-056 312	127	0002-505 361	42, 60	0002-532 361	110	0002-613 362	30	0002-808 135	125
0002-056 313	127	0002-505 362	42, 60	0002-544 141	110	0002-613 363	30	0002-808 136	125
0002-056 314	127	0002-505 363	42, 60	0002-544 161	110	0002-613 364	30	0002-808 138	125
0002-056 315	127	0002-505 542	42, 60	0002-544 341	110	0002-621 131	23	0002-808 140	125

Index

Order-No.	Page	Order-No.	Page	Order-No.	Page	Order-No.	Page	Order-No.	Page
0002-808 144	125	0003-056 418	127	0003-810 150	126	0008-600 221	43	0034-906 954	144
0002-808 150	125	0003-056 425	127	0003-810 157	126	0008-600 321	43	0034-906 955	144
0002-808 163	126	0003-056 427	127	0003-810 163	126	0008-600 361	48	0034-906 962	144
0002-808 175	126	0003-056 428	127	0003-810 169	126	0008-600 411	43	0034-906 963	144
0002-812 215	125	0003-056 429	127	0003-810 175	126	0008-600 421	43	0042-576 165	113
0002-812 218	125	0003-056 432	127	0003-810 182	126	0008-600 422	43	0042-576 175	113
0002-812 220	125	0003-056 435	127	0003-815 210	125	0008-600 432	43	0042-576 365	113
0002-815 212	125	0003-056 436	127	0003-816 204	130	0008-600 511	43	0042-576 375	113
0002-815 214	125	0003-056 438	127	0003-816 205	130	0008-600 521	43	0043-003 010	61
0002-816 215	130	0003-056 441	127	0003-816 206	130	0008-600 522	43	0043-003 015	61
0002-816 218	130	0003-056 442	127	0003-816 208	130	0008-600 531	43	0043-004 015	61
0002-816 220	130	0003-056 444	127	0003-816 210	130	0008-600 811	48	0043-004 020	61
0002-816 225	130	0003-056 447	127	0003-816 212	130	0008-600 821	48	0043-005 015	61
0002-816 315	130	0003-056 450	127	0003-816 304	130	0008-600 832	48	0043-005 020	61
0002-816 318	130	0003-075 064	117	0003-816 305	130	0008-600 911	48	0043-005 030	61
0002-816 320	130	0003-075 065	117	0003-816 306	130	0008-600 921	48	0043-006 020	61
0002-816 325	130	0003-075 066	117	0003-816 308	130	0008-852 002	128	0043-006 030	61
0002-816 515	130	0003-075 067	117	0003-816 310	130	0008-852 003	128	0043-006 040	61
0002-816 518	130	0003-075 068	117	0003-816 312	130	0008-852 004	128	0043-006 050	61
0002-816 520	130	0003-075 069	117	0003-816 504	130	0008-852 005	128	0043-008 030	61
0002-816 525	130	0003-075 070	117	0003-816 505	130	0008-852 006	128	0043-008 040	61
0002-819 110	126	0003-075 071	117	0003-816 506	130	0008-852 007	128	0043-008 050	61
0002-824 213	131	0003-075 073	117	0003-816 508	130	0008-852 008	128	0043-010 100	71
0002-825 213	131	0003-075 252	80, 130	0003-816 510	130	0008-852 009	128	0043-160 050	106
0002-825 214	131	0003-075 253	80, 130	0003-816 512	130	0008-852 010	128	0063-003 010	61
0002-825 216	131	0003-075 254	80, 130	0003-816 804	130	0008-852 012	128	0063-003 015	61
0002-892 215	81, 129	0003-075 255	80, 130	0003-816 805	130	0008-852 015	128	0063-004 015	61
0002-892 220	81, 129	0003-086 102	86	0003-816 806	130	0008-852 017	128	0063-004 020	61
0002-892 225	81, 129	0003-086 103	86	0003-816 808	130	0008-852 019	128	0063-004 030	61
0002-911 941	45	0003-086 104	86	0003-816 810	130	0008-852 022	128	0063-005 015	61
0002-911 951	45	0003-086 105	86	0003-816 812	130	0008-852 025	128	0063-005 020	61
0002-921 874	26	0003-102 950	84	0003-816 815	130	0008-852 802	128	0063-005 030	61
0002-921 875	26	0003-102 960	84	0003-816 818	130	0008-852 803	128	0063-006 020	61
0002-921 876	26	0003-102 990	84	0003-816 820	130	0008-852 804	128	0063-006 030	61
0002-921 889	26	0003-133 573	79	0003-816 825	130	0008-852 805	128	0063-006 040	61
0002-930 821	49	0003-140 101	81	0003-999 026	85	0008-852 806	128	0063-006 050	61
0002-930 902	52	0003-140 102	81	0003-999 027	85	0008-852 807	128	0063-008 030	61
0002-930 907	52	0003-162 133	78	0004-000 127	56	0008-852 808	128	0063-008 040	61
0002-930 912	52	0003-162 333	78	0004-102 925	84	0008-852 809	128	0063-008 050	61
0003-000 001	84	0003-165 584	78	0004-401 052	54	0008-852 810	128	0063-010 100	71
0003-000 100	56	0003-165 964	78	0004-401 132	54	0008-852 812	128	0063-160 050	106
0003-000 130	56	0003-509 141	50, 66	0004-401 942	54	0008-852 815	128	0063-404 020	62
0003-000 222	35	0003-509 149	65	0004-509 302	67	0008-852 817	128	0063-404 030	62
0003-000 223	35, 117	0003-509 161	50, 66	0004-906 954	144	0008-852 819	128	0063-405 020	62
0003-000 242	35, 117	0003-509 169	65	0004-906 955	144	0008-852 822	128	0063-405 030	62
0003-000 243	35, 117	0003-509 191	50, 66	0004-906 962	144	0008-852 825	128	0063-405 040	62
0003-000 244	35, 117	0003-509 341	50, 66	0004-906 963	144	0011-261 173	83	0063-406 030	62
0003-056 010	127	0003-509 349	65	0008-432 573	79	0011-401 912	54	0063-406 040	62
0003-056 306	127	0003-509 361	50, 66	0008-447 573	75	0014-509 102	67	0063-406 050	62
0003-056 307	127	0003-509 369	65	0008-447 574	75	0014-509 304	67	0063-408 040	62
0003-056 308	127	0003-509 561	50, 66	0008-462 091	75	0018-852 002	128	0063-408 050	62
0003-056 310	127	0003-515 827	110	0008-462 133	75	0018-852 003	128	0063-410 100	71
0003-056 326	127	0003-600 211	43	0008-462 134	75	0018-852 802	128	0074-509 301	67
0003-056 327	127	0003-600 311	43	0008-462 291	75	0018-852 803	128	0083-003 010	61
0003-056 328	127	0003-810 100	126	0008-462 391	75	0023-179 197	82	0083-003 015	61
0003-056 330	127	0003-810 125	126	0008-462 591	75	0023-600 851	48	0083-004 015	61
0003-056 400	127	0003-810 128	126	0008-493 100	80, 131	0023-600 951	48	0083-004 020	61
0003-056 403	127	0003-810 130	126	0008-509 161	51	0024-509 100	67	0083-004 030	61
0003-056 406	127	0003-810 132	126	0008-509 162	51	0024-509 101	67	0083-005 015	61
0003-056 409	127	0003-810 138	126	0008-509 163	51	0024-509 102	67	0083-005 020	61
0003-056 412	127	0003-810 140	126	0008-509 164	51	0024-509 103	67	0083-005 030	61
0003-056 415	127	0003-810 144	126	0008-509 363	51	0024-509 111	67	0083-006 020	61

Index

Order-No.	Page	Order-No.	Page	Order-No.	Page	Order-No.	Page	Order-No.	Page
0083-006 030	61	0103-075 325	118	0182-600 591	46	0402-631 151	23	0904-905 896	143
0083-006 040	61	0114-906 000	143	0182-600 891	49	0402-631 331	23	0904-905 899	143
0083-006 050	61	0123-003 010	61	0182-600 991	49	0402-631 351	23	0908-507 061	44
0083-008 030	61	0123-003 015	61	0183-003 010	61	0442-514 361	34	0914-905 825	143
0083-008 040	61	0123-004 015	61	0183-003 015	61	0442-608 351	27	0924-905 822	143
0083-008 050	61	0123-004 020	61	0183-004 015	61	0442-608 353	29	0924-905 823	143
0083-010 100	71	0123-004 030	61	0183-004 020	61	0442-608 354	29	0924-905 825	143
0083-160 050	106	0123-005 015	61	0183-005 015	61	0442-613 361	30	1003-086 438	86
0083-304 020	62	0123-005 020	61	0183-005 020	61	0442-613 362	30	1003-086 450	86
0083-304 030	62	0123-005 030	61	0183-005 030	61	0442-613 363	30	1004-608 151	47
0083-305 030	62	0123-006 020	61	0183-006 020	61	0442-613 364	30	1103-819 110	126
0083-305 040	62	0123-006 030	61	0183-006 030	61	0442-622 351	33	1132-819 110	126
0083-306 030	62	0123-006 040	61	0183-006 040	61	0442-632 351	33	1201-901 924	138
0083-306 050	62	0123-006 050	61	0183-006 050	61	0802-600 491	46	1202-509 912	53
0083-308 050	62	0123-008 030	61	0183-008 030	61	0802-600 591	46	1202-509 913	53
0083-310 100	71	0123-008 040	61	0183-008 040	61	0802-600 891	49	1202-509 914	53
0083-404 020	62	0123-008 050	61	0183-008 050	61	0802-600 991	49	1202-631 131	25
0083-404 030	62	0123-010 100	71	0183-010 100	71	0802-608 133	29	1202-631 151	25
0083-405 020	62	0123-160 050	106	0183-310 100	71	0802-608 134	29	1202-653 131	25
0083-405 030	62	0123-410 100	71	0183-410 100	71	0802-608 135	29	1202-653 151	25
0083-405 040	62	0124-509 101	67	0202-611 131	41, 59	0802-608 153	29	1203-300 003	93, 104
0083-406 030	62	0124-509 103	67	0202-611 151	41, 59	0802-608 154	29	1203-600 000	91
0083-406 040	62	0124-509 111	67	0202-611 351	41, 59	0802-608 155	29	1203-600 001	92
0083-406 050	62	0124-509 303	67	0214-906 000	143	0802-608 183	29	1203-600 002	92
0083-408 040	62	0124-906 000	143	0224-509 101	67	0802-608 184	29	1212-631 131	25
0083-408 050	62	0144-906 000	143	0224-906 000	143	0802-608 185	29	1212-631 151	25
0083-410 100	71	0153-003 010	61	0243-003 010	61	0802-613 142	30	1213-300 003	93, 104
0088-600 221	43	0153-003 015	61	0243-003 015	61	0802-613 143	30	1224-509 101	67
0088-600 521	43	0153-004 015	61	0243-004 015	61	0802-613 144	30	1243-404 020	62
0102-512 161	34	0153-004 020	61	0243-004 020	61	0802-613 146	30	1243-404 030	62
0102-512 162	34	0153-005 015	61	0243-005 015	61	0802-613 162	30	1243-405 020	62
0102-512 342	34	0153-005 020	61	0243-005 020	61	0802-613 163	30	1243-405 030	62
0102-512 362	34	0153-005 030	61	0243-005 030	61	0802-613 164	30	1243-405 040	62
0102-608 131	27	0153-006 020	61	0243-006 020	61	0802-613 165	30	1243-406 030	62
0102-608 151	27	0153-006 030	61	0243-006 030	61	0802-613 166	30	1243-406 040	62
0102-608 331	27	0153-006 040	61	0243-006 040	61	0802-613 194	30	1243-406 050	62
0102-608 351	27	0153-006 050	61	0243-006 050	61	0802-613 195	30	1243-408 040	62
0102-613 141	30	0153-008 030	61	0243-008 030	61	0802-613 196	30	1243-408 050	62
0102-613 142	30	0153-008 040	61	0243-008 040	61	0802-613 362	30	1302-753 368	114
0102-613 161	30	0153-008 050	61	0243-008 050	61	0802-613 363	30	1402-631 131	23
0102-613 162	30	0153-304 020	62	0243-010 100	71	0802-632 131	33	1402-631 151	23
0102-622 131	33	0153-304 030	62	0243-304 020	62	0802-632 151	33	1402-631 331	23
0102-622 151	33	0153-305 030	62	0243-304 030	62	0802-632 331	33	1402-631 351	23
0102-622 331	33	0153-305 040	62	0243-305 030	62	0802-632 351	33	1418-600 005	55
0102-622 351	33	0153-306 030	62	0243-305 040	62	0812-509 913	52	1503-015 085	94
0103-075 021	117	0153-306 050	62	0243-306 030	62	0901-151 093	77	1518-600 005	55
0103-075 027	117	0153-308 050	62	0243-306 050	62	0901-151 094	77	1601-604 914	135
0103-075 028	117	0153-404 020	62	0243-308 050	62	0901-151 095	77	1602-608 131	27
0103-075 048	117	0153-404 030	62	0244-906 000	143	0901-151 593	77	1602-608 151	27
0103-075 050	117	0153-405 020	62	0254-906 000	143	0901-151 594	77	1602-608 331	27
0103-075 210	118	0153-405 030	62	0264-906 000	143	0901-151 595	77	1602-613 142	30
0103-075 213	118	0153-405 040	62	0274-906 000	143	0901-152 333	77	1602-613 161	30
0103-075 216	118	0153-406 030	62	0281-307 095	82	0901-152 334	77	1602-613 162	30
0103-075 220	118	0153-406 040	62	0283-310 100	71	0901-152 335	77	1602-613 361	30
0103-075 225	118	0153-406 050	62	0323-304 020	62	0904-905 822	143	1602-613 362	30
0103-075 230	118	0153-408 040	62	0323-304 030	62	0904-905 824	143	1602-622 151	33
0103-075 232	118	0153-408 050	62	0323-305 030	62	0904-905 825	143	1602-632 151	33
0103-075 235	118	0154-906 000	143	0323-305 040	62	0904-905 837	143	1718-509 163	51
0103-075 240	118	0164-906 000	143	0323-306 030	62	0904-905 847	143	1802-509 911	53
0103-075 313	118	0174-906 000	143	0323-306 050	62	0904-905 856	143	1802-509 912	53
0103-075 316	118	0181-110 924	85	0323-308 050	62	0904-905 859	143	1802-509 913	53
0103-075 320	118	0182-600 491	46	0402-631 131	23	0904-905 869	143	1802-509 914	53

Index

Order-No.	Page	Order-No.	Page	Order-No.	Page	Order-No.	Page	Order-No.	Page
1802-607 914	32	2401-902 926	138	4001-901 926	138	6152-631 131	23	7182-600 991	50
1802-608 914	32	2812-522 051	26	4001-902 924	138	6171-604 916	135	7202-611 151	41
1812-509 913	52	2902-632 151	33	4001-902 926	138	6201-604 914	135	7601-306 095	82
1903-080 101	94	2906-026 501	24	4021-604 918	135	6201-902 924	138	7602-743 378	114
1903-080 290	94	3002-504 342	43	4102-921 051	26	6231-604 914	135	7702-921 875	26
1903-100 101	94	3101-604 914	135	4306-026 904	23	6301-604 913	137	7801-401 912	55
1903-100 290	94	3101-604 916	135	4341-604 916	135	6303-604 000	136	7802-509 913	53
1911-901 926	138	3111-604 913	135	4403-022 130	98, 106	6311-604 913	137	7802-600 491	46
1922-075 000	136	3111-604 916	135	4602-626 131	23	6321-604 913	137	7802-600 591	46
2008-512 061	34	3131-604 916	135	4602-626 331	23	6401-604 912	137	7802-600 891	50
2008-512 161	34	3141-604 916	137	4602-743 178	114	6402-608 914	32	7802-600 991	50
2008-608 131	29	3151-604 913	135	4612-626 331	23	6412-608 914	32	7811-401 912	55
2008-608 151	29	3161-604 916	137	4802-622 131	33	6501-604 912	137	7812-509 913	53
2008-608 152	29	3181-604 916	137	4802-622 331	33	6511-604 919	135	8103-800 224	93, 104
2008-608 153	29	3201-604 916	135	4802-703 052	72	6601-604 912	137	8203-100 914	93
2008-608 154	29	3202-509 911	53	4802-703 062	72	6621-604 916	137	8203-100 925	93
2008-608 184	29	3202-509 912	53	4902-613 561	30	6631-604 916	137	8203-100 934	104
2008-613 061	31	3202-509 913	53	4902-613 562	30	6641-604 916	137	8203-100 936	104
2008-613 062	31	3202-509 914	53	4902-613 563	30	6651-604 916	137	8203-100 944	93
2008-613 063	31	3211-604 916	135	4902-626 651	23	6661-604 916	137	8203-100 947	104
2008-613 064	31	3221-604 914	135	4902-631 351	23	6701-604 912	135	8203-150 914	93
2008-613 065	31	3231-604 916	135	4902-653 351	23	6721-604 916	137	8203-150 925	93
2008-613 161	31	3241-604 916	137	4912-613 561	30	6751-604 916	137	8203-150 934	104
2008-613 162	31	3261-604 916	137	4912-613 564	30	6761-604 916	137	8203-150 936	104
2008-613 163	31	3281-604 916	137	4912-631 351	23	6771-604 916	137	8203-150 944	93
2008-613 164	31	3301-462 122	76	4933-604 000	136	6781-604 916	137	8203-150 947	104
2008-613 165	31	3301-462 162	76	5002-075 000	136	6801-604 916	137	8203-200 914	93
2008-631 151	23	3301-462 562	76	5162-507 361	42, 60	6811-604 916	137	8203-200 925	93
2102-576 916	113	3303-140 101	81	5262-613 141	30	6821-604 916	137	8203-200 934	104
2103-000 461	101	3311-604 913	135	5401-401 913	27	6831-604 916	137	8203-200 936	104
2103-002 101	101	3311-604 916	135	5402-921 051	26	6841-604 916	137	8203-200 947	104
2103-002 102	101	3321-604 914	135	5402-921 873	25	6901-902 926	138	8211-201 944	93
2103-005 333	101	3341-604 916	135	5411-401 913	27	6912-613 561	37	8411-604 918	135
2103-007 012	101	3351-604 916	137	5411-604 912	135	6912-613 891	37	8601-411 912	72
2103-080 101	94	3371-604 916	137	5421-401 913	27	6912-622 891	38	8603-600 004	91
2103-080 290	94	3391-604 916	137	5431-604 912	135	6931-401 912	72	8603-600 010	91
2103-100 101	94	3401-604 914	135	5431-604 914	137	6941-401 912	72	8611-411 912	72
2103-100 290	94	3401-604 916	135	5441-604 912	135	6951-401 912	72	8641-411 912	72
2103-100 914	93	3411-604 916	135	5441-604 914	137	6961-401 912	72	8802-753 478	114
2103-100 925	93	3431-604 916	135	5495-560 051	114	7002-504 362	43	8812-607 914	32
2103-100 944	93	3441-604 916	137	5495-560 052	114	7002-505 162	43	9301-614 916	32
2118-631 151	23	3461-604 916	137	5495-560 054	114	7002-505 542	43	9311-614 916	32
2202-631 151	23	3481-604 916	137	5495-560 080	114	7002-507 142	43	9321-614 916	32
2202-631 331	23	3602-075 000	136	5495-560 082	114	7002-507 162	43	9331-614 916	32
2202-631 351	23	3602-632 131	33	5501-604 913	137	7002-507 342	43	9502-626 251	23
2211-604 914	135	3602-632 331	33	5501-604 914	137	7002-507 362	43	9502-626 301	23
2224-509 101	67	3602-632 351	33	5511-604 913	137	7003-507 061	45	9502-626 311	23
2312-607 914	32	3603-604 000	136	5511-604 914	137	7003-600 221	44	9502-626 501	23
2352-512 161	34	3612-075 000	136	5521-604 913	137	7003-600 421	44	9502-626 651	23
2352-512 162	34	3613-604 000	136	5521-604 914	137	7003-600 521	44	9502-664 151	23
2352-512 342	34	3622-075 000	136	5601-604 914	137	7003-600 821	48	9602-075 000	136
2352-512 362	34	3633-604 000	136	5611-604 914	137	7003-600 921	48	9706-026 904	24
2352-608 131	27	3642-075 000	136	5621-604 914	137	7004-608 151	47	9711-104 925	84
2352-608 151	27	3652-075 000	136	5652-613 142	30	7008-509 363	51	9802-026 560	109
2352-608 331	27	3692-075 000	136	5652-613 162	30	7008-600 361	48	9802-026 561	109
2352-608 351	27	3892-608 131	27	5702-509 938	116	7008-600 832	48	9802-026 562	109
2352-622 151	33	3901-411 912	72	5791-604 914	137	7012-611 351	41	9802-026 563	109
2352-622 351	33	3902-613 161	31	5901-604 918	135	7018-600 521	44	9802-026 581	109
2401-604 919	135	3902-613 163	31	6001-901 924	138	7022-506 142	43	9802-026 582	109
2401-901 924	138	3902-613 164	31	6001-901 926	138	7182-600 491	46	9802-026 583	109
2401-901 926	138	3912-613 163	31	6001-902 924	138	7182-600 591	46	9802-921 873	25
2401-902 924	138	4001-901 924	138	6001-902 926	138	7182-600 891	50	9802-921 875	25

Index

Order-No.	Page	Order-No.	Page	Order-No.	Page	Order-No.	Page	Order-No.	Page
9803-523 056	72	9838-036 318	128	9902-543 542	112	9902-576 342	112	9906-015 052	115
9803-523 346	72	9838-036 320	128	9902-543 543	112	9902-576 343	112	9906-015 053	115
9803-630 101	65	9838-036 322	128	9902-543 562	112	9902-576 362	112	9906-015 056	115
9803-630 151	65	9838-036 325	128	9902-543 563	112	9902-576 363	112	9906-015 057	115
9803-630 171	65	9838-036 328	128	9902-544 142	111	9902-576 464	111	9906-015 058	115
9803-630 301	65	9838-036 330	128	9902-544 162	111	9902-586 142	112	9906-015 059	115
9803-630 351	65	9838-036 332	128	9902-544 163	111	9902-586 162	112	9906-015 062	115
9803-630 371	65	9838-036 335	128	9902-544 193	111	9902-586 163	112	9906-015 063	115
9812-921 873	25	9838-036 345	128	9902-544 341	112	9902-586 342	112	9906-015 064	115
9812-921 875	25	9838-036 348	128	9902-544 342	112	9902-586 343	112	9906-015 065	115
9818-036 309	128	9838-036 351	128	9902-544 361	112	9902-586 362	112	9906-015 069	115
9818-036 310	128	9838-036 355	128	9902-544 362	112	9902-586 363	112	9906-015 070	115
9818-036 311	128	9838-036 357	128	9902-544 441	111	9902-587 142	111	9906-015 071	115
9818-036 312	128	9838-036 360	128	9902-544 461	111	9902-587 143	111	9906-015 079	115
9818-036 313	128	9841-604 913	135	9902-544 491	111	9902-587 162	111	9906-015 080	115
9818-036 316	128	9902-511 162	111	9902-553 162	112	9902-587 163	111	9906-015 081	115
9818-036 318	128	9902-511 362	112	9902-553 163	112	9902-587 192	111	9906-015 082	115
9818-036 320	128	9902-515 001	116	9902-553 342	112	9902-587 193	111	9906-021 059	111
9818-036 322	128	9902-515 002	116	9902-553 362	112	9902-587 342	112	9906-021 183	111
9818-036 325	128	9902-515 003	116	9902-553 542	112	9902-587 343	112	9906-021 184	111
9818-036 327	128	9902-515 004	116	9902-553 562	112	9902-587 362	112	9906-022 081	111
9818-036 328	128	9902-515 025	116	9902-554 142	111	9902-587 363	112	9906-022 082	111
9818-036 330	128	9902-515 026	116	9902-554 162	111	9906-011 146	60	9906-022 085	111
9818-036 332	128	9902-515 027	116	9902-554 163	111	9906-011 147	60	9906-026 011	24
9818-036 335	128	9902-515 028	116	9902-554 192	111	9906-011 148	60	9906-026 012	24
9818-036 338	128	9902-515 040	116	9902-554 341	112	9906-011 149	60	9906-026 051	24
9818-036 341	128	9902-515 041	116	9902-554 361	112	9906-011 150	60	9906-026 053	24
9818-036 345	128	9902-515 042	116	9902-554 362	112	9906-011 151	60	9906-026 116	24
9818-036 348	128	9902-515 043	116	9902-554 441	111	9906-011 153	60	9906-026 117	24
9818-036 351	128	9902-515 050	116	9902-554 461	111	9906-011 154	60	9906-026 247	24
9818-036 354	128	9902-515 051	116	9902-565 142	112	9906-011 155	60	9906-026 248	24
9818-036 357	128	9902-515 052	116	9902-565 143	112	9906-011 446	60	9906-026 280	24
9818-036 360	128	9902-515 053	116	9902-565 162	112	9906-011 447	60	9906-026 281	24
9818-036 364	128	9902-515 056	116	9902-565 163	112	9906-011 448	60	9906-026 500	24
9828-036 308	128	9902-515 057	116	9902-565 342	112	9906-011 449	60	9906-026 501	24
9828-036 309	128	9902-515 058	116	9902-565 362	112	9906-011 450	60	9906-030 302	63
9828-036 310	128	9902-515 062	116	9902-565 542	112	9906-011 451	60	9906-030 304	63
9828-036 311	128	9902-515 063	116	9902-565 562	112	9906-011 453	60	9906-030 305	63
9828-036 312	128	9902-515 064	116	9902-566 142	111	9906-011 454	60	9906-030 308	63
9828-036 313	128	9902-515 065	116	9902-566 143	111	9906-011 455	60	9906-030 310	63
9828-036 316	128	9902-515 069	116	9902-566 162	111	9906-013 008	111	9906-030 311	63
9828-036 318	128	9902-515 079	116	9902-566 163	111	9906-013 009	111	9906-030 312	63
9828-036 320	128	9902-515 080	116	9902-566 192	111	9906-013 021	111	9906-030 314	63
9828-036 322	128	9902-515 081	116	9902-566 193	111	9906-013 057	111	9906-030 316	63
9828-036 325	128	9902-515 082	116	9902-566 341	112	9906-015 001	115	9906-030 317	63
9828-036 327	128	9902-522 142	111	9902-566 342	112	9906-015 002	115	9906-030 318	63
9828-036 328	128	9902-522 162	111	9902-566 361	112	9906-015 003	115	9906-030 326	64
9828-036 330	128	9902-522 163	111	9902-566 362	112	9906-015 004	115	9906-030 328	64
9828-036 332	128	9902-522 342	112	9902-566 363	112	9906-015 025	115	9906-030 329	64
9828-036 335	128	9902-522 362	112	9902-566 441	111	9906-015 026	115	9906-030 332	64
9828-036 338	128	9902-522 363	112	9902-566 461	111	9906-015 027	115	9906-030 334	64
9828-036 341	128	9902-532 142	111	9902-566 491	111	9906-015 028	115	9906-030 335	64
9828-036 345	128	9902-532 162	111	9902-575 142	112	9906-015 035	115	9906-030 338	64
9828-036 348	128	9902-532 163	111	9902-575 162	112	9906-015 036	115	9906-030 340	64
9828-036 351	128	9902-532 342	112	9902-575 163	112	9906-015 037	115	9906-030 341	64
9828-036 354	128	9902-532 343	112	9902-575 342	112	9906-015 038	115	9906-030 488	68
9828-036 357	128	9902-532 362	112	9902-576 142	111	9906-015 040	115	9906-030 489	68
9828-036 360	128	9902-532 363	112	9902-576 143	111	9906-015 041	115	9906-030 490	68
9828-036 364	128	9902-543 142	112	9902-576 162	111	9906-015 042	115	9906-030 492	68
9838-036 311	128	9902-543 162	112	9902-576 163	111	9906-015 043	115	9906-030 493	68
9838-036 313	128	9902-543 163	112	9902-576 192	111	9906-015 050	115	9906-030 494	68
9838-036 315	128	9902-543 362	112	9902-576 193	111	9906-015 051	115	9906-030 496	68

Order-No.	Page	Order-No.	Page	Order-No.	Page	Order-No.	Page
9906-030 497	68	9907-036 062	125	9946-015 058	115	L15452433E	105
9906-030 498	68	9907-036 063	125	9946-015 059	115	L15452448A	105
9906-030 500	68	9907-036 067	125	9962-515 056	116	L15452448E	105
9906-030 501	68	9907-036 072	125	9962-515 057	116	L50452008E	105
9906-030 502	68	9907-036 073	125	9962-515 058	116	L50901408A	105
9906-033 016	28	9907-036 082	125	9962-515 059	116	L50901408E	105
9906-033 021	28	9907-036 093	125	9962-515 062	116	L50901431A	105
9906-033 022	28	9907-036 139	125	9962-515 063	116	L50901431E	105
9906-033 030	28	9907-036 147	125	9962-515 064	116	L50902448A	105
9906-033 031	28	9907-036 151	125	9962-515 065	116	L50902448E	105
9906-033 125	28	9907-036 155	125	9966-015 063	115	L669002101	101
9906-033 126	28	9907-036 156	125	9966-015 064	115	L669002102	101
9907-035 000	124	9907-036 163	125	9966-015 065	115	L68013206J	105
9907-035 021	124	9907-036 164	125	L000000962	96	L68014192A	105
9907-035 023	124	9907-036 172	125	L000002066	98, 106	L68014192E	105
9907-035 031	124	9907-036 179	125	L000006338	96	L699740250	100
9907-035 032	124	9907-036 187	125	L000014507	105	L699740340	100
9907-035 041	124	9907-036 188	125	L000020899	98	L699940250	100
9907-035 042	124	9907-036 204	125	L000042624	105	L699940260	100
9907-035 051	124	9907-036 302	129	L000044060	98, 106	L699940320	100
9907-035 052	124	9907-036 303	129	L012021292	97	L699940340	100
9907-035 061	124	9907-036 304	129	L012021660	97	L779000175	102
9907-035 062	124	9907-036 305	129	L012021731	97	L779000433	102
9907-035 081	124	9907-036 306	129	L012022230	97	L779000462	102
9907-035 082	124	9907-036 307	129	L012022404	97	L779000466	102
9907-035 083	124	9907-036 308	129	L012022573	97	L779001385	102
9907-035 086	124	9907-036 309	129	L012022605	97	L779005333	102
9907-035 087	124	9907-036 310	129	L013010167	97	L779007012	102
9907-035 088	124	9907-036 311	129	L013030179	96	L779009510	102
9907-035 092	124	9907-036 312	129	L013030901	96	L779132001	102
9907-035 093	124	9907-036 313	129	L013030989	96	L779191001	102
9907-035 096	124	9907-036 314	129	L013033828	96	L779840010	102
9907-035 097	124	9907-036 315	129	L013300214	96	L779840130	102
9907-035 098	124	9907-036 316	129	L013300348	96	L779920160	102
9907-035 102	124	9907-036 317	129	L023060786	97	L779930401	102
9907-035 107	124	9907-036 318	129	L033440041	98	L800000008	98, 106
9907-035 117	124	9907-036 319	129	L033440201	98	L800000029	98, 106
9907-035 118	124	9907-036 320	129	L033440645	98	L800000046	98, 106
9907-035 127	124	9907-036 321	129	L043090792	96	L800000048	98, 106
9907-035 128	124	9907-036 322	129	L043310025	96	L800000055	98, 106
9907-035 137	124	9907-036 323	129	L043310047	96	L800000066	98, 106
9907-035 138	124	9907-036 478	129	L043310093	96	L800000084	98, 106
9907-035 181	124	9907-036 482	129	L043310189	96	L800000119	98, 106
9907-035 197	124	9907-036 483	129	L063330127	106	L800000126	98, 106
9907-035 205	124	9907-036 484	129	L063330132	106	L81545202E	105
9907-035 213	124	9907-036 486	129	L063330245	106	L81545231E	105
9907-035 221	124	9907-036 487	129	L063800137	105	L81545247E	105
9907-035 229	124	9907-036 488	129	L063800214	105	L911000436	95
9907-036 012	125	9907-036 489	129	L063800259	105	L940030842	95
9907-036 017	125	9907-036 490	129	L063800261	105	L960030577	104
9907-036 022	125	9907-036 491	129	L063800285	105		
9907-036 023	125	9908-608 132	28	L063800288	105		
9907-036 027	125	9908-608 152	28	L068011347	105		
9907-036 032	125	9916-015 026	115	L113010743	97		
9907-036 033	125	9916-015 041	115	L113010744	97		
9907-036 037	125	9916-015 051	115	L113010745	97		
9907-036 042	125	9916-015 057	115	L113010746	97		
9907-036 043	125	9916-015 069	115	L15451408A	105		
9907-036 047	125	9918-608 132	28	L15451408E	105		
9907-036 052	125	9918-608 152	28	L15451431A	105		
9907-036 053	125	9946-015 056	115	L15451431E	105		
9907-036 057	125	9946-015 057	115	L15452433A	105		



Additional products

OTHER CATALOGUES FOR DOWNLOAD

**IT'S THIS
EASY:**

The easiest and quickest way to get our catalogues is to download them from our website.

If you have a smartphone or tablet, you can also scan the QR code and get to the catalogue overview page.



<http://www.osborn.de/en-de/support/literature.html>



TERMS AND CONTACT

TERMS:

For our terms and conditions, please consult our website.

If you have a smartphone or tablet you can also scan the QR code and get to the overview page.



<http://www.osborn.de/en-de/company/all-terms-and-conditions.html>

Osborn International

Rm. 612, Tower R, Huiyuan Int. Apartment
No. 8 Beichen East Road,
Chaoyang District
Beijing, 100101
China
Tel.: +86 1084986167
Fax: +86 1064993009
cnsales@osborn.com

Osborn-Dronco

Newhouse Farm Industrial Estate
Chepstow NP16 6UD
Großbritannien
Tel.: +44 1291643200
Fax: +44 1291643298
sales@osborn.co.uk

Osborn International AB

Huskvarnavägen 105
56123 Huskvarna
Schweden
Tel.: +46 36389200
Fax: +46 36133190
info@osborn.se

Osborn International GmbH

Ringstrasse 10
35099 Burgwald
Deutschland
Tel.: +49 64515880
Fax: +49 6451588206
info@osborn.de

Osborn Lippert (India) Pvt. Ltd.

Plot No. E-66, MIDC Waluj
Aurangabad - 431 136
Indien
Tel.: +91 2402556538
Fax: +91 2402552530
sales@osborn-lippert.co.in

Osborn Singapore Pte Ltd

206 Tuas South Avenue 2
West Point Bizhub
Singapore 637208
Singapur
Tel.: +65 6863 0318
Fax: +65 6863 4318
sales@osborn.com.sg

Osborn International GmbH

Betriebsstätte Haan
Rudolf-Harbig-Weg 10
42781 Haan
Deutschland
Tel.: +49 212993070
Fax: +49-2129930723
polishing@osborn.de

JacksonLea de Mexico

Emilio Cárdenas No. 211
Centro Industrial Tlalnepantla
Tlalnepantla Edo. México, 54030
Mexico
Tel.: +52 5555659255

Osborn - Unipol, S.L.

C/ Ronda Norte, 320
(Polígono Industrial) - Apartado 169
46470 Catarroja (Valencia)
Spanien
Tel.: +34 961325876
Fax: +34 961324602
ventas@osborn-unipol.es

DRONCO GmbH

Wiesenmühle 1
95632 Wunsiedel
Deutschland
Tel.: +49 92326090
Fax: +49 9232609159
info@dronco.com

Osborn Unipol Lda

Rua de Paredelhas
4805-062 Brito-Guimarães
Portugal
Tel.: +351 253479550
Fax: +351 253576629
osborn-unipol@osborn-unipol.pt

Osborn

2350 Salisbury Road North
Richmond, IN 47374
USA
Tel.: +1 (765) 965-5333
Fax: +1 (765) 935-0120
brushes@osborn.com

Osborn Unipol SAS

Parc Mail Bâtiment Orion
24B avenue de la Demi-Lune
CS 80006 - 95735 ROISSY CH. DE GAULLE CEDEX
Frankreich
Tel.: +33 134450600
Fax: +33 139936711
contact@osborn-unipol.fr

Osborn International SRL

Bd. Bucovina, Nr. 151
725300 Gura Humorului, jud. Suceava
Rumänien
Tel.: +40 230234212
Fax: +40 230531785
sales@osborn.ro

General references:

The tools illustrated in this catalogue, the information given on quantities, appearance, properties and dimensions correspond to the data available at the time of printing. We are constantly improving our products, which are thus subject to alterations. In case of prices listed in this catalogue, all previous price lists will lose their validity with appearance of this catalogue.

General Information:

The tools shown in this catalogue, information on scope of delivery, appearance, performance and specifications have been carefully collated and are correct at the time of going in to print. We are constantly developing our products, therefore the parts and prices shown can be subject to change.

Prices indicated in the new catalogue are now applicable and previously published prices lose their validity. All prices are per piece in Euros, excluding VAT, packaging, freight, carriage and insurance. Our general terms and conditions apply to all orders.

Cutting | Grinding | Sanding

DRONCO GmbH

Wiesenmühle 1
95632 Wunsiedel/Germany

Tel.: +49 (0) 92 32/609-0
Fax: +49 (0) 92 32/609-159
info@dronco.com
www.dronco.com

Osborn Sells Solutions

The Global Leader in
Surface Treatment Solutions and Finishing Tools

Osborn International GmbH

Ringstraße 10
35099 Burgwald/Germany

Tel.: +49 (64 51) 5 88-0
Fax: +49 (64 51) 5 88-206
info@osborn.de
www.osborn.de